

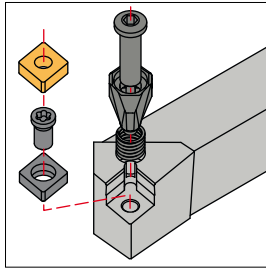

TOOLHOLDERS KLEMMHALTER

Clamping systems Klemmsysteme	A62
Code system (ISO) Kodifizierung (ISO)	A63
Applications index Anwendungen	A64-67
Dimple lock toolholders Klemmhalter mit Dimple Lock-Klemmung	A68-79
Wedge clamp toolholders / Double lock toolholders Klemmhalter mit Pratzen-Klemmung / Klemmhalter mit Doppel-Klemmung	A80-93
Lever lock toolholders Klemmhalter mit Kniehebel-Klemmung	A94-113
Top clamp toolholders Klemmhalter mit oberer Klemmung	A114-127
Center screw toolholders Klemmhalter mit Zentralschrauben-Klemmung	A128-165
Cutting data Schnittdaten	A166-167



(D) Dimple lock

The "D" clamping system avoids insert movement during high feed or heavily interrupted machining, due to its accurate indexing that holds the insert securely clamped.

Das "D"-Klemmsystem vermeidet die Bewegung der Wendeschneidplatte bei hohem Vorschub oder bei stark unterbrochener Bearbeitung dank der genauen Positionierung, die die Wendeschneidplatte sicher befestigt.

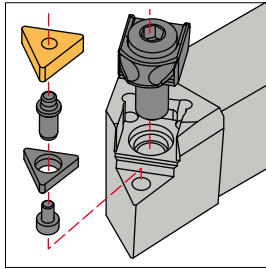
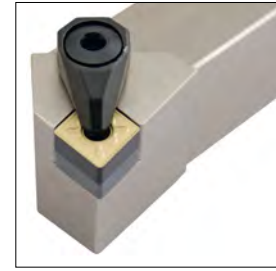

**(M) Wedge clamp
(M) Prätzen-Klemmung**

Negative inserts require good clamping force for heavy duty work, for this purpose we have designed our "M" system, one of the strongest and safest available.

Die negativen Wendeplatten für sehr schwere Zerspanungsarbeiten benötigen eine gute Klemmung, dafür bieten wir unser "M" Klemmsystem, das eines der stärksten und sichersten ist.

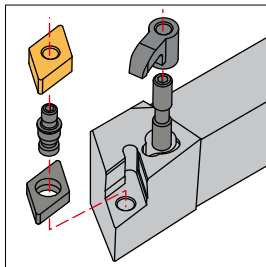
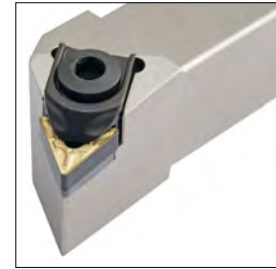

**(M-K) Double lock
(M-K) Doppel-Klemmung**

The double lock system offers good rigidity in negative inserts clamping. It is the first choice for center hole negative ceramic and cermet inserts.

Das doppelte Klemmsystem bietet eine gute Unbeweglichkeit bei der Klemmung von negativen Wendeschneidplatten. Es ist die erste Wahl für negative Keramik-Wendeschneidplatten mit zentralem Loch und auch für Cermet-Wendeschneidplatten.

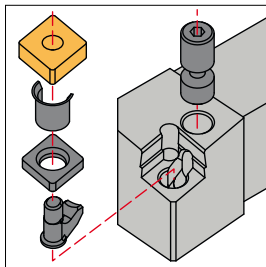

**(P) Lever lock
(P) Kniehebel-Klemmung**

The classic lever lock system allows a wide range of applications. It is the first choice for general purpose turning toolholders.

Das klassische Hebel-System erlaubt eine breite Reihe von Anwendungen. Es ist die erste Wahl für allgemeine Drehoperationen.

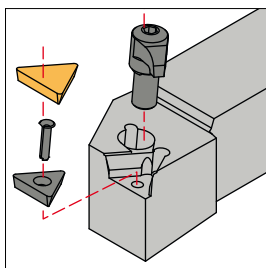

**(C) Top clamp
(C) Obere Klemmung**

The classic positive insert clamping system is designed to hold flat positive inserts, both with additional or sintered chipbreaker.

Dieses klassische Klemmsystem von positiven Wendeplatten erlaubt die Verwendung von allen Wendeplatten dieses Typs, in üblicher Sinterausführung sowohl als auch mit Spanbrecher.

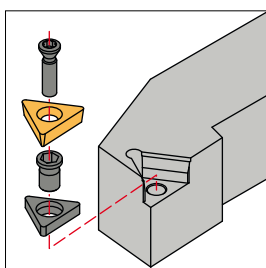

**(S) Center screw
(S) Zentralschrauben-Klemmung**

Since the advent of the TORX screw it has been possible to hold with complete safety positive inserts with center hole. Our range covers all the screw fixing permutations.

Seit der Einführung der Torx-Schraube ist es möglich, die positiven Wendeschneidplatten mit zentralem Loch zu klemmen. Unser Programm bietet alle Klemmmöglichkeiten mit Schraube.



Code system / Kodifizierung (ISO)

P	C	L	N	R	25	25	M	12
1	2	3	4	5	6	7	8	9

1 Clamping method of insert
Klemmsystem

2 Insert shape
Wendeschneidplatten-Form

C	D	E	K
R	S	T	V
W			

4 Clearance angle of insert
Wendeschneidplatten-Freiwinkel

5 Hand
Bearbeitungsrichtung

6 Shank height, mm
Schafthöhe, mm.

7 Shank width, mm
Schaftbreite, mm.

3 Holder style
Einstellwinkel

A	B	C
D	E	F
G	H	J
K	L	M
N	Q	R
S	T	V
X	Z	

8 Tool length, mm
Werkzeuglänge, mm.

D	60	P	170
E	70	R	200
F	80	S	250
H	100	T	300
K	125	U	350
L	140	V	400
M	150	X	Special Sonder

9 Cutting edge length, mm
Schneidkantenlänge, mm.

NEGATIVE TOOLHOLDERS / NEGATIVE KLEMMHALTER

Dimple lock toolholders Klemmhalter mit Dimple Lock-Klemmung

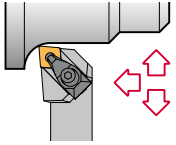
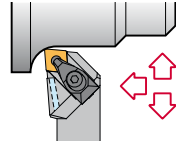
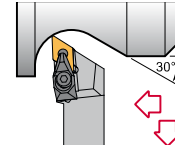
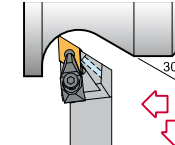
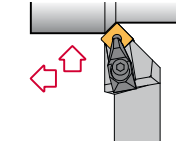
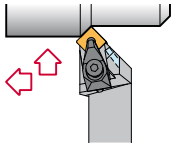
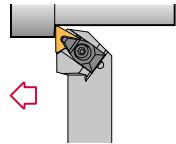
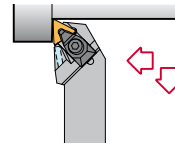
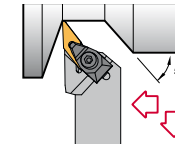
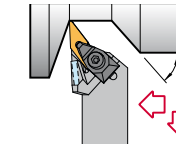
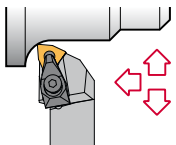
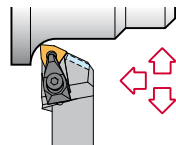
<p>DCLN 95°-N</p>  <p>Page Seite A68 CN.. 1204.. CN.. 1906..</p>	<p>DCLN 95°-A</p>  <p>Page Seite A69 CN.. 1204.. CN.. 1906..</p>	<p>DDJN 93°-N</p>  <p>Page Seite A70 DN.. 1104.. DN.. 1506..</p>	<p>DDJN 93°-A</p>  <p>Page Seite A71 DN.. 1104.. DN.. 1506..</p>	<p>DSSN 45°-N</p>  <p>Page Seite A72 SNM.. 1204.. SNM.. 1906..</p>
<p>DSSN 45°-A</p>  <p>Page Seite A73 SNM.. 1204.. SNM.. 1906..</p>	<p>DTGN 90°-N</p>  <p>Page Seite A74 TNM.. 1604.. TNM.. 2204..</p>	<p>DTJN 93°-A</p>  <p>Page Seite A75 TNM.. 1604..</p>	<p>DVJN 93°-N</p>  <p>Page Seite A76 VN.. 1604..</p>	<p>DVJN 93°-A</p>  <p>Page Seite A77 VN.. 1604..</p>
<p>DWLN 95°-N</p>  <p>Page Seite A78 WNMG 0804..</p>	<p>DWLN 95°-A</p>  <p>Page Seite A79 WNMG 0604.. WNMG 0804..</p>			

Wedge clamp / Double lock toolholders Klemmhalter mit Pratzen- und Doppel-Klemmung

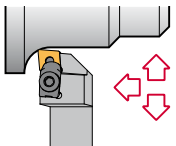
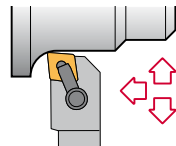
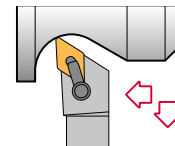
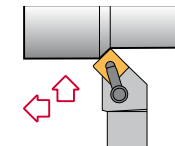
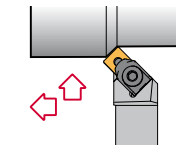
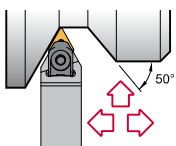
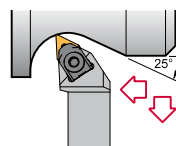
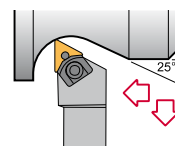
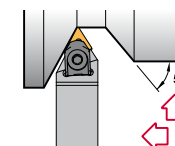
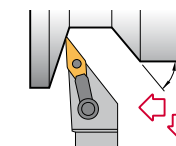
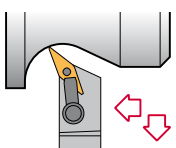
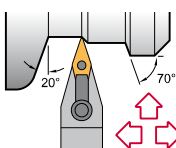
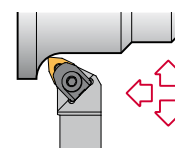
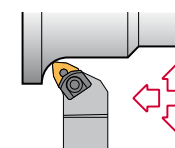
<p>MCLN 95°</p>  <p>Page Seite A80 CN.. 1204.. CN.. 1906..</p>	<p>MCLN-K 95°</p>  <p>Page Seite A81 CN.. 1204.. CN.. 1906..</p>	<p>MDJN-K 93°</p>  <p>Page Seite A82 DN.. 1506..</p>	<p>MSSN-K 45°</p>  <p>Page Seite A83 SNM.. 1204..</p>	<p>MSSN 45°</p>  <p>Page Seite A84 SNM.. 1204.. SNM.. 1906..</p>
<p>MTEN 60°</p>  <p>Page Seite A85 TNM.. 1604.. TNM.. 2204..</p>	<p>MTJN 93°</p>  <p>Page Seite A86 TNM.. 1604.. TNM.. 2204..</p>	<p>MTJN-K 93°</p>  <p>Page Seite A87 TNM.. 1604.. TNM.. 2204..</p>	<p>MTNN 63°</p>  <p>Page Seite A88 TNM.. 1604.. TNM.. 2204..</p>	<p>MVJN-K 93°</p>  <p>Page Seite A89 VN.. 1604..</p>
<p>MVQN-K 117°30'</p>  <p>Page Seite A90 VN.. 1604..</p>	<p>MVVN-K 72°30'</p>  <p>Page Seite A91 VN.. 1604..</p>	<p>MWLN 95°</p>  <p>Page Seite A92 WNM.. 0604.. WNM.. 0804..</p>	<p>MWLN-K 95°</p>  <p>Page Seite A93 WNM.. 0804..</p>	



NEGATIVE TOOLHOLDERS / NEGATIVE KLEMMHALTER

Lever lock toolholders Klemmhalter mit Kniehebel-Klemmung

<p>PCBN 75°</p> <p>Page Seite A94</p> <p>CN.. 1204.. CN.. 1606.. CN.. 1906.. CN.. 2509..</p>	<p>PCFN 90°</p> <p>Page Seite A95</p> <p>CN.. 1204.. CN.. 1606.. CN.. 1906..</p>	<p>PCKN 75°</p> <p>Page Seite A96</p> <p>CN.. 1204.. CN.. 1906.. CN.. 2509..</p>	<p>PCLN 95°</p> <p>Page Seite A97</p> <p>CN.. 0903.. .. CN.. 2509..</p>	<p>PCMN 50°</p> <p>Page Seite A98</p> <p>CN.. 1204.. CN.. 1906.. CN.. 2509..</p>
<p>PCSN 45°</p> <p>Page Seite A99</p> <p>CN.. 1204.. CN.. 1606.. CN.. 1906..</p>	<p>PDJN 93°</p> <p>Page Seite A100</p> <p>DN.. 1104.. DN.. 1504.. DN.. 1506..</p>	<p>PDNN 63°</p> <p>Page Seite A101</p> <p>DN.. 1504.. DN.. 1506..</p>	<p>PRDC</p> <p>Page Seite A102</p> <p>RC.. 1003.. .. RC.. 3209..</p>	<p>PRSC</p> <p>Page Seite A103</p> <p>RC.. 1003.. .. RC.. 3209..</p>
<p>PRSN</p> <p>Page Seite A104</p> <p>RNMG 0903.. .. RNMG 2509..</p>	<p>PSBN 75°</p> <p>Page Seite A105</p> <p>SNM.. 0903.. SNM.. 2507..</p>	<p>PSDN 45°</p> <p>Page Seite A106</p> <p>SNM.. 0903.. SNM.. 2507..</p>	<p>PSKN 75°</p> <p>Page Seite A107</p> <p>SNM.. 0903.. .. SNM.. 2507..</p>	<p>PSSN 45°</p> <p>Page Seite A108</p> <p>SNM.. 0903.. SNM.. 2507..</p>
<p>PTDN 45°</p> <p>Page Seite A109</p> <p>TNM.. 2204..</p>	<p>PTFN 90°</p> <p>Page Seite A110</p> <p>TNM.. 1604.. .. TNM.. 2706..</p>	<p>PTGN 90°</p> <p>Page Seite A111</p> <p>TNM.. 1604.. .. TNM.. 3307..</p>	<p>PTTN 60°</p> <p>Page Seite A112</p> <p>TNM.. 1604.. TNM.. 2204..</p>	<p>PWLN 95°</p> <p>Page Seite A113</p> <p>WNM.. 0604.. WNM.. 0804..</p>

POSITIVE TOOLHOLDERS / POSITIVE KLEMMHALTER

Top clamp toolholders Klemmhalter mit oberer Klemmung

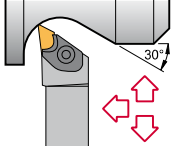
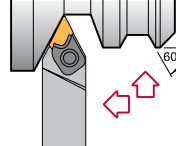
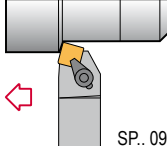
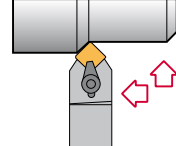
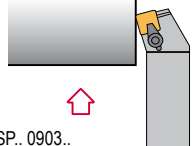
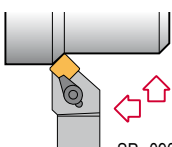
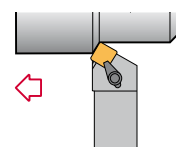
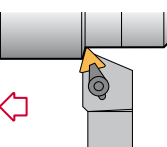
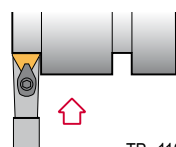
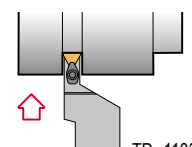
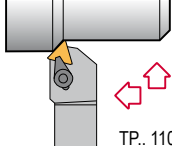
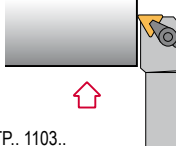
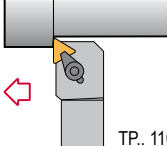
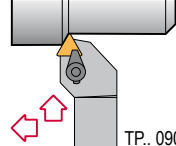
<p>CKJN 93°</p>  <p>Page Seite A114</p> <p>KNUX 1604..</p>	<p>CKNN 63°</p>  <p>Page Seite A115</p> <p>KNUX 1604..</p>	<p>CSBP 75°</p>  <p>Page Seite A116</p> <p>SP.. 0903.. SP.. 1203.. SP.. 1904..</p>	<p>CSDP 45°</p>  <p>Page Seite A117</p> <p>SP.. 0903.. SP.. 1203..</p>	<p>CSKP 75°</p>  <p>Page Seite A118</p> <p>SP.. 0903.. SP.. 1203.. SP.. 1904..</p>
<p>CSSP 45°</p>  <p>Page Seite A119</p> <p>SP.. 0903.. SP.. 1203.. SP.. 1904..</p>	<p>CSTP 60°</p>  <p>Page Seite A120</p> <p>SP.. 0903.. SP.. 1203..</p>	<p>CTBP 75°</p>  <p>Page Seite A121</p> <p>TP.. 1103.. TP.. 1603..</p>	<p>CTCPN 90°</p>  <p>Page Seite A122</p> <p>TP.. 1103.. TP.. 1603.. TP.. 2204..</p>	<p>CTCP 90°</p>  <p>Page Seite A123</p> <p>TP.. 1103.. TP.. 1603.. TP.. 2204..</p>
<p>CTDP 45°</p>  <p>Page Seite A124</p> <p>TP.. 1103.. TP.. 1603.. TP.. 2204..</p>	<p>CTFP 90°</p>  <p>Page Seite A125</p> <p>TP.. 1103.. TP.. 1603.. TP.. 2204..</p>	<p>CTGP 90°</p>  <p>Page Seite A126</p> <p>TP.. 1103.. TP.. 1603.. TP.. 2204..</p>	<p>CTTP 60°</p>  <p>Page Seite A127</p> <p>TP.. 0902.. TP.. 1103.. TP.. 1603..</p>	

Center screw toolholders Klemmhalter mit Zentralschrauben-Klemmung

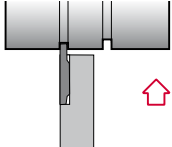
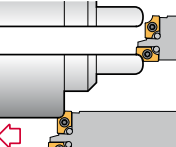
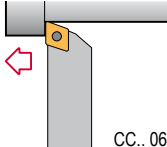
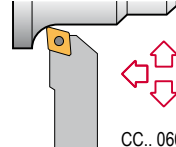
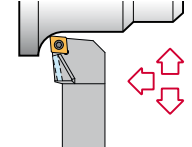
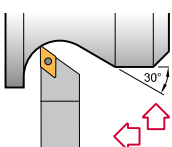
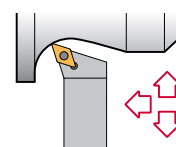
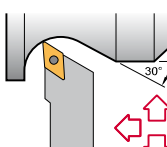
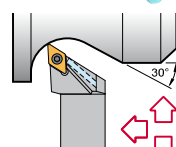
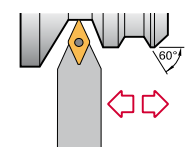
<p>STHE</p>  <p>Page Seite A128</p> <p>GI..</p>	<p>SAGD 90°</p>  <p>Page Seite A129</p> <p>ADMT.. 1503..</p>	<p>SCAC 90°</p>  <p>Page Seite A130-131</p> <p>CC.. 0602.. CC.. 09T3.. CC.. 1204..</p>	<p>SCLC 95°</p>  <p>Page Seite A132,134</p> <p>CC.. 0602.. CC.. 09T3.. CC.. 1204..</p>	<p>SCLC 95°-A</p>  <p>Page Seite A133</p> <p>CC.. 09T3..</p>
<p>SDAC 90°</p>  <p>Page Seite A135</p> <p>DC.. 0702.. DC.. 11T3..</p>	<p>SDHC 107,5°</p>  <p>Page Seite A136</p> <p>DC.. 11T3..</p>	<p>SDJC 93°</p>  <p>Page Seite A137,139</p> <p>DC.. 0702.. DC.. 11T3..</p>	<p>SDJC 93°-A</p>  <p>Page Seite A138</p> <p>DC.. 11T3..</p>	<p>SDNC 62° 30'</p>  <p>Page Seite A140-141</p> <p>DC.. 0702.. DC.. 11T3..</p>



POSITIVE TOOLHOLDERS / POSITIVE KLEMMHALTER

Center screw toolholders Klemmhalter mit Zentralschrauben-Klemmung

<p>SRDC</p> <p>RC.. 0602.. Page .. Seite A142 RC.. 1204..</p>	<p>SSBC 75°</p> <p>Page .. Seite A143 SC.. 09T3.. SC.. 1204..</p>	<p>SSDC 45°</p> <p>Page .. Seite A144 SC.. 09T3.. SC.. 1204..</p>	<p>SSSC 45°</p> <p>Page .. Seite A145 SC.. 09T3.. SC.. 1204..</p>	<p>STAC 90°</p> <p>TC.. 0902.. Page .. Seite A146 TC.. 1102.. TC.. 16T3..</p>
<p>STDC 45°</p> <p>TC.. 0902.. Page .. Seite A147 TC.. 1102.. TC.. 16T3..</p>	<p>STFC 90°</p> <p>TC.. 0902.. Page .. Seite A148 TC.. 1102.. TC.. 16T3..</p>	<p>STGC 90°</p> <p>Page .. Seite A149 TC.. 0902.. TC.. 1102.. TC.. 16T3..</p>	<p>STJC 93°</p> <p>Page .. Seite A150-151 TC.. 0902.. TC.. 1102.. TC.. 16T3..</p>	<p>STTC 60°</p> <p>Page .. Seite A152 TC.. 0902.. TC.. 1102.. TC.. 16T3..</p>
<p>STXC 10°-80°</p> <p>Page .. Seite A153 ADMT 1503.. TCMT 16T3..</p>	<p>SVAC 90°</p> <p>Page .. Seite A154 VC.. 1103.. VC.. 1604..</p>	<p>SVHC 107°30'</p> <p>Page .. Seite A155 VC.. 1604.. VC.. 2205..</p>	<p>SVJB 93°</p> <p>Page .. Seite A156 VBMT 1604..</p>	<p>SVJC 93°</p> <p>Page .. Seite A157,159 VC.. 1103.. VC.. 1604..</p>
<p>SVJC 93°-A</p> <p>Page .. Seite A158 VC.. 1103.. VC.. 1604..</p>	<p>SVLC 95°</p> <p>Page .. Seite A160 VCMT 1303..</p>	<p>SVVB 72°30'</p> <p>Page .. Seite A161 VBMT 1604..</p>	<p>SVVC 72°30'</p> <p>Page .. Seite A162-163 VC.. 1103.. VC.. 1604..</p>	<p>SVXC 113°</p> <p>Page .. Seite A164 VCMT 1303..</p>
<p>SVZC 100°</p> <p>Page .. Seite A165 VC.. 1604..</p>				



Characteristics:

Multipurpose toolholder equipped with rhombic negative double-sided insert (angle 80°).
For low powered machines and small pieces choose toolholder Ref. SCLC (Page: A132).

Axial -6,5°
Radial -6,5°

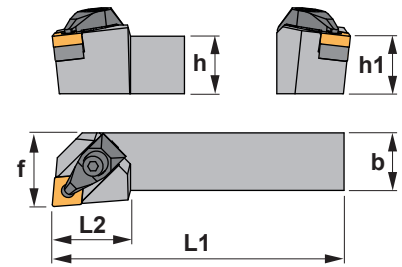

Eigenschaften:

Multifunktions-Werkzeuge mit doppelseitigen rhombischen negativen Wendeschneidplatten (Winkel 80°).
Für Niederleistungsmaschinen und kleine Werkstücke, wählen Sie Klemmhalter SCLC (Seite: A132).

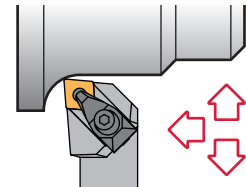

DCLN 95°-N

Reference Bezeichnung	h=h1	b	L1	L2	f	Insert size Wendeschneidplatte	kg
DCLN R/L 2020 K12-N	20	20	125	34	25	CN.. 1204..	0,400
DCLN R/L 2525 M12-N	25	25	150	34	32	CN.. 1204..	0,750
DCLN R/L 3232 P12-N	32	32	170	34	40	CN.. 1204..	1,300
DCLN R/L 2525 M16-N	25	25	150	42	32	CN.. 1606..	0,750
DCLN R/L 3232 P16-N	32	32	170	42	40	CN.. 1606..	1,300
DCLN R/L 3232 P19-N	32	32	170	42	40	CN.. 1906..	1,300
DCLN R/L 4040 S19-N	40	40	250	45	50	CN.. 1906..	3,050

Reference Bezeichnung							Nm
DCLN R/L 2020 K12-N	ICSN-442	1766	2712	1696	4295	5004	3.5
DCLN R/L 2525 M12-N	ICSN-442	1766	2712	1696	4295	5004	3.5
DCLN R/L 3232 P12-N	ICSN-442	1766	2712	1696	4295	5004	3.5
DCLN R/L 2525 M16-N	ICSN-533	1768	2716	1696	4295	5004	3.5
DCLN R/L 3232 P16-N	ICSN-533	1768	2716	1696	4295	5004	3.5
DCLN R/L 3232 P19-N	ICSN-633	1770	2719	1696	4295	5004	3.5
DCLN R/L 4040 S19-N	ICSN-633	1770	2719	1696	4295	5004	3.5

CN..

80° rhombic negative inserts. A32-34
80° rhombische negative WSP.

Reference / Bez.	l	s	d
CN.. 1204..	12,90	4,76	12,70
CN.. 1606..	16,10	6,35	15,88
CN.. 1906..	19,30	6,35	19,05

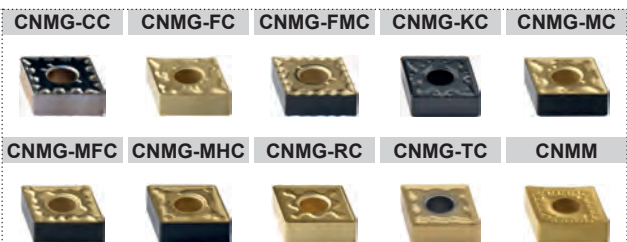
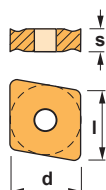

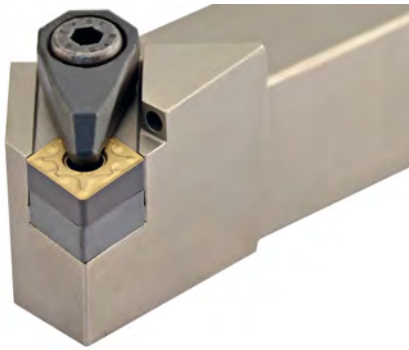

Characteristics:

Multipurpose toolholder equipped with rhombic negative double-sided insert (angle 80°).
For low powered machines and small pieces choose toolholder Ref. SCLC-A (Page: A133).

Axial -6,5°
Radial -6,5°

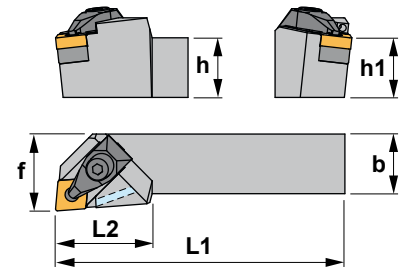

Eigenschaften:

Multifunktions-Werkzeuge mit doppelseitigen rhombischen negativen Wendeschneiplatten (Winkel 80°).
Für Niederleistungsmaschinen und kleine Werkstücke, wählen Sie Klemmhalter SCLC-A (Seite: A133).

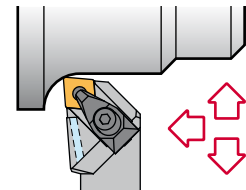

DCLN 95°-A

Reference Bezeichnung	h=h1	b	L1	L2	f	Insert size Wendeschneidplatte	
DCLN R/L 2020 K12-A	20	20	125	34	25	CN.. 1204..	0,400
DCLN R/L 2525 M12-A	25	25	150	34	32	CN.. 1204..	0,750
DCLN R/L 3232 P12-A	32	32	170	34	40	CN.. 1204..	1,300
DCLN R/L 3232 P16-A	32	32	170	42	40	CN.. 1606..	1,250

Reference Bezeichnung										Nm
DCLN R/L 2020 K12-A	ICSN-442	1766	2712	1696	4295	5004	1506	1592	1598	3.5
DCLN R/L 2525 M12-A	ICSN-442	1766	2712	1696	4295	5004	1506	1592	1598	3.5
DCLN R/L 3232 P12-A	ICSN-442	1766	2712	1696	4295	5004	-	1592	-	3.5
DCLN R/L 3232 P16-A	ICSN-533	1768	2716	1696	4295	5004	-	1592	-	3.5

CN..

80° rhombic negative inserts. A32-34
80° rhombische negative WSP.

Reference / Bez.	l	s	d
CN.. 1204..	12,90	4,76	12,70
CN.. 1606..	16,10	6,35	15,88

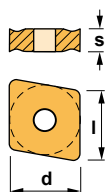



Characteristics:

Turning and profiling toolholder equipped with rhombic negative double-sided insert (angle 55°).

For low powered machines and small pieces choose toolholder Ref. SDJC (Page: A137).

Axial 6,25°
Radial -6,75°

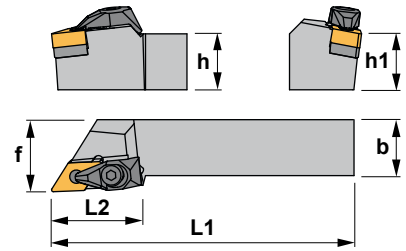

Eigenschaften:





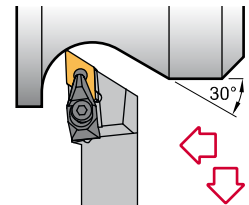

Klemmhalter zum Drehen und Kopierdrehen mit doppelseitigen rhombischen negativen Wendeschneiplatten (Winkel 55°).

Für Niederleistungsmaschinen und kleine Werkstücke, wählen Sie Klemmhalter SDJC (Seite: A137).



DDJN 93°-N

Reference Bezeichnung	h=h1	b	L1	L2	f	Insert size Wendeschneidplatte	KG
DDJN R/L 2020 K11-N	20	20	125	34	25	DN.. 1104..	0,400
DDJN R/L 2525 M11-N	25	25	150	34	32	DN.. 1104..	0,740
DDJN R/L 2020 K15-N	20	20	125	42	25	DN.. 1506..	0,400
DDJN R/L 2525 M15-N	25	25	150	42	32	DN.. 1506..	0,750
DDJN R/L 3232 P15-N	32	32	170	42	40	DN.. 1506..	1,300

Reference Bezeichnung							Nm
DDJN R/L 2020 K11-N	IDSN-322	1764	2708	1695	4294	5004	3.5
DDJN R/L 2525 M11-N	IDSN-322	1764	2708	1695	4294	5004	3.5
DDJN R/L 2020 K15-N	IDSN-432	1766	2712	1696	4295	5004	3.5
DDJN R/L 2525 M15-N	IDSN-432	1766	2712	1696	4295	5004	3.5
DDJN R/L 3232 P15-N	IDSN-432	1766	2712	1696	4295	5004	3.5

DN.. 55° rhombic negative inserts.  A36-37
55° rhombische negative Wendeschneidplatten.

Reference / Bez.	l	s	d
DN.. 1104..	11,60	4,76	9,52
DN.. 1506..	15,50	6,35	12,70

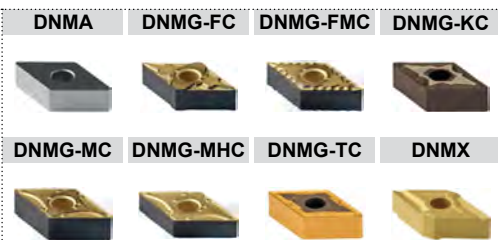
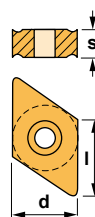



Characteristics:

Turning and profiling toolholder equipped with rhombic negative double-sided insert (angle 55°).

For low powered machines and small pieces choose toolholder Ref. SDJC-A (Page: A138).

Axial 6,25°
Radial -6,75°

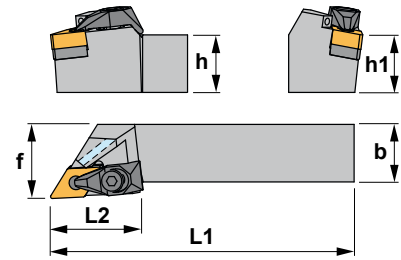

Eigenschaften:

Klemmhalter zum Drehen und Kopierdrehen mit doppelseitigen rhombischen negativen Wendeschneiplatten (Winkel 55°).

Für Niederleistungsmaschinen und kleine Werkstücke, wählen Sie Klemmhalter SDJC-A (Seite: A138).

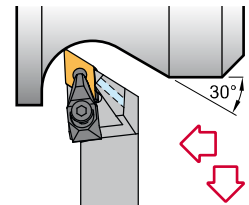

DDJN 93°-A

Reference Bezeichnung	h=h1	b	L1	L2	f	Insert size Wendeschneidplatte	KG
DDJN R/L 2020 K11-A	20	20	125	34	25	DN.. 1104..	0,400
DDJN R/L 2020 K15-A	20	20	125	42	25	DN.. 1506..	0,400
DDJN R/L 2525 M15-A	25	25	150	42	32	DN.. 1506..	0,750
DDJN R/L 3232 P15-A	32	32	170	42	40	DN.. 1506..	1,300

Reference Bezeichnung										Nm
DDJN R/L 2020 K11-A	IDSN-322	1764	2708	1695	4294	5004	1506	1592	1598	3.5
DDJN R/L 2020 K15-A	IDSN-432	1766	2712	1696	4295	5004	1506	1592	1598	3.5
DDJN R/L 2525 M15-A	IDSN-432	1766	2712	1696	4295	5004	1506	1592	1598	3.5
DDJN R/L 3232 P15-A	IDSN-432	1766	2712	1696	4295	5004	-	1592	-	3.5

DN.. 55° rhombic negative inserts. A36-37
55° rhombische negative Wendeschneidplatten.

Reference / Bez.	l	s	d
DN.. 1104..	11,60	4,76	9,52
DN.. 1506..	15,50	6,35	12,70

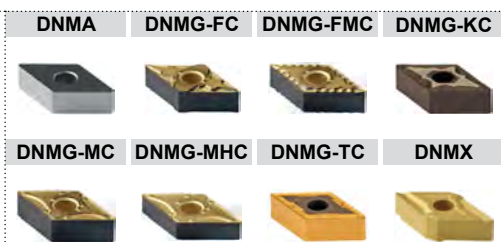
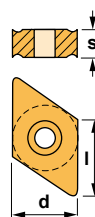



Characteristics:

Toolholder for external turning and chamfering applications equipped with square negative inserts.

For low powered machines and small pieces choose toolholder Ref. CSSP (Page: A119) or SSSC (Page: A145).

Axial -5,75°
Radial -5,75°

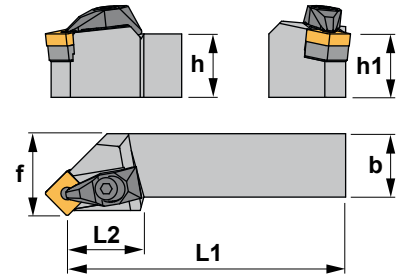

Eigenschaften:

Klemmhalter zum Außendrehen und Abschrägen mit vierkantigen negativen Wendeschneidplatten.

Für Niederleistungsmaschinen und kleine Werkstücke, wählen Sie Klemmhalter CSSP (Seite: A119) oder SSSC (Seite: A145).

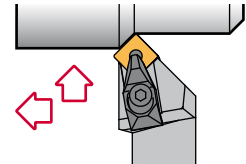

DSSN 45°-N

Reference Bezeichnung	h=h1	b	L1	L2	f	Insert size Wendeschneidplatte	kg
DSSNR/L2020K12-N	20	20	125	28	25	SNM.. 1204..	0,400
DSSNR/L2525M12-N	25	25	150	28	32	SNM.. 1204..	0,750
DSSNR/L3225P12-N	32	25	170	42	32	SNM.. 1204..	1,140
DSSNR/L2525M15-N	25	25	150	42	32	SNM.. 1506..	0,820
DSSNR/L3232P15-N	32	32	170	45	40	SNM.. 1506..	1,440
DSSNR/L3232P19-N	32	32	170	45	40	SNM.. 1906..	1,300
DSSNR/L4040S19-N	40	40	250	45	50	SNM.. 1906..	3,100

Reference Bezeichnung							Nm
DSSNR/L2020K12-N	ISSN-442	1766	2712	1696	4295	5004	3.5
DSSNR/L2525M12-N	ISSN-442	1766	2712	1696	4295	5004	3.5
DSSNR/L3225P12-N	ISSN-442	1766	2712	1696	4295	5004	3.5
DSSNR/L2525M15-N	ISSN-533	1768	2716	1696	4295	5004	3.5
DSSNR/L3232P15-N	ISSN-533	1768	2716	1696	4295	5004	3.5
DSSNR/L3232P19-N	ISSN-633	1770	2719	1696	4295	5004	3.5
DSSNR/L4040S19-N	ISSN-633	1770	2719	1696	4295	5004	3.5

SNM..

Square negative inserts. A41-42
Vierkantige negative Wendeschneidplatten.

Reference / Bez.	l	s	d
SNM.. 1204..	12,70	4,76	12,70
SNM.. 1506..	15,88	6,35	15,88
SNM.. 1906..	19,05	6,35	19,05

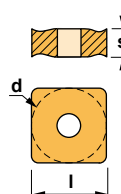

SNMG-FMC



SNMG-KC



SNMG-MHC



SNMG-RC



SNMG-TC



SNMM



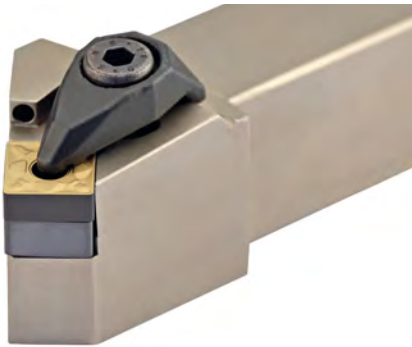

Characteristics:

Toolholder for external turning and chamfering applications equipped with square negative inserts.

For low powered machines and small pieces choose toolholder Ref. CSSP (Page: A119) or SSSC (Page: A145).

Axial -5,75°
Radial -5,75°

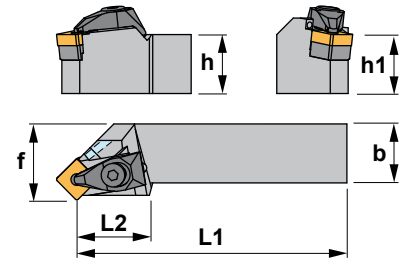

Eigenschaften:

Klemmhalter zum Außendrehen und Abschrägen mit vierkantigen negativen Wendeschneidplatten.

Für Niederleistungsmaschinen und kleine Werkstücke, wählen Sie Klemmhalter CSSP (Seite: A119) oder SSSC (Seite: A145).

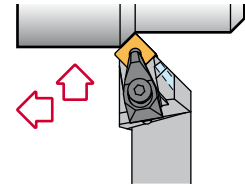

DSSN 45°-A

Reference Bezeichnung	h=h1	b	L1	L2	f	Insert size Wendeschneidplatte	
DSSN R/L 2020 K12-A	20	20	125	28	25	SNM.. 1204..	0,400
DSSN R/L 2525 M12-A	25	25	150	28	32	SNM.. 1204..	0,750
DSSN R/L 3232 P19-A	32	32	170	38	40	SNM.. 1906..	1,300

Reference Bezeichnung										Nm
DSSN R/L 2020 K12-A	ISSN-442	1766	2712	1696	4295	5004	1506	1592	1598	3.5
DSSN R/L 2525 M12-A	ISSN-442	1766	2712	1696	4295	5004	1506	1592	1598	3.5
DSSN R/L 3232 P19-A	ISSN-633	1770	2719	1696	4295	5004	-	1592	-	3.5

SNM.. <small>Square negative inserts. Vierkantige negative Wendeschneidplatten. A41-42</small>							SNMG-FMC	SNMG-KC	SNMG-MHC
Reference / Bez.	l	s	d				SNMG-RC	SNMG-TC	SNMM
SNM.. 1204..	12,70	4,76	12,70						
SNM.. 1906..	19,05	6,35	19,05						



Characteristics:

Toolholder for external turning applications equipped with triangular negative inserts. For low powered machines and small pieces choose toolholder Ref. CTGP (Page: A126) or STGC (Page: A149).

Axial -6°
Radial -6°

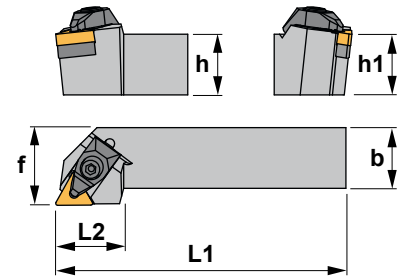

Eigenschaften:

Klemmhalter zum Außendrehen mit dreikantigen negativen Wendschneidplatten. Für Niederleistungsmaschinen und kleine Werkstücke, wählen Sie Klemmhalter CTGP (Seite: A126) oder STGC (Seite: A149).

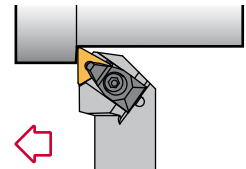

DTGN 90°-N

Reference Bezeichnung	h=h1	b	L1	L2	f	Insert size Wendschneidplatte	Kg
DTGN R/L 2020 K16-N	20	20	125	28	25	TNM.. 1604..	0,400
DTGN R/L 2525 M16-N	25	25	150	28	32	TNM.. 1604..	0,750
DTGN R/L 2525 M22-N	25	25	150	34	32	TNM.. 2204..	0,750
DTGN R/L 3232 P22-N	32	32	170	34	40	TNM.. 2204..	1,300

Reference Bezeichnung							Nm
DTGN R/L 2020 K16-N	ITSN-342	1764	2708	1695	4294	5004	3.5
DTGN R/L 2525 M16-N	ITSN-342	1764	2708	1695	4294	5004	3.5
DTGN R/L 2525 M22-N	ITSN-433	1766	2712	1696	4295	5004	3.5
DTGN R/L 3232 P22-N	ITSN-433	1766	2712	1696	4295	5004	3.5

TNM..

Triangular negative inserts.
Dreikantige negative WSP. A45-46

Reference / Bez.

l s d

TNM.. 1604..	16,50	4,76	9,52
TNM.. 2204..	22,00	4,76	12,70

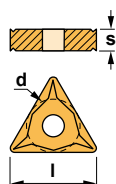

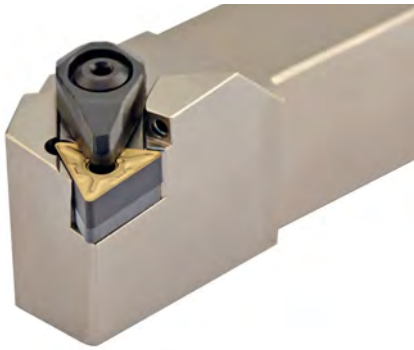

Characteristics:

Multipurpose toolholder equipped with triangular negative double-sided inserts (angle 60°).

For specific applications, roughing, semi-finishing and finishing.

Axial -6°
Radial -6°

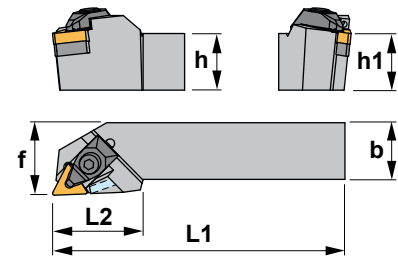

Eigenschaften:

Multifunktions-Klemmhalter mit doppelseitigen negativen dreieckigen Wendeschneidplatten (Winkel 60°).

Für spezifische Anwendungen, Schruppen, Vorschlichten und Schlichten.

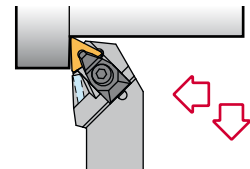

DTJN 93°-A

Reference Bezeichnung	h=h1	b	L1	L2	f	Insert size Wendeschneidplatte	Kg
DTJN R/L 2020 K16-A	20	20	125	32	25	TNM.. 1604..	0,400
DTJN R/L 2525 M16-A	25	25	150	32	32	TNM.. 1604..	0,700

Reference Bezeichnung										Nm
DTJN R/L 2020 K16-A	ITSN-342	1764	2708	1695	4294	5004	1506	1592	1598	3.5
DTJN R/L 2525 M16-A	ITSN-342	1764	2708	1695	4294	5004	1506	1592	1598	3.5

TNM..				Triangular negative inserts. Dreieckige negative WSP. A45-46	
Reference / Bez.	l	s	d		
TNM.. 1604..	16,50	4,76	9,52		



Characteristics: Toolholder for very specific operations equipped with rhombic negative inserts (angle 35°).

For low powered or poor rigid machines and small pieces, it is recommended to choose toolholder Ref. SVJC (Page: A157).

Axial -13°
Radial -4°

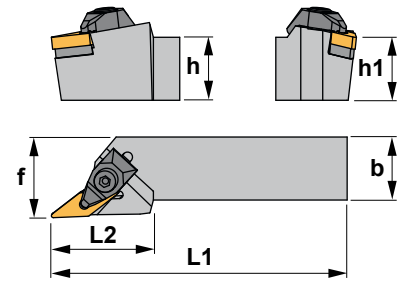

Eigenschaften:

Klemmhalter für sehr spezifische Anwendungen, bestückt mit rhombischen negativen Wendeschneidplatten (Winkel 35°). Für nicht stabile Maschinen, Maschinen mit einer niedrigen Leistung und für kleine Werkstücke empfehlen wir den Klemmhalter SVJC (Seite: A157).

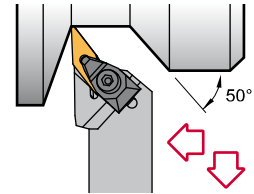

DVJN 93°-N

Reference Bezeichnung	h=h1	b	L1	L2	f	Insert size Wendeschneidplatte	Kg
DVJN R/L 2020 K16-N	20	20	125	34	25	VN.. 1604..	0,400
DVJN R/L 2525 M16-N	25	25	150	34	32	VN.. 1604..	0,700
DVJN R/L 3225 P16-N	32	25	170	34	32	VN.. 1604..	1,040
DVJN R/L 3232 P16-N	32	32	170	34	40	VN.. 1604..	1,250

Reference Bezeichnung							Nm
DVJN R/L 2020 K16-N	IVSN-322	1764	2708	1695	4294	5004	3.5
DVJN R/L 2525 M16-N	IVSN-322	1764	2708	1695	4294	5004	3.5
DVJN R/L 3225 P16-N	IVSN-322	1764	2708	1695	4294	5004	3.5
DVJN R/L 3232 P16-N	IVSN-322	1764	2708	1695	4294	5004	3.5

VN..

35° rhombic negative inserts. A49
35° rhombische negative Wendeschneidplatten.

Reference / Bez.	l	s	d
VN.. 1604..	16,50	4,76	9,52

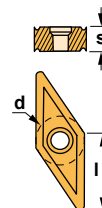

VNGP



VNMG



VNMG-TC



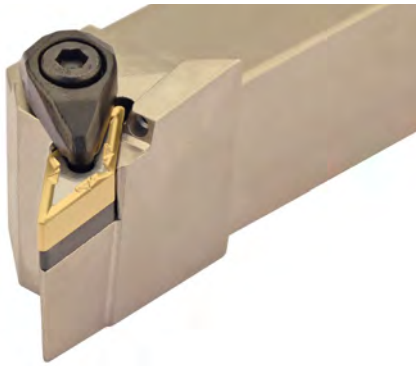

Characteristics: Toolholder for very specific operations equipped with rhombic negative inserts (angle 35°).

For low powered or poor rigid machines and small pieces, it is recommended to choose toolholder Ref. SVJC-A (Page: A158).

Axial -13°
Radial -4°

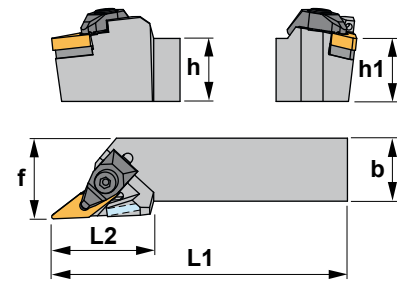

Eigenschaften:

Klemmhalter für sehr spezifische Anwendungen, bestückt mit rhombischen negativen Wendeschneidplatten (Winkel 35°). Für nicht stabile Maschinen, Maschinen mit einer niedrigen Leistung und für kleine Werkstücke empfehlen wir den Klemmhalter SVJC-A (Seite: A158).

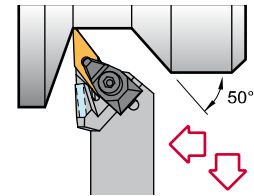

DVJN 93°-A

Reference Bezeichnung	h=h1	b	L1	L2	f	Insert size Wendeschneidplatte	Kg
DVJN R/L 2020 K16-A	20	20	125	34	25	VN.. 1604..	0,400
DVJN R/L 2525 M16-A	25	25	150	34	32	VN.. 1604..	0,700
DVJN R/L 3232 P16-A	32	32	170	34	40	VN.. 1604..	1,250

Reference Bezeichnung										Nm
DVJN R/L 2020 K16-A	IVSN-322	1764	2708	1695	4294	5004	1506	1592	1598	3.5
DVJN R/L 2525 M16-A	IVSN-322	1764	2708	1695	4294	5004	1506	1592	1598	3.5
DVJN R/L 3232 P16-A	IVSN-322	1764	2708	1695	4294	5004	-	1592	-	3.5

VN..

35° rhombic negative inserts. A49
35° rhombische negative Wendeschneidplatten.

Reference / Bez.	l	s	d
VN.. 1604..	16,50	4,76	9,52

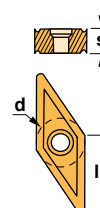

VNGP



VNMG



VNMG-TC





Characteristics:

Multipurpose toolholder equipped with trigon negative double-sided insert (angle 80°).

For top clamp toolholder see Ref. MWLN (Page: A92) or MWLN-K (Page: A93).

Axial -6°
Radial -6°

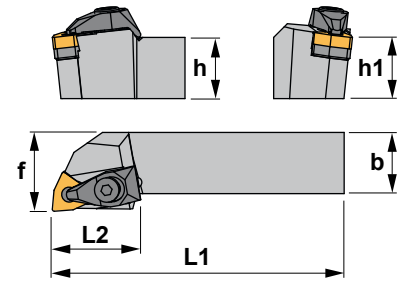

Eigenschaften:

Multifunktions-Klemmhalter mit doppelseitigen Trigon negativen Wendeschneidplatten (Winkel 80°).

Für Klemmhalter mit oberer Klemmung siehe MWLN (Seite: A92) oder MWLN-K (Seite: A93).

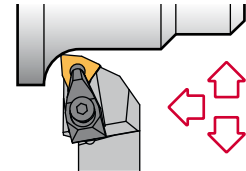

DWLN 95°-N

Reference Bezeichnung	h=h1	b	L1	L2	f	Insert size Wendeschneidplatte	
DWLN R/L 2020 K06-N	20	20	125	34	25	WNMG 0604..	0,400
DWLN R/L 2525 M06-N	25	25	150	34	25	WNMG 0604..	0,700
DWLN R/L 2020 K08-N	20	20	125	34	25	WNMG 0804..	0,400
DWLN R/L 2525 M08-N	25	25	150	34	32	WNMG 0804..	0,750
DWLN R/L 3232 P08-N	32	32	170	34	40	WNMG 0804..	1,300

Reference Bezeichnung							Nm
DWLN R/L 2020 K06-N	IWSN-322	1764	2708	1695	4294	5004	3.5
DWLN R/L 2525 M06-N	IWSN-322	1764	2708	1695	4294	5004	3.5
DWLN R/L 2020 K08-N	IWSN-433	1766	2712	1696	4295	5004	3.5
DWLN R/L 2525 M08-N	IWSN-433	1766	2712	1696	4295	5004	3.5
DWLN R/L 3232 P08-N	IWSN-433	1766	2712	1696	4295	5004	3.5

WNMG

80° trigon negative inserts. A50-51
80° trigon negative Wendeschneidplatten.

Reference / Bez.	l	s	d
WNMG 0604..	6,45	4,76	9,52
WNMG 0804..	8,14	4,76	12,70

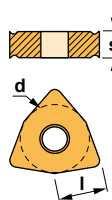



Characteristics:

Multipurpose toolholder equipped with trigon negative double-sided insert (angle 80°).

For top clamp toolholder see Ref. MWLN (Page: A92) or MWLN-K (Page: A93).

Axial -6°
Radial -6°

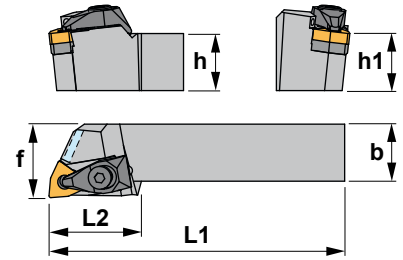

Eigenschaften:

Multifunktions-Klemmhalter mit doppelseitigen Trigon negativen Wendeschneidplatten (Winkel 80°).

Für Klemmhalter mit oberer Klemmung siehe MWLN (Seite: A92) oder MWLN-K (Seite: A93).

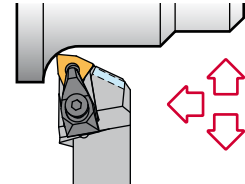

DWLN 95°-A

Reference Bezeichnung	h=h1	b	L1	L2	f	Insert size Wendeschneidplatte	kg
DWLN R/L 2020 K06-A	20	20	125	32	25	WNMG 0604..	0,400
DWLN R/L 2020 K08-A	20	20	125	32	25	WNMG 0804..	0,400
DWLN R/L 2525 M08-A	25	25	150	32	32	WNMG 0804..	0,700
DWLN R/L 3232 P08-A	32	32	170	32	38	WNMG 0804..	1,250

Reference Bezeichnung										Nm
DWLN R/L 2020 K06-A	IWSN-322	1764	2708	1695	4294	5004	1506	1592	1598	3.5
DWLN R/L 2020 K08-A	IWSN-433	1766	2712	1696	4295	5004	1506	1592	1598	3.5
DWLN R/L 2525 M08-A	IWSN-433	1766	2712	1696	4295	5004	1506	1592	1598	3.5
DWLN R/L 3232 P08-A	IWSN-433	1766	2712	1696	4295	5004	-	1592	-	3.5

WNMG

80° trigon negative inserts. A50-51
80° trigon negative Wendeschneidplatten.

Reference / Bez.	l	s	d
WNMG 0604..	6,45	4,76	9,52
WNMG 0804..	8,14	4,76	12,70

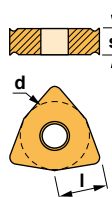



Characteristics:

Multipurpose toolholder equipped with rhombic negative double-sided insert (angle 80°).
For low powered machines and small pieces choose toolholder Ref. SCLC (Page: A132).

Axial -8°
Radial -6,5°

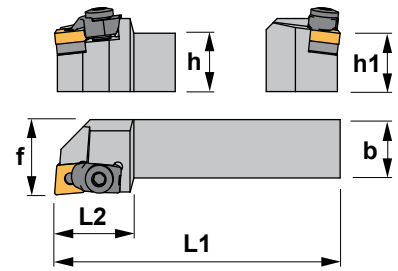

Eigenschaften:

Multifunktions-Klemmhalter mit doppelseitigen rhombischen negativen Wendeschneidplatten (Winkel 80°).
Für Niederleistungsmaschinen und kleine Werkstücke, wählen Sie Klemmhalter SCLC (Seite: A132).

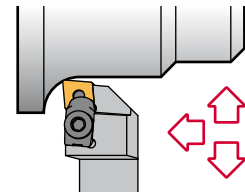

MCLN 95°

Reference Bezeichnung	h=h1	b	L1	L2	f	Insert size Wendeschneidplatte	/kg
MCLN R/L 2020 K12	20	20	125	34	25	CN.. 1204..	0,450
MCLN R/L 2525 M12	25	25	150	34	32	CN.. 1204..	0,800
MCLN R/L 3225 P12	32	25	170	34	32	CN.. 1204..	1,200
MCLN R/L 2525 M19	25	25	150	42	32	CN.. 1906..	0,800
MCLN R/L 3225 P19	32	25	170	42	32	CN.. 1906..	1,200
MCLN R/L 4040 S19	40	40	250	45	50	CN.. 1906..	3,100

Reference Bezeichnung						Nm
MCLN R/L 2020 K12	2015	5005	ICSN-432	1661	1394	4.0
MCLN R/L 2525 M12	2015	5005	ICSN-432	1661	1394	4.0
MCLN R/L 3225 P12	2015	5005	ICSN-432	1661	1394	4.0
MCLN R/L 2525 M19	2024	5005	3619	1682	1296	4.0
MCLN R/L 3225 P19	2024	5005	3619	1682	1296	4.0
MCLN R/L 4040 S19	2024	5005	3619	1682	1296	4.0

CN..

80° rhombic negative inserts. A32-34
80° rhombische negative WSP.

Reference / Bez.	l	s	d
CN.. 1204..	12,90	4,76	12,70
CN.. 1906..	19,30	6,35	19,05

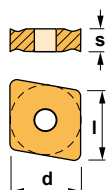



Characteristics:

Multipurpose toolholder equipped with rhombic negative double-sided insert (angle 80°). For low powered machines and small pieces choose toolholder Ref. SCLC (Page: A132).

Axial -8°
Radial -6,25°

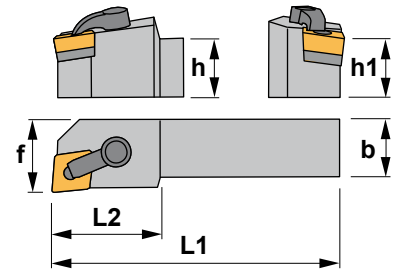

Eigenschaften:

Multifunktions-Klemmhalter mit doppelseitigen rhombischen negativen Wendeschneidplatten (Winkel 80°).

Für Niederleistungsmaschinen und kleine Werkstücke, wählen Sie Klemmhalter SCLC (Seite: A132).

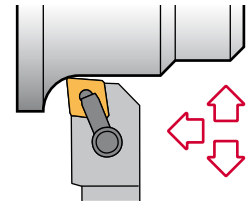

MCLN-K 95°

Reference Bezeichnung	h=h1	b	L1	L2	f	Insert size Wendeschneidplatte	Kg
MCLN R/L 2020 K12-K	20	20	125	28	25	CN.. 1204..	0,450
MCLN R/L 2525 M12-K	25	25	150	34	32	CN.. 1204..	0,800
MCLN R/L 3225 P12-K	32	25	170	34	32	CN.. 1204..	1,200
MCLN R/L 2525 M19-K	25	25	150	42	32	CN.. 1906..	0,800
MCLN R/L 3232 P19-K	32	32	170	42	40	CN.. 1906..	1,400

Reference Bezeichnung							Nm
MCLN R/L 2020 K12-K	2613	1086	5003	ICSN-432	1656	5025	3.0
MCLN R/L 2525 M12-K	2613	1086	5003	ICSN-432	1656	5025	3.0
MCLN R/L 3225 P12-K	2613	1086	5003	ICSN-432	1656	5025	3.0
MCLN R/L 2525 M19-K	2621	1098	5004	ICSN-633	1670	5004	3.5
MCLN R/L 3232 P19-K	2621	1098	5004	ICSN-633	1670	5004	3.5

CN..

80° rhombic negative inserts.
80° rhombische negative WSP. A32-34

Reference / Bez.	l	s	d
CN.. 1204..	12,90	4,76	12,70
CN.. 1906..	19,30	6,35	19,05

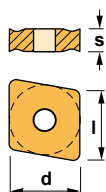



Characteristics:

Turning and profiling toolholder equipped with rhombic negative double-sided insert (angle 55°).

For low powered machines and small pieces choose toolholder Ref. SDJC (Page: A137).

Axial -6°
Radial -7°

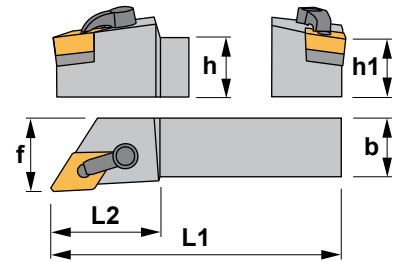

Eigenschaften:

Klemmhalter zum Drehen und Profildrehen mit doppelseitigen rhombischen negativen Wendeschneidplatten (Winkel 55°).

Für Niederleistungsmaschinen und kleine Werkstücke wählen Sie Klemmhalter SDJC (Seite: A137).

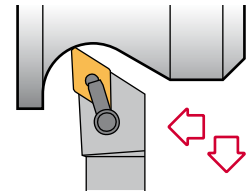

MDJN-K 93°

Reference Bezeichnung	h=h1	b	L1	L2	f	Insert size Wendeschneidplatte	Kg
MDJN R/L 2020 K15-K	20	20	125	42	25	DN.. 1506..	0,450
MDJN R/L 2525 M15-K	25	25	150	42	32	DN.. 1506..	0,800
MDJN R/L 3225 P15-K	32	25	170	42	32	DN.. 1506..	1,200

Reference Bezeichnung						Nm
MDJN R/L 2020 K15-K	2614	1086	5003	IDSN-432	1666 5025	3.0
MDJN R/L 2525 M15-K	2614	1086	5003	IDSN-432	1666 5025	3.0
MDJN R/L 3225 P15-K	2614	1086	5003	IDSN-432	1666 5025	3.0

DN.. 55° rhombic negative inserts. A36-37
55° rhombische negative Wendeschneidplatten.

Reference / Bez.	l	s	d
DN.. 1506..	15,50	6,35	12,70

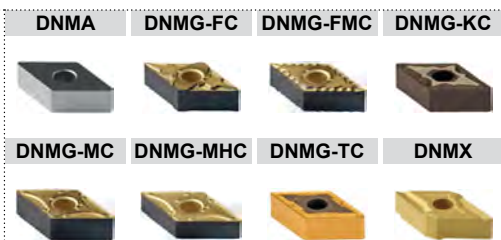
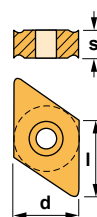

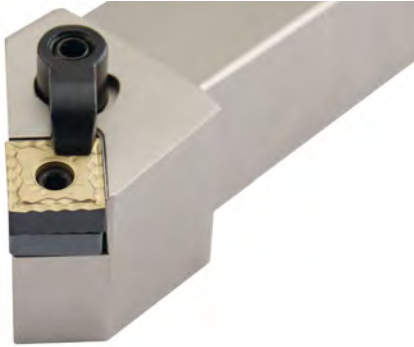

Characteristics: Toolholder for external turning and chamfering applications equipped with square negative inserts.
For low powered machines and small pieces choose toolholder Ref. CSSP (Page: A119) or SSSC (Page: A145).

Axial -6°
Radial -6°

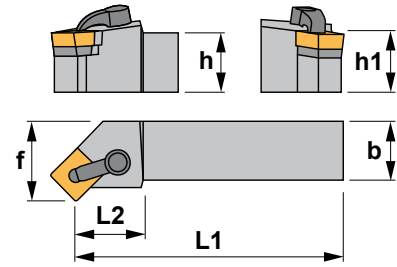

Eigenschaften:

Klemmhalter zum Außendrehen und Abschrägen mit vierkantigen Wendeschneidplatten.

Für Niederleistungsmaschinen und kleine Werkstücke, wählen Sie Klemmhalter CSSP (Seite: A119) oder SSSC (Seite: A145).

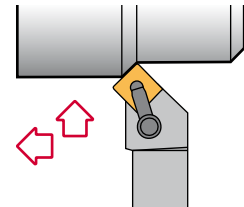

MSSN-K 45°

Reference Bezeichnung	h=h1	b	L1	L2	f	Insert size Wendeschneidplatte	kg
MSSN R/L 2020 K12-K	20	20	125	28	27	SNM.. 1204..	0,450
MSSN R/L 2525 M12-K	25	25	150	28	32	SNM.. 1204..	0,800

Reference Bezeichnung							Nm
MSSN R/L 2020 K12-K	2613	1086	5003	ISSN-432	1656	5025	3.0
MSSN R/L 2525 M12-K	2613	1086	5003	ISSN-432	1656	5025	3.0

SNM.. <small>Square negative inserts. Vierkantige negative Wendeschneidplatten. A41-42</small>						
Reference / Bez.	l	s	d			
SNM.. 1204..	12,70	4,76	12,70			

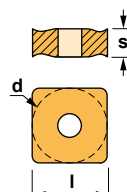

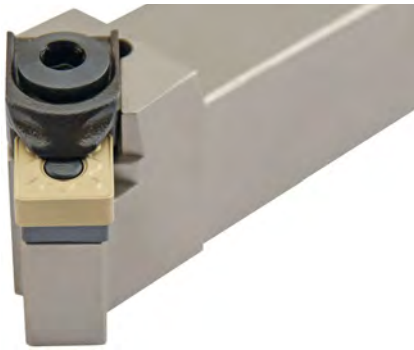

Characteristics:

Toolholder for external turning and chamfering applications equipped with square negative inserts.

For low powered machines and small pieces choose toolholder Ref. CSSP (Page: A119) or SSSC (Page: A145).

Axial -6°
Radial -6°

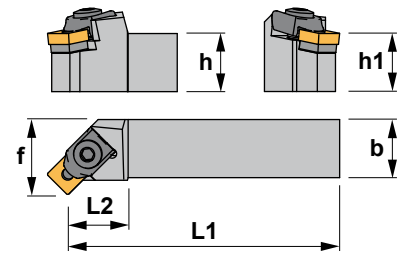

Eigenschaften:

Klemmhalter zum Außendrehen und Abschrägen mit vierkantigen negativen Wendeschneidplatten.

Für Niederleistungsmaschinen und kleine Werkstücke, wählen Sie Klemmhalter CSSP (Seite: A119) oder SSSC (Seite: A145).

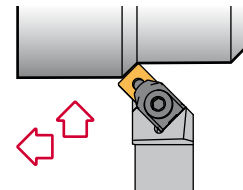

MSSN 45°

Reference Bezeichnung	h=h1	b	L1	L2	f	Insert size Wendeschneidplatte	
MSSN R/L 2020 K12	20	20	125	34	27	SNM.. 1204..	0,450
MSSN R/L 2525 M12	25	25	150	34	32	SNM.. 1204..	0,800
MSSN R/L 3225 P12	32	25	170	34	32	SNM.. 1204..	1,200
MSSN R/L 2525 M19	25	25	150	42	32	SNM.. 1906..	0,800
MSSN R/L 3225 P19	32	25	170	42	32	SNM.. 1906..	1,200
MSSN R/L 3232 P19	32	32	170	42	40	SNM.. 1906..	1,400
MSSN R/L 4040 S19	40	40	250	42	50	SNM.. 1906..	3,100

Reference Bezeichnung						Nm
MSSN R/L 2020 K12	2014	5005	3514	1661	1394	4.0
MSSN R/L 2525 M12	2014	5005	3514	1661	1394	4.0
MSSN R/L 3225 P12	2014	5005	3514	1661	1394	4.0
MSSN R/L 2525 M19	2024	5005	3519	1682	1296	4.0
MSSN R/L 3225 P19	2024	5005	3519	1682	1296	4.0
MSSN R/L 3232 P19	2024	5005	3519	1682	1296	4.0
MSSN R/L 4040 S19	2024	5005	3519	1682	1296	4.0

SNM..

Square negative inserts.
Vierkantige negative Wendeschneidplatten. A41-42

Reference / Bez.	l	s	d
SNM.. 1204..	12,70	4,76	12,70
SNM.. 1906..	19,05	6,35	19,05

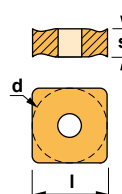

SNMG-FMC



SNMG-KC



SNMG-MHC



SNMG-RC



SNMG-TC



SNMM





Characteristics:

Profiling toolholder equipped with triangular negative double-sided insert (angle 60°).

For general applications, roughing, semi-finishing and finishing.

Axial -8,25°
Radial -2,25°

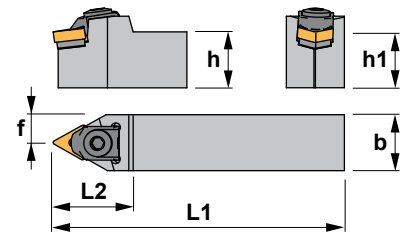

Eigenschaften:

Klemmhalter zum Profildrehen mit doppelseitigen dreikantigen negativen Wendeschneidplatten (Winkel 60°).

Für allgemeine Anwendungen, Schruppen, Vorschlichten und Schlichten.

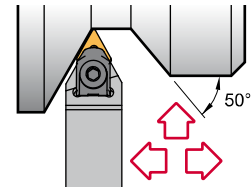

MTEN 60°

Reference Bezeichnung	h=h1	b	L1	L2	f	Insert size Wendeschneidplatte	kg
MTEN R/L/N 2020 K16	20	20	125	34	10,5	TNM.. 1604..	0,450
MTEN R/L/N 2525 M16	25	25	150	34	13,0	TNM.. 1604..	0,800
MTEN R/L/N 3225 P16	32	25	170	34	13,0	TNM.. 1604..	1,200
MTEN R/L/N 2525 M22	25	25	150	42	13,0	TNM.. 2204..	0,800
MTEN R/L/N 3225 P22	32	25	170	42	13,0	TNM.. 2204..	1,200
MTEN R/L/N 3232 P22	32	32	170	42	16,5	TNM.. 2204..	1,400
MTEN R/L/N 4025 R22	40	25	200	42	13,0	TNM.. 2204..	1,500
MTEN R/N 5032 S22	50	32	250	50	16,5	TNM.. 2204..	2,950

Reference Bezeichnung						Nm
MTEN R/L/N 2020 K16	2014	5005	3414	1642	1393	4.0
MTEN R/L/N 2525 M16	2014	5005	3414	1642	1393	4.0
MTEN R/L/N 3225 P16	2014	5005	3414	1642	1393	4.0
MTEN R/L/N 2525 M22	2024	5005	ITSN-433	1661	1394	4.0
MTEN R/L/N 3225 P22	2024	5005	ITSN-433	1661	1394	4.0
MTEN R/L/N 3232 P22	2024	5005	ITSN-433	1661	1394	4.0
MTEN R/L/N 4025 R22	2024	5005	ITSN-433	1661	1394	4.0
MTEN R/N 5032 S22	2024	5005	ITSN-433	1661	1394	4.0

TNM.. <small>Triangular negative inserts. Dreikantige negative WSP. A45-46</small>									
Reference / Bez.	l	s	d		TNMA	TNMG-CC	TNMG-FC	TNMG-FMC	TNMG-KC
TNM.. 1604..	16,50	4,76	9,52						
TNM.. 2204..	22,00	4,76	12,70						



Characteristics:

Turning and profiling toolholder equipped with triangular negative double-sided insert. For low powered machines and small pieces choose toolholder Ref. STJC (Page: A150).

Axial -6°
Radial -6°

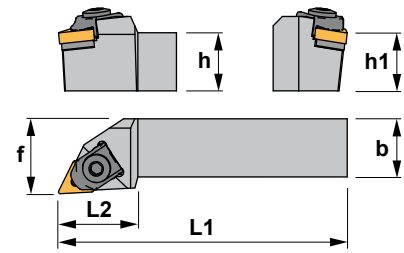

Eigenschaften:

Klemmhalter zum Drehen und Profildrehen mit doppelseitigen dreikantigen negativen Wendeschneidplatten.

Für Niederleistungsmaschinen und kleine Werkstücke, wählen Sie Klemmhalter STJC (Seite: A150).

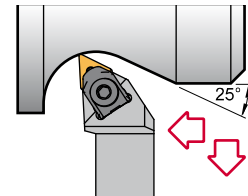

MTJN 93°

Reference Bezeichnung	h=h1	b	L1	L2	f	Insert size Wendeschneidplatte	Kg
MTJN R/L 2020 K16	20	20	125	34	25	TNM.. 1604..	0,450
MTJN R/L 2525 M16	25	25	150	34	32	TNM.. 1604..	0,800
MTJN R/L 3225 P16	32	25	170	34	32	TNM.. 1604..	1,200
MTJN R/L 2525 M22	25	25	150	38	32	TNM.. 2204..	0,800
MTJN R/L 3225 P22	32	25	170	42	32	TNM.. 2204..	1,200
MTJN R/L 3232 P22	32	32	170	42	40	TNM.. 2204..	1,400
MTJN R/L 4025 R22	40	25	200	42	32	TNM.. 2204..	1,500
MTJN R/L 5032 S22	50	32	250	42	40	TNM.. 2204..	2,950

Reference Bezeichnung						Nm
MTJN R/L 2020 K16	2014	5005	3414	1642	1393	4.0
MTJN R/L 2525 M16	2014	5005	3414	1642	1393	4.0
MTJN R/L 3225 P16	2014	5005	3414	1642	1393	4.0
MTJN R/L 2525 M22	2024	5005	ITSN-433	1661	1394	4.0
MTJN R/L 3225 P22	2024	5005	ITSN-433	1661	1394	4.0
MTJN R/L 3232 P22	2024	5005	ITSN-433	1661	1394	4.0
MTJN R/L 4025 R22	2024	5005	ITSN-433	1661	1394	4.0
MTJN R/L 5032 S22	2024	5005	ITSN-433	1661	1394	4.0

TNM..

Triangular negative inserts.
Dreikantige negative WSP. A45-46

Reference / Bez.	l	s	d
TNM.. 1604..	16,50	4,76	9,52
TNM.. 2204..	22,00	4,76	12,70

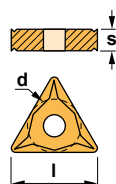

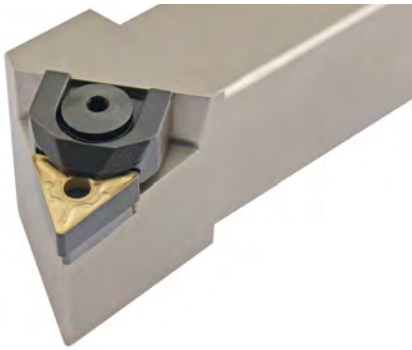

Characteristics:

Turning and profiling toolholder equipped with triangular negative double-sided insert. For low powered machines and small pieces choose toolholder Ref. STJC (Page: A150).

Axial -6°
Radial -6°

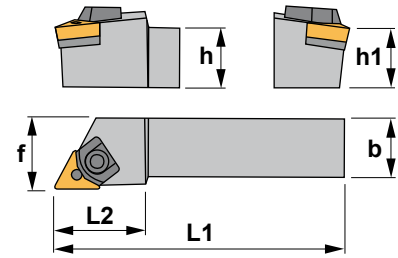

Eigenschaften:

Klemmhalter zum Drehen und Profildrehen mit doppelseitigen dreikantigen negativen Wendeschneidplatten.

Für Niederleistungsmaschinen und kleine Werkstücke, wählen Sie Klemmhalter STJC (Seite: A150).

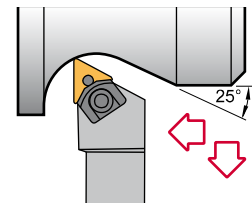

MTJN-K 93°

Reference Bezeichnung	h=h1	b	L1	L2	f	Insert size Wendeschneidplatte	Kg
MTJN R/L 2020 K16-K	20	20	125	34	25	TNM.. 1604..	0,450
MTJN R/L 2525 M16-K	25	25	150	34	32	TNM.. 1604..	0,800
MTJN R/L 2525 M22-K	25	25	150	34	32	TNM.. 2204..	0,800
MTJN R/L 3225 P22-K	32	25	170	34	32	TNM.. 2204..	1,200
MTJN R/L 3232 P22-K	32	32	170	42	40	TNM.. 2204..	1,400
MTJN R/L 4025 R22-K	40	25	200	34	32	TNM.. 2204..	1,500
MTJN R/L 5032 S22-K	50	32	250	34	40	TNM.. 2204..	2,950

Reference Bezeichnung						Nm
MTJN R/L 2020 K16-K	2017	5025	3414	1642	1393	2.0
MTJN R/L 2525 M16-K	2017	5025	3414	1642	1393	2.0
MTJN R/L 2525 M22-K	2023	5003	ITSN-433	1642	1393	3.0
MTJN R/L 3225 P22-K	2023	5003	ITSN-433	1661	1394	3.0
MTJN R/L 3232 P22-K	2023	5003	ITSN-433	1661	1394	3.0
MTJN R/L 4025 R22-K	2023	5003	ITSN-433	1661	1394	3.0
MTJN R/L 5032 S22-K	2023	5003	ITSN-433	1661	1394	3.0

TNM..				Triangular negative inserts. Dreikantige negative WSP. A45-46					
Reference / Bez.	l	s	d		TNMA	TNMG-CC	TNMG-FC	TNMG-FMC	TNMG-KC
TNM.. 1604..	16,50	4,76	9,52						
TNM.. 2204..	22,00	4,76	12,70						



Characteristics:

Profiling toolholder equipped with triangular negative double-sided insert (angle 60°).

For general applications, roughing, semi-finishing and finishing.

Axial -8°
Radial -2,5°

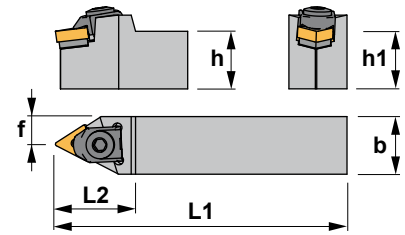

Eigenschaften:

Klemmhalter zum Profildrehen mit doppelseitigen dreikantigen Wendeschneidplatten (Winkel 60°). Für allgemeine Anwendungen, Schruppen, Vorschlichten und Schlichten.

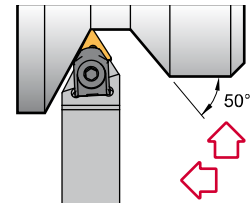

MTNN 63°

Reference Bezeichnung	h=h1	b	L1	L2	f	Insert size Wendeschneidplatte	Kg
MTNN R/L 2020 K16	20	20	125	34	10,0	TNM.. 1604..	0,450
MTNN R/L 2525 M16	25	25	150	34	12,5	TNM.. 1604..	0,800
MTNN R/L 3225 P16	32	25	170	34	12,5	TNM.. 1604..	1,200
MTNN R/L 2525 M22	25	25	150	42	12,5	TNM.. 2204..	0,800
MTNN R/L 3225 P22	32	25	170	42	12,5	TNM.. 2204..	1,200
MTNN R/L 3232 P22	32	32	170	42	16,0	TNM.. 2204..	1,400
MTNN R/L 4025 R22	40	25	200	42	12,5	TNM.. 2204..	1,500
MTNN L 5032 S22	50	32	250	50	16,0	TNM.. 2204..	2,950

Reference Bezeichnung						Nm
MTNN R/L 2020 K16	2014	5005	3414	1642	1393	4.0
MTNN R/L 2525 M16	2014	5005	3414	1642	1393	4.0
MTNN R/L 3225 P16	2014	5005	3414	1642	1393	4.0
MTNN R/L 2525 M22	2024	5005	ITSN-433	1661	1394	4.0
MTNN R/L 3225 P22	2024	5005	ITSN-433	1661	1394	4.0
MTNN R/L 3232 P22	2024	5005	ITSN-433	1661	1394	4.0
MTNN R/L 4025 R22	2024	5005	ITSN-433	1661	1394	4.0
MTNN L 5032 S22	2024	5005	ITSN-433	1661	1394	4.0

TNM..

Triangular negative inserts.
Dreikantige negative WSP. A45-46

Reference / Bez.	l	s	d
TNM.. 1604..	16,50	4,76	9,52
TNM.. 2204..	22,00	4,76	12,70

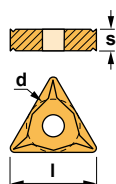



Characteristics:

External turning and profiling toolholder equipped with rhombic negative double-sided insert (angle 35°).

For low powered machines and small pieces choose toolholder Ref. SVJC (Page: A157).

Axial -6°
Radial -6°

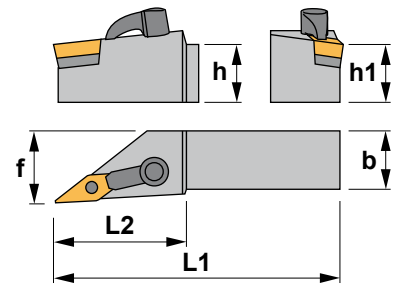

Eigenschaften:

Klemhalter zum Außendrehen und Profildrehen mit doppelseitigen rhombischen negativen Wendeschneidplatten (Winkel 35°).

Für Niederleistungsmaschinen und kleine Werkstücke, wählen Sie Klemhalter SVJC (Seite: A157).

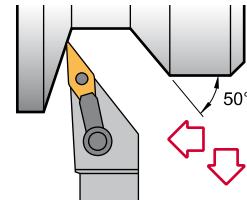

MVJN-K 93°

Reference Bezeichnung	h=h1	b	L1	L2	f	Insert size Wendeschneidplatte	kg
MVJN R/L 2020 K16-K	20	20	125	42	25	VN.. 1604..	0,450
MVJN R/L 2525 M16-K	25	25	150	42	32	VN.. 1604..	0,800
MVJN R/L 3225 P16-K	32	25	170	42	32	VN.. 1604..	1,200

Reference Bezeichnung							Nm
MVJN R/L 2020 K16-K	2616	1086	5003	IVSN-322	1665	5002	3.0
MVJN R/L 2525 M16-K	2616	1086	5003	IVSN-322	1665	5002	3.0
MVJN R/L 3225 P16-K	2616	1086	5003	IVSN-322	1665	5002	3.0

VN..	35° rhombic negative inserts. A49 35° rhombische negative Wendeschneidplatten.			
	Reference / Bez.	l	s	d
VN.. 1604..	16,50	4,76	9,52	

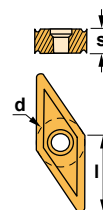

VNGP	VNMG
VNMG-TC	



Characteristics:

Turning and profiling toolholder equipped with rhombic negative double-sided insert (angle 35°).

For general applications, roughing, semi-finishing and finishing.

Axial -8°
Radial -10°

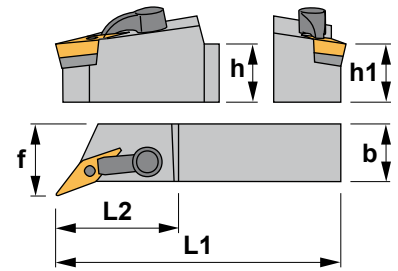

Eigenschaften:





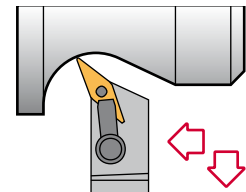

Klemmhalter zum Drehen und Profildrehen mit doppelseitigen rhombischen negativen Wendeschneidplatten (Winkel 35°).

Für allgemeine Anwendungen, Schruppen, Vorschlichten und Schlichten.



MVQN-K 117°30'

Reference Bezeichnung	h=h1	b	L1	L2	f	Insert size Wendeschneidplatte	
MVQN R/L 2020 K16-K	20	20	125	42	25	VN.. 1604..	0,450
MVQN R/L 2525 M16-K	25	25	150	42	32	VN.. 1604..	0,800
MVQN R/L 3225 P16-K	32	25	170	42	32	VN.. 1604..	1,200

Reference Bezeichnung							Nm
MVQN R/L 2020 K16-K	2616	1086	5003	IVSN-322	1665	5002	3.0
MVQN R/L 2525 M16-K	2616	1086	5003	IVSN-322	1665	5002	3.0
MVQN R/L 3225 P16-K	2616	1086	5003	IVSN-322	1665	5002	3.0

VN..

35° rhombic negative inserts.  A49
35° rhombische negative Wendeschneidplatten.

Reference / Bez.	l	s	d
VN.. 1604..	16,50	4,76	9,52

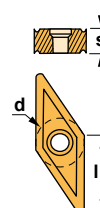

VNGP



VNMG



VNMG-TC





Characteristics:

Profiling toolholder equipped with rhombic negative double-sided insert (angle 35°).
For low powered machines and small pieces choose toolholder Ref. SVVC (Page: A162).

Axial 6°
Radial 0°

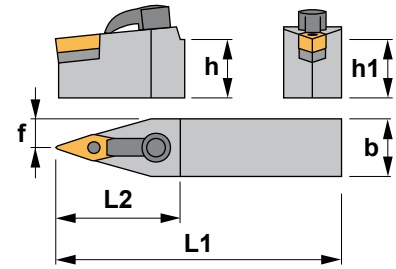

Eigenschaften:

Klemmhalter zum Drehen und Profildrehen mit doppelseitigen rhombischen negativen Wendeschneidplatten (Winkel 35°).
Für Niederleistungsmaschinen und kleine Werkstücke, wählen Sie Klemmhalter SVVC (Seite: A162).

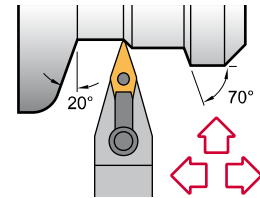

MVVN-K 72°30'

Reference Bezeichnung	h=h1	b	L1	L2	f	Insert size Wendeschneidplatte	Kg
MVVN N 2020 K16-K	20	20	125	42	10,0	VN.. 1604..	0,450
MVVN N 2525 M16-K	25	25	150	42	12,5	VN.. 1604..	0,800

Reference Bezeichnung							Nm
MVVN N 2020 K16-K	2616	1086	5003	IVSN-322	1665	5002	3.0
MVVN N 2525 M16-K	2616	1086	5003	IVSN-322	1665	5002	3.0

VN..	35° rhombic negative inserts. 35° rhombische negative Wendeschneidplatten. A49		
Reference / Bez.	l	s	d
VN.. 1604..	16,50	4,76	9,52

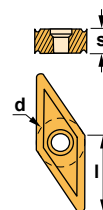

VNGP	VNMG
VNMG-TC	

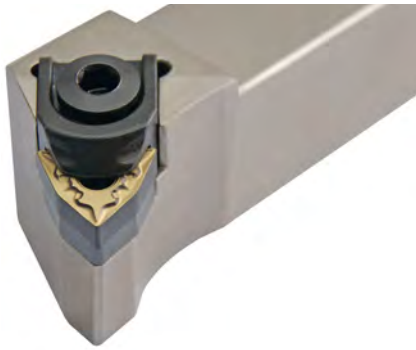

Characteristics:

Multipurpose toolholder equipped with trigon negative double-sided insert (angle 80°).

Not suitable for cermet, ceramic or K10 and P10 grade inserts.

Axial -6,5°
Radial -6,5°

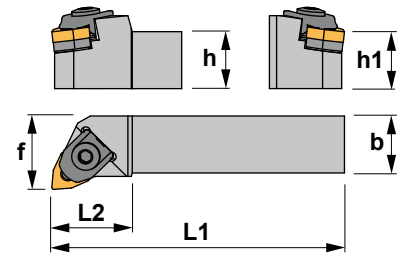

Eigenschaften:

Multifunktions-Klemmhalter mit doppelseitigen Trigon negativen Wendeschneidplatten (80° Winkel).

Nicht geeignet für Cermet, Keramik oder K10 und P10 Wendeschneidplatten.

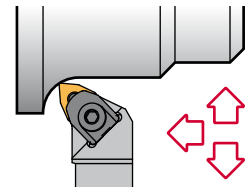

MWLN 95°

Reference Bezeichnung	h=h1	b	L1	L2	f	Insert size Wendeschneidplatte	kg
MWLN R/L 1616 H06	16	16	100	15	20	WNMG 0604..	0,200
MWLN R/L 2020 K06	20	20	125	22	25	WNMG 0604..	0,450
MWLN R/L 2525 M06	25	25	150	28	32	WNMG 0604..	0,800
MWLN R/L 2020 K08	20	20	125	34	25	WNMG 0804..	0,450
MWLN R/L 2525 M08	25	25	150	34	32	WNMG 0804..	0,800
MWLN R/L 3225 P08	32	25	170	34	32	WNMG 0804..	1,200
MWLN R/L 3232 P08	32	32	170	34	40	WNMG 0804..	1,400

Reference Bezeichnung						Nm
MWLN R/L 1616 H06	2006	5025	3006	1644	1393	2.0
MWLN R/L 2020 K06	2006	5025	3006	1642	1393	2.0
MWLN R/L 2525 M06	2006	5025	3006	1642	1393	2.0
MWLN R/L 2020 K08	2011	5005	IWSN-433	1661	1394	4.0
MWLN R/L 2525 M08	2011	5005	IWSN-433	1661	1394	4.0
MWLN R/L 3225 P08	2011	5005	IWSN-433	1661	1394	4.0
MWLN R/L 3232 P08	2011	5005	IWSN-433	1661	1394	4.0

WNMG 80° trigon negative inserts. A50-51
80° trigon negative Wendeschneidplatten.

Reference / Bez.	l	s	d
WNMG 0604..	6,45	4,76	9,52
WNMG 0804..	8,14	4,76	12,70

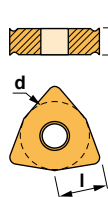

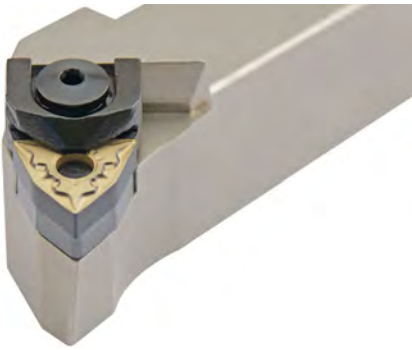

Characteristics:

Multipurpose toolholder equipped with trigon negative double-sided insert (angle 80°). Especially recommended for cermet, ceramic or K10 and P10 grade inserts.

Axial -5,5°
Radial -6,5°

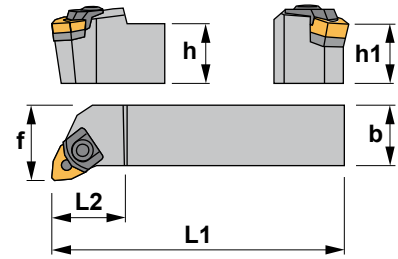

Eigenschaften:

Multifunktions-Klemmhalter mit doppelseitigen Trigon negativen Wendeschneidplatten (80° Winkel).

Besonders empfohlen für Cermet, Keramik oder K10 und P10 Wendeschneidplatten.

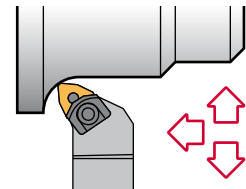

MWLN-K 95°

Reference Bezeichnung	h=h1	b	L1	L2	f	Insert size Wendeschneidplatte	kg
MWLN R/L 2020 K08-K	20	20	125	34	25	WNM.. 0804..	0,450
MWLN R/L 2525 M08-K	25	25	150	34	32	WNM.. 0804..	0,800
MWLN R/L 3232 P08-K	32	32	170	34	40	WNM.. 0804..	1,400

Reference Bezeichnung						Nm
MWLN R/L 2020 K08-K	2018	5025	IWSN-433	1661	1394	2.0
MWLN R/L 2525 M08-K	2018	5025	IWSN-433	1661	1394	2.0
MWLN R/L 3232 P08-K	2018	5025	IWSN-433	1661	1394	2.0

WNMG 80° trigon negative inserts. A50-51
80° trigon negative Wendeschneidplatten.

Reference / Bez.	l	s	d
WNMG 0804..	8,14	4,76	12,70

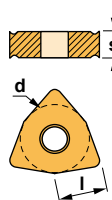



Characteristics:

Toolholder for external turning applications equipped with rhombic negative inserts (angle 80°).

For general applications, roughing, semi-finishing and finishing.

Axial -7,25°
Radial -4,25°

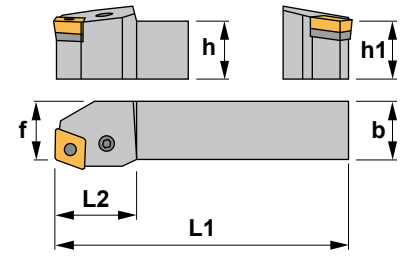

Eigenschaften:

Klemmhalter zum Außendrehen mit rhombischen negativen Wendeschneidplatten (80° Winkel).

Für allgemeine Anwendungen, Schruppen, Vorschlichten und Schlichten.

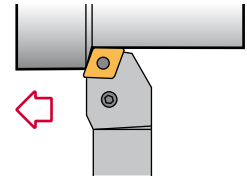

PCBN 75°

Reference Bezeichnung	h=h1	b	L1	L2	f	Insert size Wendeschneidplatte	
PCBN R/L 2020 K12	20	20	125	28	17	CN.. 1204..	0,400
PCBN R/L 2525 M12	25	25	150	28	22	CN.. 1204..	0,750
PCBN R/L 3225 P12	32	25	170	34	22	CN.. 1204..	0,750
PCBN R/L 2525 M16	25	25	150	34	22	CN.. 1606..	0,750
PCBN R/L 3225 P16	32	25	170	34	22	CN.. 1606..	1,050
PCBN R/L 3232 P16	32	32	170	34	27	CN.. 1606..	1,300
PCBN R/L 3225 P19	32	25	170	38	22	CN.. 1906..	1,050
PCBN R/L 3232 P19	32	32	170	42	27	CN.. 1906..	1,300
PCBN R/L 4040 S19	40	40	250	48	35	CN.. 1906..	3,050
PCBN R/L 4040 S25	40	40	250	48	35	CN.. 2509..	3,050
PCBN R/L 5050 T25	50	50	300	50	45	CN.. 2509..	5,800

Reference Bezeichnung							Nm
PCBN R/L 2020 K12	8012	1608	5003	3612	4112	0012	3.0
PCBN R/L 2525 M12	8012	1608	5003	3612	4112	0012	3.0
PCBN R/L 3225 P12	8012	1608	5003	3612	4112	0012	3.0
PCBN R/L 2525 M16	8016	1618	5003	3616	4115	0015	3.0
PCBN R/L 3225 P16	8016	1618	5003	3616	4115	0015	3.0
PCBN R/L 3232 P16	8016	1618	5003	3616	4115	0015	3.0
PCBN R/L 3225 P19	8019	1610	5004	3619	4119	0019	3.5
PCBN R/L 3232 P19	8019	1610	5004	3619	4119	0019	3.5
PCBN R/L 4040 S19	8019	1610	5004	3619	4119	0019	3.5
PCBN R/L 4040 S25	8025	1612	5005	3625	4125	0025	4.0
PCBN R/L 5050 T25	8025	1612	5005	3625	4125	0025	4.0

CN..

80° rhombic negative inserts.
80° rhombische negative WSP. A32-34

Reference / Bez.	l	s	d
CN.. 1204..	12,90	4,76	12,70
CN.. 1606..	16,10	6,35	15,88
CN.. 1906..	19,30	6,35	19,05
CN.. 2509..	25,80	9,52	25,40

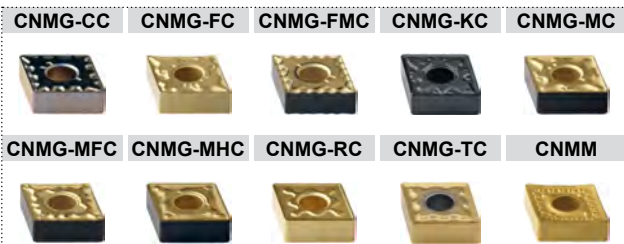
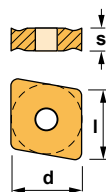



Characteristics:

Toolholder for face turning applications equipped with rhombic negative inserts (angle 80°).

For general applications, roughing, semi-finishing and finishing.

Axial -6°
Radial -6°

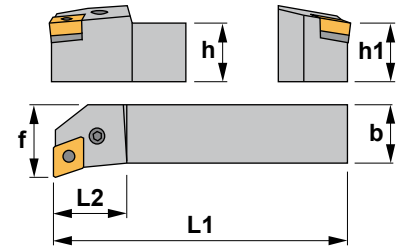

Eigenschaften:

Klemmhalter zum Plandrehen mit doppelseitigen rhombischen negativen Wendschneidplatten (80° Winkel).

Für allgemeine Anwendungen, Schruppen, Vorschlichten und Schlichten.



PCFN 90°

Reference Bezeichnung	h=h1	b	L1	L2	f	Insert size Wendschneidplatte	
PCFN R/L 2525 M12	25	25	150	28	32	CN.. 1204..	0,750
PCFN R/L 2525 M16	25	25	150	34	32	CN.. 1606..	0,750
PCFN R/L 3225 P16	32	25	170	34	32	CN.. 1606..	1,050
PCFN R/L 3232 P16	32	32	170	34	40	CN.. 1606..	1,300
PCFN R/L 3225 P19	32	25	170	34	32	CN.. 1906..	1,050
PCFN R/L 3232 P19	32	32	170	42	40	CN.. 1906..	1,300
PCFN R/L 4040 S19	40	40	250	45	50	CN.. 1906..	3,050

Reference Bezeichnung							Nm
PCFN R/L 2525 M12	8012	1608	5003	3612	4112	0012	3.0
PCFN R/L 2525 M16	8016	1618	5003	3616	4115	0015	3.0
PCFN R/L 3225 P16	8016	1618	5003	3616	4115	0015	3.0
PCFN R/L 3232 P16	8016	1618	5003	3616	4115	0015	3.0
PCFN R/L 3225 P19	8019	1610	5004	3619	4119	0019	3.5
PCFN R/L 3232 P19	8019	1610	5004	3619	4119	0019	3.5
PCFN R/L 4040 S19	8019	1610	5004	3619	4119	0019	3.5

CN..

80° rhombic negative inserts.
80° rhombische negative WSP. A32-34

Reference / Bez.	l	s	d
CN.. 1204..	12,90	4,76	12,70
CN.. 1606..	16,10	6,35	15,88
CN.. 1906..	19,30	6,35	19,05

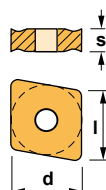



Characteristics:

Toolholder for face turning applications equipped with rhombic negative inserts (angle 80°).

For general applications, roughing, semi-finishing and finishing.

Axial -6,5°
Radial -5,5°

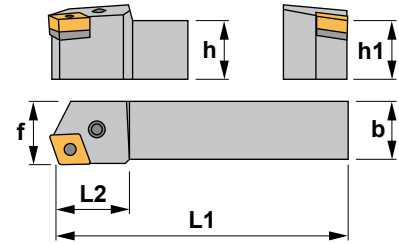

Eigenschaften:

Klemmhalter zum Plandrehen mit doppelseitigen rhombischen negativen Wendeschneidplatten (80° Winkel).

Für allgemeine Anwendungen, Schruppen, Vorschlichten und Schlichten.



PCKN 75°

Reference Bezeichnung	h=h1	b	L1	L2	f	Insert size Wendeschneidplatte	
PCKN R/L 2020 K12	20	20	125	28	25	CN.. 1204..	0,400
PCKN R/L 2525 M12	25	25	150	28	32	CN.. 1204..	0,750
PCKN R/L 3225 P12	32	25	170	28	32	CN.. 1204..	1,050
PCKN R/L 3232 P19	32	32	170	34	40	CN.. 1906..	1,300
PCKN R/L 4040 S19	40	40	250	45	50	CN.. 1906..	3,050
PCKN R/L 4040 S25	40	40	250	45	50	CN.. 2509..	3,050
PCKN R/L 5050 T25	50	50	300	45	60	CN.. 2509..	5,850

Reference Bezeichnung							Nm
PCKN R/L 2020 K12	8012	1608	5003	3612	4112	0012	3.0
PCKN R/L 2525 M12	8012	1608	5003	3612	4112	0012	3.0
PCKN R/L 3225 P12	8012	1608	5003	3612	4112	0012	3.0
PCKN R/L 3232 P19	8019	1610	5004	3619	4119	0019	3.5
PCKN R/L 4040 S19	8019	1610	5004	3619	4119	0019	3.5
PCKN R/L 4040 S25	8025	1612	5005	3625	4125	0025	4.0
PCKN R/L 5050 T25	8025	1612	5005	3625	4125	0025	4.0

CN..

80° rhombic negative inserts. A32-34
80° rhombische negative WSP.

Reference / Bez.	l	s	d
CN.. 1204..	12,90	4,76	12,70
CN.. 1906..	19,30	6,35	19,05
CN.. 2509..	25,80	9,52	25,40

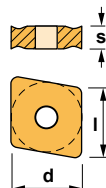

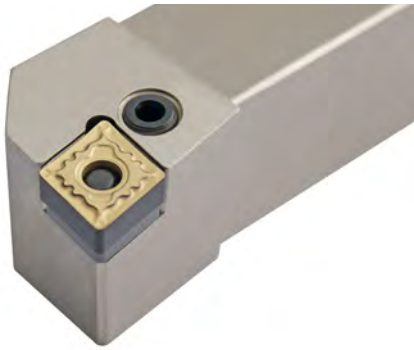

Characteristics:

Multipurpose toolholder equipped with rhombic negative double-sided insert (angle 80°). For low powered machines and small pieces choose toolholder Ref. SCLC (Page: A132).

Axial -6,5°
Radial -6,5°

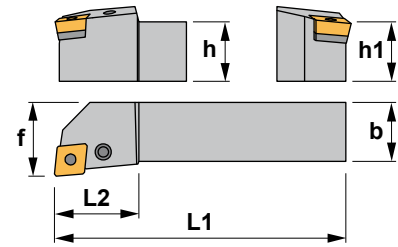

Eigenschaften:

Multifunktions-Klemmhalter mit doppelseitigen rhombischen negativen Wendeschneidplatten (80° Winkel). Für Niederleistungsmaschinen und kleine Werkstücke, wählen Sie Klemmhalter SCLC (Seite: A132).

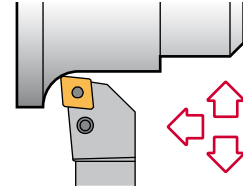

PCLN 95°

Reference Bezeichnung	h=h1	b	L1	L2	f	Insert size Wendeschneidplatte	Kg
PCLN R/L 1616 H09	16	16	100	25	20	CN.. 0903..	0,250
PCLN R/L 2020 K09	20	20	125	28	25	CN.. 0903..	0,400
PCLN R/L 2525 M09	25	25	150	28	32	CN.. 0903..	0,750
PCLN R/L 1616 H12	16	16	100	25	20	CN.. 1204..	0,250
PCLN R/L 2020 K12	20	20	125	28	25	CN.. 1204..	0,400
PCLN R/L 2525 M12	25	25	150	28	32	CN.. 1204..	0,750
PCLN R/L 3225 P12	32	25	170	28	32	CN.. 1204..	1,050
PCLN R/L 3232 P12	32	32	170	28	40	CN.. 1204..	1,300
PCLN R/L 2525 M16	25	25	150	34	32	CN.. 1606..	0,750
PCLN R/L 3225 P16	32	25	170	34	32	CN.. 1606..	1,050
PCLN R/L 3232 P16	32	32	170	34	40	CN.. 1606..	1,300
PCLN R/L 4040 S16	40	40	250	45	50	CN.. 1606..	3,050
PCLN R/L 2525 M19	25	25	150	42	32	CN.. 1906..	0,750
PCLN R/L 3225 P19	32	25	170	42	32	CN.. 1906..	1,050
PCLN R/L 3232 P19	32	32	170	42	40	CN.. 1906..	1,300
PCLN R/L 4040 S19	40	40	250	45	50	CN.. 1906..	3,050
PCLN R/L 5050 T19	50	50	300	50	60	CN.. 1906..	3,050
PCLN R/L 4040 S25	40	40	250	45	50	CN.. 2509..	3,050
PCLN R/L 5050 T25	50	50	300	50	60	CN.. 2509..	5,850

Reference Bezeichnung							Nm
PCLN R/L.....09	8009	1606	5025	3609	4109	0009	2.0
PCLN R/L.....H12	8312	1648	5003	3612	4112	0012	3.0
PCLN R/L.....12	8012	1608	5003	3612	4112	0012	3.0
PCLN R/L.....16	8016	1618	5003	3616	4115	0015	3.0
PCLN R/L.....19	8019	1610	5004	3619	4119	0019	3.5
PCLN R/L.....25	8025	1612	5005	3625	4125	0025	4.0

CN..

80° rhombic negative inserts.
80° rhombische negative WSP. A32-34

Reference / Bez.	l	s	d
CN.. 0903..	9,65	3,18	9,52
CN.. 1204..	12,90	4,76	12,70
CN.. 1606..	16,10	6,35	15,88
CN.. 1906..	19,30	6,35	19,05
CN.. 2509..	25,80	9,52	25,40

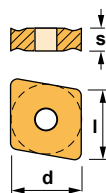

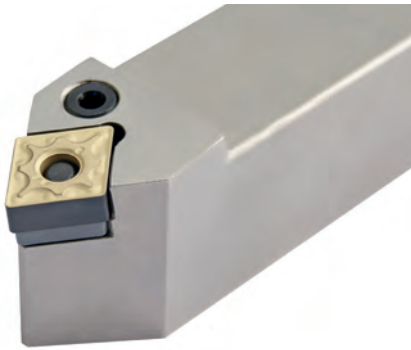

Characteristics:

Profiling toolholder equipped with rhombic negative double-sided insert (angle 80°).
For general applications, roughing, semi-finishing and finishing.

Axial -6°
Radial 0°

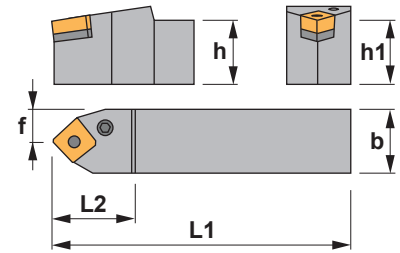

Eigenschaften:

Klemmhalter zum Profildrehen mit doppelseitigen rhombischen negativen Wendeschneidplatten (80° Winkel).

Für allgemeine Anwendungen, Schruppen, Vorschlichten und Schlichten.

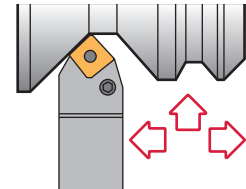

PCMN 50°

Reference Bezeichnung	h=h1	b	L1	L2	f	Insert size Wendeschneidplatte	Kg
PCMN N 2020 K12	20	20	125	34	10,0	CN.. 1204..	0,400
PCMN N 2525 M12	25	25	150	34	12,5	CN.. 1204..	0,750
PCMN N 3225 P12	32	25	170	34	12,5	CN.. 1204..	1,050
PCMN N 3232 P19	32	32	170	42	16,0	CN.. 1906..	1,300
PCMN N 4040 S19	40	40	250	48	20,0	CN.. 1906..	3,050
PCMN N 4040 S25	40	40	250	48	20,0	CN.. 2509..	3,050
PCMN N 5050 T25	50	50	300	50	25,0	CN.. 2509..	5,850

Reference Bezeichnung							Nm
PCMN N 2020 K12	8012	1608	5003	3612	4112	0012	3.0
PCMN N 2525 M12	8012	1608	5003	3612	4112	0012	3.0
PCMN N 3225 P12	8012	1608	5003	3612	4112	0012	3.0
PCMN N 3232 P19	8019	1610	5004	3619	4119	0019	3.5
PCMN N 4040 S19	8019	1610	5004	3619	4119	0019	3.5
PCMN N 4040 S25	8025	1612	5005	3625	4125	0025	4.0
PCMN N 5050 T25	8025	1612	5005	3625	4125	0025	4.0

CN..

80° rhombic negative inserts. A32-34
80° rhombische negative WSP.

Reference / Bez.	l	s	d
CN.. 1204..	12,90	4,76	12,70
CN.. 1906..	19,30	6,35	19,05
CN.. 2509..	25,80	9,52	25,40

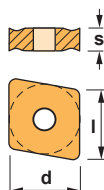



Characteristics:

Toolholder for external turning applications equipped with rhombic negative inserts (angle 80°).

For general applications, roughing, semi-finishing and finishing.

Axial -5,75°
Radial -5,75°

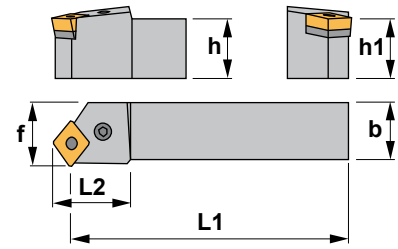

Eigenschaften:

Klemmhalter zum Außendrehen mit rhombischen negativen Wendeschneidplatten (80° Winkel).

Für allgemeine Anwendungen, Schruppen, Vorschlichten und Schlichten.

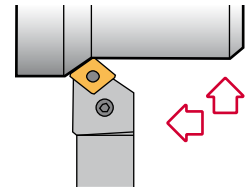

PCSN 45°

Reference Bezeichnung	h=h1	b	L1	L2	f	Insert size Wendeschneidplatte	Kg
PCSN R/L 2020 K12	20	20	125	28	25	CN.. 1204..	0,400
PCSN R/L 2525 M12	25	25	150	28	32	CN.. 1204..	0,750
PCSN R/L 2525 M16	25	25	150	34	32	CN.. 1606..	0,750
PCSN R/L 3225 P16	32	25	170	34	32	CN.. 1606..	1,050
PCSN R/L 3232 P16	32	32	170	42	40	CN.. 1606..	1,300
PCSN R/L 3225 P19	32	25	170	42	32	CN.. 1906..	1,050
PCSN R/L 3232 P19	32	32	170	42	40	CN.. 1906..	1,300
PCSN R/L 4040 S19	40	40	250	42	50	CN.. 1906..	3,050

Reference Bezeichnung							Nm
PCSN R/L 2020 K12	8012	1608	5003	3612	4112	0012	3.0
PCSN R/L 2525 M12	8012	1608	5003	3612	4112	0012	3.0
PCSN R/L 2525 M16	8016	1618	5003	3616	4115	0015	3.0
PCSN R/L 3225 P16	8016	1618	5003	3616	4115	0015	3.0
PCSN R/L 3232 P16	8016	1618	5003	3616	4115	0015	3.0
PCSN R/L 3225 P19	8019	1610	5004	3619	4119	0019	3.5
PCSN R/L 3232 P19	8019	1610	5004	3619	4119	0019	3.5
PCSN R/L 4040 S19	8019	1610	5004	3619	4119	0019	3.5

CN..

80° rhombic negative inserts.
80° rhombische negative WSP. A32-34

Reference / Bez.	l	s	d
CN.. 1204..	12,90	4,76	12,70
CN.. 1606..	16,10	6,35	15,88
CN.. 1906..	19,30	6,35	19,05

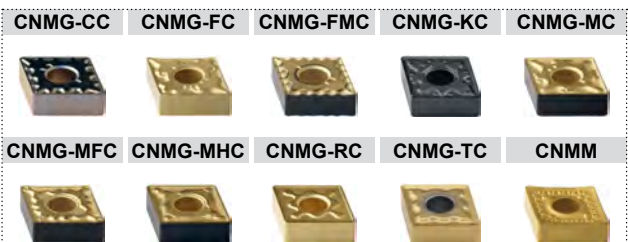
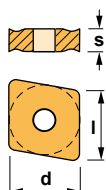



Characteristics:

Turning and profiling toolholder equipped with rhombic negative double-sided insert (angle 55°).

For low powered machines and small pieces choose toolholder Ref. SDJC (Page: A137).

Axial 6,25°
Radial -6,75°

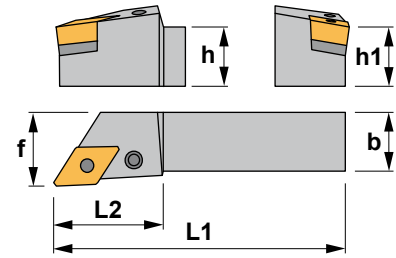

Eigenschaften:

Klemmhalter zum Profildrehen mit doppelseitigen rhombischen negativen Wendeschneidplatten (55° Winkel).

Für Niederleistungsmaschinen und kleine Werkstücke, wählen Sie Klemmhalter SDJC (Seite: A137).

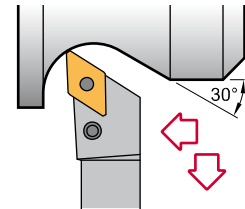

PDJN 93°

Reference Bezeichnung	h=h1	b	L1	L2	f	Insert size Wendeschneidplatte	kg
PDJN R/L 1616 H11	16	16	100	25	20	DN.. 1104..	0,250
PDJN R/L 2020 K11	20	20	125	28	25	DN.. 1104..	0,400
PDJN R/L 2525 M11	25	25	150	28	32	DN.. 1104..	0,750
PDJN R/L 3225 P11	32	25	170	28	32	DN.. 1104..	1,050
PDJN R/L 2020 K15	20	20	125	34	25	DN.. 1506..	0,400
PDJN R/L 2525 M15	25	25	150	34	32	DN.. 1506..	0,750
PDJN R/L 3225 P15	32	25	170	34	32	DN.. 1506..	1,050
PDJN R/L 3232 P15	32	32	170	34	40	DN.. 1506..	1,300
PDJN R/L 4025 R15	40	25	200	34	32	DN.. 1506..	1,850
PDJN R/L 5032 S15	50	32	250	34	40	DN.. 1506..	2,900

Reference Bezeichnung								Nm
PDJN R/L 1616 H11	8009	1606	5025	3711	4109	0009	- -	2.0
PDJN R/L 2020 K11	8009	1606	5025	3711	4109	0009	- -	2.0
PDJN R/L 2525 M11	8009	1606	5025	3711	4109	0009	- -	2.0
PDJN R/L 3225 P11	8009	1606	5025	3711	4109	0009	- -	2.0
PDJN R/L 2020 K15	8415	1638	5003	3715	4112	0012	3725 4135	3.0
PDJN R/L 2525 M15	8415	1638	5003	3715	4112	0012	3725 4135	3.0
PDJN R/L 3225 P15	8415	1638	5003	3715	4112	0012	3725 4135	3.0
PDJN R/L 3232 P15	8415	1638	5003	3715	4112	0012	3725 4135	3.0
PDJN R/L 4025 R15	8415	1638	5003	3715	4112	0012	3725 4135	3.0
PDJN R/L 5032 S15	8415	1638	5003	3715	4112	0012	3725 4135	3.0

For inserts DNM.. 1504
Für Wendeschneidplatten DNM.. 1504

DN.. 55° rhombic negative inserts. A36-37
55° rhombische negative Wendeschneidplatten.

Reference / Bez.	l	s	d
DN.. 1104..	11,60	4,76	9,52
DN.. 1504..	15,50	4,76	12,70
DN.. 1506..	15,50	6,35	12,70

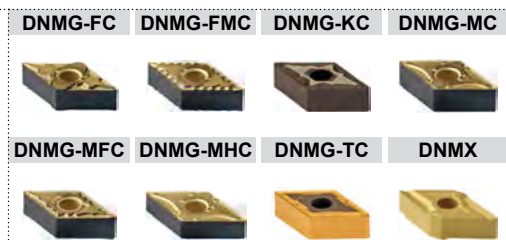
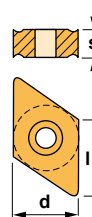



Characteristics:

Profiling toolholder equipped with rhombic negative double-sided insert (angle 55°).
For low powered machines and small pieces choose toolholder Ref. SDNC (Page: A140).

Axial -8°
Radial -2,5°

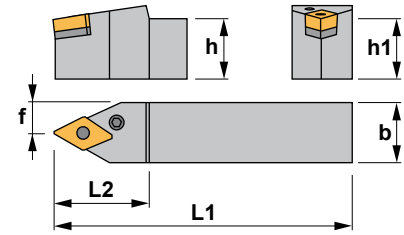

Eigenschaften:

Klemmhalter zum Profildrehen mit doppelseitigen rhombischen negativen Wendeschneidplatten (55° Winkel).

Für Niederleistungsmaschinen und kleine Werkstücke, wählen Sie Klemmhalter SDNC (Seite: A140).

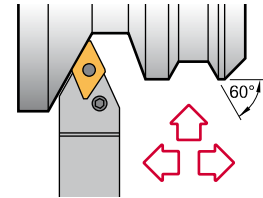

PDNN 63°

Reference Bezeichnung	h=h1	b	L1	L2	f	Insert size Wendeschneidplatte	Kg
PDNN R/L/N 2020 K15	20	20	125	34	10,0	DN.. 1506..	0,400
PDNN R/L/N 2525 M15	25	25	150	34	12,5	DN.. 1506..	0,750
PDNN R/L/N 3225 P15	32	25	170	34	12,5	DN.. 1506..	1,050
PDNN R/L/N 3232 P15	32	32	170	34	16,0	DN.. 1506..	1,300
PDNN R/L/N 4025 S15	40	25	250	34	12,5	DN.. 1506..	1,850
PDNN R/L/N 5032 S15	50	32	250	34	16,0	DN.. 1506..	2,900

Reference Bezeichnung									Nm
PDNN R/L/N 2020 K15	8415	1638	5003	3715	4112	0012	3725	4135	3.0
PDNN R/L/N 2525 M15	8415	1638	5003	3715	4112	0012	3725	4135	3.0
PDNN R/L/N 3225 P15	8415	1638	5003	3715	4112	0012	3725	4135	3.0
PDNN R/L/N 3232 P15	8415	1638	5003	3715	4112	0012	3725	4135	3.0
PDNN R/L/N 4025 S15	8415	1638	5003	3715	4112	0012	3725	4135	3.0
PDNN R/L/N 5032 S15	8415	1638	5003	3715	4112	0012	3725	4135	3.0

For inserts DNM.. 1504
Für Wendeschneidplatten DNM.. 1504

DN..		55° rhombic negative inserts. 55° rhombische negative Wendeschneidplatten. A36-37		
Reference / Bez.	l	s	d	
DN.. 1504..	15,50	4,76	12,70	
DN.. 1506..	15,50	6,35	12,70	

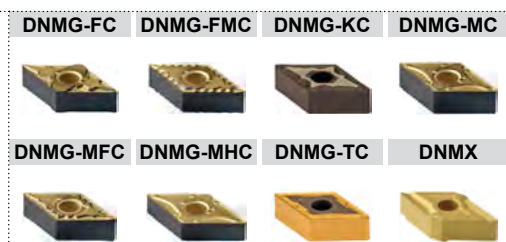
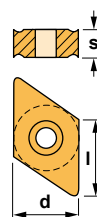

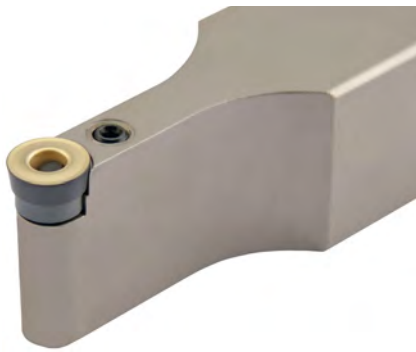

Characteristics:

Profiling toolholder equipped with round positive insert.

For screw type toolholders see Ref. SRDC (Page: A142).

Axial 0°
Radial 0°

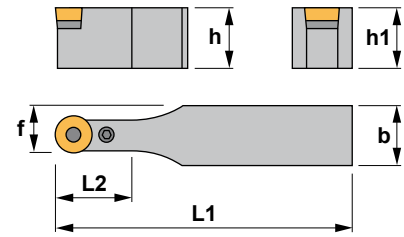

Eigenschaften:

Klemmhalter zum Profildrehen mit runden positiven Wendeschneidplatten.

Für Klemmhalter mit Schraubenklemmung, siehe SRDC (Seite: A142).

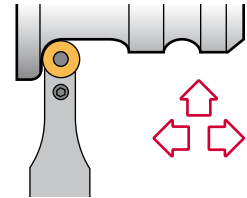

PRDC

Reference Bezeichnung	h=h1	b	L1	L2	f	Insert size Wendeschneidplatte	Kg
PRDC N 2020 K10	20	20	125	22	15,0	RC.. 1003M0	0,400
PRDC N 2525 M10	25	25	150	22	18,5	RC.. 1003M0	0,750
PRDC N 3225 P10	32	25	170	22	18,5	RC.. 1003M0	1,050
PRDC N 2020 K12	20	20	125	28	16,0	RC.. 1204M0	0,400
PRDC N 2525 M12	25	25	150	28	18,5	RC.. 1204M0	0,750
PRDC N 3225 P12	32	25	170	28	18,5	RC.. 1204M0	1,050
PRDC N 3232 P12	32	32	170	28	22,0	RC.. 1204M0	1,300
PRDC N 4025 S12	40	25	250	28	18,5	RC.. 1204M0	1,850
PRDC N 3225 P16	32	25	170	34	20,5	RC.. 1606M0	1,050
PRDC N 3232 P16	32	32	170	34	24,0	RC.. 1606M0	1,300
PRDC N 3232 P20	32	32	170	42	26,0	RC.. 2006M0	1,300
PRDC N 4040 S20	40	40	250	42	30,0	RC.. 2006M0	3,050
PRDC N 4040 S25	40	40	250	45	32,5	RC.. 2507M0	3,050
PRDC N 4040 U25	40	40	350	45	32,5	RC.. 2507M0	3,050
PRDC N 5050 U25	50	50	350	45	37,5	RC.. 2507M0	5,850
PRDC N 5050 V32	50	50	400	52	41,0	RC.. 3209M0	5,850

Reference Bezeichnung							Nm
PRDC N.....10	8110	1705	5002	3810	4110	0009	1.4
PRDC N.....12	8112	1606	5025	3812	4110	0009	2.0
PRDC N.....16	8116	1706	5025	3816	4116	0012	2.0
PRDC N.....20	8120	1708	5003	3820	4115	0015	3.0
PRDC N.....25	8125	1710	5004	3825	4119	0019	3.5
PRDC N.....32	8132	1612	5005	3832	4125	0025	4.0

RC..

Round positive inserts with 7° clearance. A38-39
Runde positive Wendeschneidplatten mit 7° Freiwinkel.

Reference / Bez.	s	d
RC.. 1003M0	3,18	10,00
RC.. 1204M0	4,76	12,00
RC.. 1606M0	6,35	16,00
RC.. 2006M0	6,35	20,00
RC.. 2507M0	7,94	25,00
RC.. 3209M0	9,52	32,00

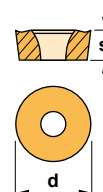

RCGT-AL



RCGT-AP



RCMT



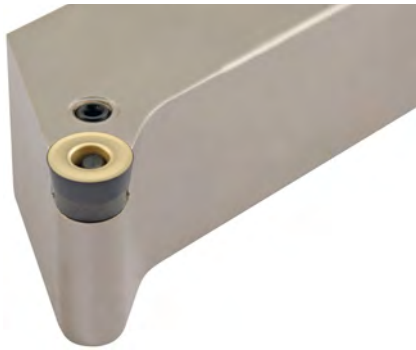

Characteristics:

Profiling multipurpose turning toolholder equipped with round positive insert.
For general applications, roughing, semi-finishing and finishing.

Axial 0°
Radial 0°

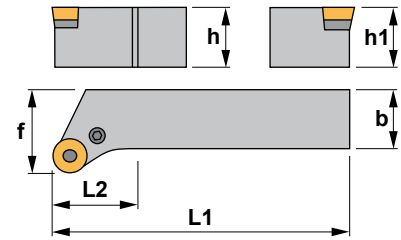

Eigenschaften:

Klemmhalter zum Profildrehen mit runden positiven Wendeschneidplatten.
Für allgemeine Anwendungen, Schruppen, Vorschlichten und Schlichten.

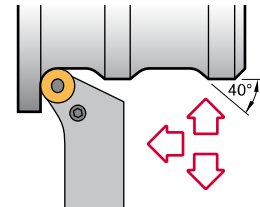

PRSC

Reference Bezeichnung	h=h1	b	L1	L2	f	Insert size Wendeschneidplatte	KG
PRSC R/L 2020 K10	20	20	125	28	25	RC.. 1003M0	0,400
PRSC R/L 2525 M10	25	25	150	28	32	RC.. 1003M0	0,750
PRSC R/L 3225 P10	32	25	170	28	32	RC.. 1003M0	1,050
PRSC R/L 2020 K12	20	20	125	28	25	RC.. 1204M0	0,400
PRSC R/L 2525 M12	25	25	150	28	32	RC.. 1204M0	0,750
PRSC R/L 3225 P12	32	25	170	28	32	RC.. 1204M0	1,050
PRSC R/L 2525 M16	25	25	150	34	32	RC.. 1606M0	0,750
PRSC R/L 3225 P16	32	25	170	34	32	RC.. 1606M0	1,050
PRSC R/L 3232 P20	32	32	170	42	40	RC.. 2006M0	1,300
PRSC R/L 4040 S20	40	40	250	48	50	RC.. 2006M0	3,050
PRSC R/L 4040 S25	40	40	250	48	50	RC.. 2507M0	3,050
PRSC R/L 5050 T32	50	50	300	50	60	RC.. 3209M0	5,850

Reference Bezeichnung							Nm
PRSC R/L 2020 K10	8110	1705	5002	3810	4110	0009	1.4
PRSC R/L 2525 M10	8110	1705	5002	3810	4110	0009	1.4
PRSC R/L 3225 P10	8110	1705	5002	3810	4110	0009	1.4
PRSC R/L 2020 K12	8112	1606	5025	3812	4110	0009	2.0
PRSC R/L 2525 M12	8112	1606	5025	3812	4110	0009	2.0
PRSC R/L 3225 P12	8112	1606	5025	3812	4110	0009	2.0
PRSC R/L 2525 M16	8116	1706	5025	3816	4116	0012	2.0
PRSC R/L 3225 P16	8116	1706	5025	3816	4116	0012	2.0
PRSC R/L 3232 P20	8120	1708	5003	3820	4115	0015	3.0
PRSC R/L 4040 S20	8120	1708	5003	3820	4115	0015	3.0
PRSC R/L 4040 S25	8125	1710	5004	3825	4119	0019	3.5
PRSC R/L 5050 T32	8132	1612	5005	3832	4125	0025	4.0

RC..

Round positive inserts with 7° clearance. A38-39
Runde positive Wendeschneidplatten mit 7° Freiwinkel.

Reference / Bez.	s	d
RC.. 1003M0	3,18	10,00
RC.. 1204M0	4,76	12,00
RC.. 1606M0	6,35	16,00
RC.. 2006M0	6,35	20,00
RC.. 2507M0	7,94	25,00
RC.. 3209M0	9,52	32,00

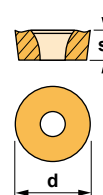

RCGT-AL



RCGT-AP



RCMT





Characteristics:

Profiling multipurpose turning toolholder equipped with round negative insert. For general applications, roughing, semi-finishing and finishing.

Axial -6°
Radial -6°

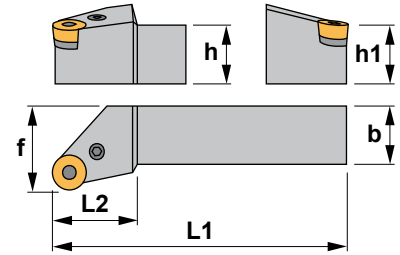

Eigenschaften:

Multifunktions-Klemmhalter zum Profildrehen mit runden negativen Wendeschneidplatten. Für allgemeine Anwendungen, Schruppen, Vorschlichten und Schlichten.

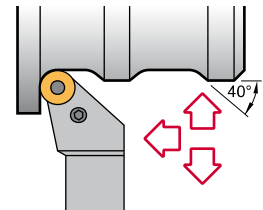

PRSN

Reference Bezeichnung	h=h1	b	L1	L2	f	Insert size Wendeschneidplatte	kg
PRSN R/L 2020 K09	20	20	125	22	25	RNMG 090300	0,400
PRSN R/L 2525 M12	25	25	150	28	32	RNMG 120400	0,750
PRSN R/L 3225 P15	32	25	170	34	32	RNMG 150600	1,050
PRSN R/L 3232 P19	32	32	170	42	40	RNMG 190600	1,300
PRSN R/L 4040 S25	40	40	250	45	50	RNMG 250900	3,050

Reference Bezeichnung							Nm
PRSN R/L 2020 K09	8009	1606	5025	3909	4110	0009	2.0
PRSN R/L 2525 M12	8012	1608	5003	3912	4112	0012	3.0
PRSN R/L 3225 P15	8015	1708	5003	3915	4115	0015	3.0
PRSN R/L 3232 P19	8019	1610	5004	3919	4119	0019	3.5
PRSN R/L 4040 S25	8025	1612	5005	3925	4125	0025	4.0

RNMG

Round negative inserts.
Runde negative Wendeschneidplatte. A39

Reference / Bez.

s

d

RNMG 090300

3,18

9,52

RNMG 120400

4,76

12,70

RNMG 150600

6,35

15,88

RNMG 190600

6,35

19,05

RNMG 250900

9,52

25,40

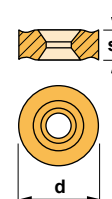

RNMG





Characteristics:

Toolholder for external turning applications equipped with square negative inserts.

For low powered machines and small pieces choose toolholder Ref. CSBP (Page: A116) or SSBC (Page: A143).

Axial -7,25°
Radial -4,25°

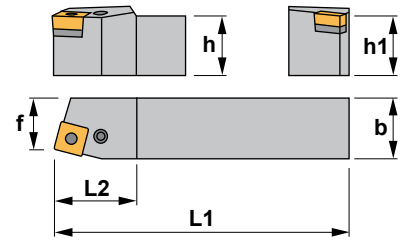

Eigenschaften:

Klemhalter zum Außendrehen mit vierkantigen negativen Wendeschneidplatten.

Für Niederleistungsmaschinen und kleine Werkstücke, wählen Sie Klemhalter Bez. CSBP (Seite: A116) oder SSBC (Seite: A143).

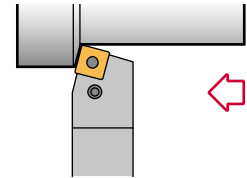

PSBN 75°

Reference Bezeichnung	h=h1	b	L1	L2	f	Insert size Wendeschneidplatte	Kg
PSBN R/L 1212 F09	12	12	80	18	11	SNM.. 0903..	0,100
PSBN R/L 1616 H09	16	16	100	22	13	SNM.. 0903..	0,250
PSBN R/L 2020 K09	20	20	125	22	17	SNM.. 0903..	0,400
PSBN R/L 2020 K12	20	20	125	28	17	SNM.. 1204..	0,400
PSBN R/L 2525 M12	25	25	150	28	22	SNM.. 1204..	0,750
PSBN R/L 3225 P12	32	25	170	28	22	SNM.. 1204..	1,050
PSBN R/L 2525 M15	25	25	150	34	22	SNM.. 1506..	0,750
PSBN R/L 3232 P15	32	32	170	34	27	SNM.. 1506..	1,300
PSBN R/L 3232 P19	32	32	170	42	27	SNM.. 1906..	1,300
PSBN R/L 4040 S19	40	40	250	48	35	SNM.. 1906..	3,050
PSBN R/L 5050 T19	50	50	300	50	43	SNM.. 1906..	3,050
PSBN R/L 4040 S25	40	40	250	48	35	SNM.. 2507..	3,050
PSBN R/L 5050 T25	50	50	300	50	43	SNM.. 2507..	5,850

Reference Bezeichnung							Nm
PSBN R/L 1212 F09	8005	1715	5002	-	-	-	1.4
PSBN R/L 1616 H09	8009	1606	5025	3509	4110	0009	2.0
PSBN R/L 2020 K09	8009	1606	5025	3509	4110	0009	2.0
PSBN R/L 2020 K12	8012	1608	5003	3512	4112	0012	3.0
PSBN R/L 2525 M12	8012	1608	5003	3512	4112	0012	3.0
PSBN R/L 3225 P12	8012	1608	5003	3512	4112	0012	3.0
PSBN R/L 2525 M15	8016	1618	5003	3515	4115	0015	3.0
PSBN R/L 3232 P15	8016	1618	5003	3515	4115	0015	3.0
PSBN R/L 3232 P19	8019	1610	5004	3519	4119	0019	3.5
PSBN R/L 4040 S19	8019	1610	5004	3519	4119	0019	3.5
PSBN R/L 5050 T19	8019	1610	5004	3519	4119	0019	3.5
PSBN R/L 4040 S25	8025	1612	5005	3525	4125	0025	4.0
PSBN R/L 5050 T25	8025	1612	5005	3525	4125	0025	4.0

SNM..

Square negative inserts.
Vierkantige negative Wendeschneidplatten. A41-42

Reference / Bez.	l	s	d
SNM.. 0903..	9,52	3,18	9,52
SNM.. 1204..	12,70	4,76	12,70
SNM.. 1506..	15,88	6,35	15,88
SNM.. 1906..	19,05	6,35	19,05
SNM.. 2507..	25,40	7,94	25,40

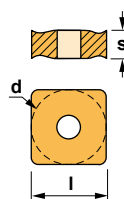

SNMG-FMC SNMG-KC SNMG-MHC



SNMG-RC SNMG-TC SNMM



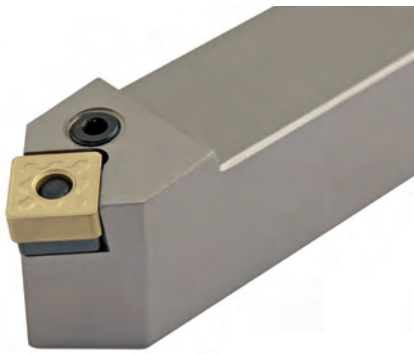

Characteristics:

Toolholder for external turning and chamfering applications equipped with square negative inserts. For low powered machines and small pieces choose toolholder Ref. CSDP (Page: A117) or SSSC (Page: A145).

Axial -7°
Radial 0°

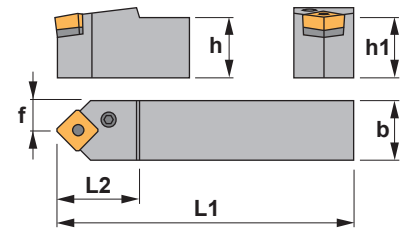

Eigenschaften:

Klemmhalter zum Außendrehen und Abschrägen mit vierkantigen negativen Wendschneidplatten. Für Niederleistungsmaschinen und kleine Werkstücke, wählen Sie Klemmhalter Bez. CSDP (Seite: A117) oder SSSC (Seite: A145).

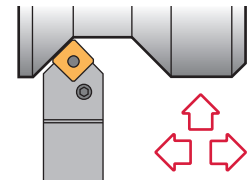

PSDN 45°

Reference Bezeichnung	h=h1	b	L1	L2	f	Insert size Wendschneidplatte	KG
PSDN N 1010 E09	10	10	70	16	5,0	SNM.. 0903..	0,070
PSDN N 1212 F09	12	12	80	20	6,0	SNM.. 0903..	0,100
PSDN N 1616 H09	16	16	100	22	8,0	SNM.. 0903..	0,250
PSDN N 2020 K12	20	20	125	28	10,0	SNM.. 1204..	0,400
PSDN N 2525 M12	25	25	150	28	12,5	SNM.. 1204..	0,750
PSDN N 3225 P12	32	25	170	34	12,5	SNM.. 1204..	1,050
PSDN N 3232 P12	32	32	170	34	16,0	SNM.. 1204..	1,300
PSDN N 3225 P19	32	25	170	34	12,5	SNM.. 1906..	1,050
PSDN N 3232 P19	32	32	170	42	16,0	SNM.. 1906..	1,300
PSDN N 4040 S19	40	40	250	48	20,0	SNM.. 1906..	3,050
PSDN N 4040 S25	40	40	250	48	20,0	SNM.. 2507..	3,050
PSDN N 5050 T25	50	50	300	50	25,0	SNM.. 2507..	5,850

Reference Bezeichnung							Nm
PSDN N 1010 E09	8005	1715	5002	-	-	-	1.4
PSDN N 1212 F09	8005	1715	5002	-	-	-	1.4
PSDN N 1616 H09	8009	1606	5025	3509	4110	0009	2.0
PSDN N 2020 K12	8012	1608	5003	3512	4112	0012	3.0
PSDN N 2525 M12	8012	1608	5003	3512	4112	0012	3.0
PSDN N 3225 P12	8012	1608	5003	3512	4112	0012	3.0
PSDN N 3232 P12	8012	1608	5003	3512	4112	0012	3.0
PSDN N 3225 P19	8019	1610	5004	3519	4119	0019	3.5
PSDN N 3232 P19	8019	1610	5004	3519	4119	0019	3.5
PSDN N 4040 S19	8025	1610	5004	3519	4119	0019	4.0
PSDN N 4040 S25	8025	1612	5005	3525	4125	0025	4.0
PSDN N 5050 T25	8025	1612	5005	3525	4125	0025	4.0

SNM..

Square negative inserts. Vierkantige negative Wendschneidplatten. A41-42

Reference / Bez.	l	s	d
SNM.. 0903..	9,52	3,18	9,52
SNM.. 1204..	12,70	4,76	12,70
SNM.. 1906..	19,05	6,35	19,05
SNM.. 2507..	25,40	7,94	25,40

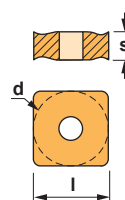

SNMG-FMC



SNMG-KC



SNMG-MHC



SNMG-RC



SNMG-TC



SNMM





Characteristics:

Toolholder for face turning applications equipped with square negative inserts.

For low powered machines and small pieces choose toolholder Ref. CSKP (Page: A118).

Axial -4,25°
Radial -7,25°

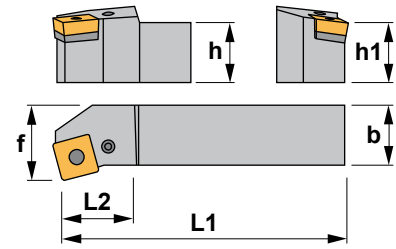

Eigenschaften:

Klemmhalter zum Plandrehen mit vierkantigen negativen Wendeschneidplatten.

Für Niederleistungsmaschinen und kleine Werkstücke, wählen Sie Klemmhalter Bez. CSKP (Seite: A118).

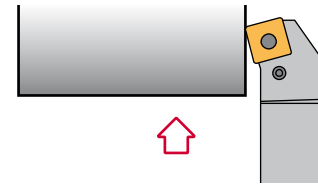

PSKN 75°

Reference Bezeichnung	h=h1	b	L1	L2	f	Insert size Wendeschneidplatte	KG
PSKN R/L 1616 H09	16	16	100	22	20	SNM.. 0903..	0,250
PSKN R/L 2020 K09	20	20	125	22	25	SNM.. 0903..	0,400
PSKN R/L 2020 K12	20	20	125	28	25	SNM.. 1204..	0,400
PSKN R/L 2525 M12	25	25	150	28	32	SNM.. 1204..	0,750
PSKN R/L 3225 P12	32	25	170	34	32	SNM.. 1204..	1,050
PSKN R/L 2525 M15	25	25	150	34	32	SNM.. 1506..	0,750
PSKN R/L 3232 P15	32	32	170	42	40	SNM.. 1506..	1,300
PSKN R/L 3232 P19	32	32	170	42	40	SNM.. 1906..	1,300
PSKN R/L 4040 S19	40	40	250	45	50	SNM.. 1906..	3,050
PSKN R/L 4040 S25	40	40	250	45	50	SNM.. 2507..	3,050
PSKN R/L 5050 T25	50	50	300	50	60	SNM.. 2507..	5,850

Reference Bezeichnung							Nm
PSKN R/L 1616 H09	8009	1606	5025	3509	4110	0009	2.0
PSKN R/L 2020 K09	8009	1606	5025	3509	4110	0009	2.0
PSKN R/L 2020 K12	8012	1608	5003	3512	4112	0012	3.0
PSKN R/L 2525 M12	8012	1608	5003	3512	4112	0012	3.0
PSKN R/L 3225 P12	8012	1608	5003	3512	4112	0012	3.0
PSKN R/L 2525 M15	8016	1618	5003	3515	4115	0015	3.0
PSKN R/L 3232 P15	8016	1618	5003	3515	4115	0015	3.0
PSKN R/L 3232 P19	8019	1610	5004	3519	4119	0019	3.5
PSKN R/L 4040 S19	8019	1610	5004	3519	4119	0019	3.5
PSKN R/L 4040 S25	8025	1612	5005	3525	4125	0025	4.0
PSKN R/L 5050 T25	8025	1612	5005	3525	4125	0025	4.0

SNM..

Square negative inserts.
Vierkantige negative Wendeschneidplatten. A41-42

Reference / Bez.	l	s	d
SNM.. 0903..	9,52	3,18	9,52
SNM.. 1204..	12,70	4,76	12,70
SNM.. 1506..	15,88	6,35	15,88
SNM.. 1906..	19,05	6,35	19,05
SNM.. 2507..	25,40	7,94	25,40

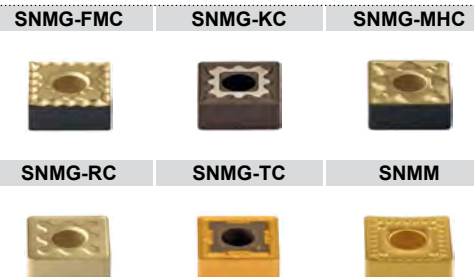
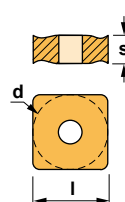

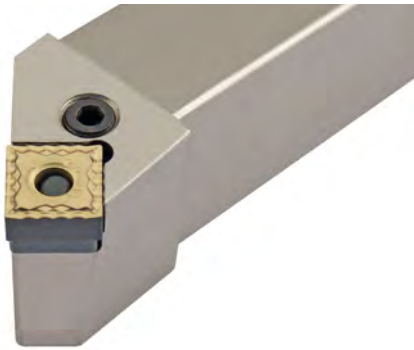

Characteristics: Toolholder for external turning and chamfering applications equipped with square negative inserts. For low powered machines and small pieces choose toolholder Ref. CSSP (Page: A119) or SSSC (Page: A145).

Axial -5,75°
Radial -5,75°

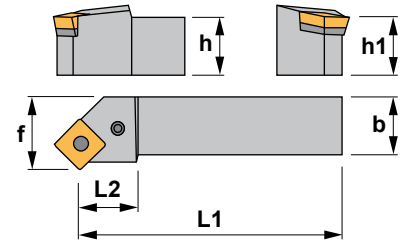

Eigenschaften: Klemmhalter zum Außendrehen und Abschrägen mit vierkantigen negativen Wendschneidplatten.

Für Niederleistungsmaschinen und kleine Werkstücke, wählen Sie Klemmhalter Bez. CSSP (Seite: A119) oder SSSC (Seite: A145).

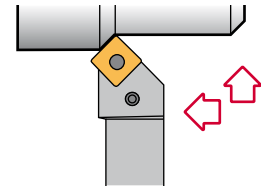

PSSN 45°

Reference Bezeichnung	h=h1	b	L1	L2	f	Insert size Wendschneidplatte	Kg
PSSN R/L 1616 H09	16	16	100	22	20	SNM.. 0903..	0,250
PSSN R/L 2020 K09	20	20	125	25	25	SNM.. 0903..	0,400
PSSN R/L 2020 K12	20	20	125	28	25	SNM.. 1204..	0,400
PSSN R/L 2525 M12	25	25	150	28	32	SNM.. 1204..	0,750
PSSN R/L 3225 P12	32	25	170	28	32	SNM.. 1204..	1,050
PSSN R/L 2525 M15	25	25	150	34	32	SNM.. 1506..	0,750
PSSN R/L 3225 P15	32	25	170	42	32	SNM.. 1506..	1,050
PSSN R/L 3232 P15	32	32	170	42	40	SNM.. 1506..	1,300
PSSN R/L 3232 P19	32	32	170	45	40	SNM.. 1906..	1,300
PSSN R/L 4040 S19	40	40	250	45	50	SNM.. 1906..	3,050
PSSN R/L 5050 T19	50	50	300	50	60	SNM.. 1906..	5,850
PSSN R/L 4040 S25	40	40	250	45	50	SNM.. 2507..	3,050
PSSN R/L 5050 T25	50	50	300	50	60	SNM.. 2507..	5,850

Reference Bezeichnung							Nm
PSSN R/L 1616 H09	8009	1606	5025	3509	4110	0009	2.0
PSSN R/L 2020 K09	8009	1606	5025	3509	4110	0009	2.0
PSSN R/L 2020 K12	8012	1608	5003	3512	4112	0012	3.0
PSSN R/L 2525 M12	8012	1608	5003	3512	4112	0012	3.0
PSSN R/L 3225 P12	8012	1608	5003	3512	4112	0012	3.0
PSSN R/L 2525 M15	8016	1618	5003	3515	4115	0015	3.0
PSSN R/L 3225 P15	8016	1618	5003	3515	4115	0015	3.0
PSSN R/L 3232 P15	8016	1618	5003	3515	4115	0015	3.0
PSSN R/L 3232 P19	8019	1610	5004	3519	4119	0019	3.5
PSSN R/L 4040 S19	8019	1610	5004	3519	4119	0019	3.5
PSSN R/L 5050 T19	8019	1610	5004	3519	4119	0019	3.5
PSSN R/L 4040 S25	8025	1612	5005	3525	4125	0025	4.0
PSSN R/L 5050 T25	8025	1612	5005	3525	4125	0025	4.0

SNM..

Square negative inserts.
Vierkantige negative Wendschneidplatten. A41-42

Reference / Bez.	l	s	d
SNM.. 0903..	9,52	3,18	9,52
SNM.. 1204..	12,70	4,76	12,70
SNM.. 1506..	15,88	6,35	15,88
SNM.. 1906..	19,05	6,35	19,05
SNM.. 2507..	25,40	7,94	25,40

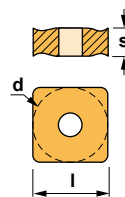

SNMG-FMC



SNMG-KC



SNMG-MHC



SNMG-RC



SNMG-TC



SNMM





Characteristics:

Toolholder for external turning and chamfering applications equipped with triangular negative inserts.

For low powered machines and small pieces choose toolholder Ref. CTD (Page: A124).

Axial -5°
Radial -5°

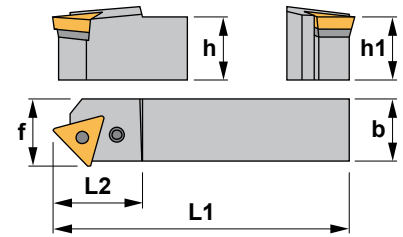

Eigenschaften:

Klemhalter zum Außendreien und Abschrägen mit dreikantigen negativen Wendeschneidplatten.

Für Niederleistungsmaschinen und kleine Werkstücke, wählen Sie Klemhalter Bez. CTD (Seite: A124).

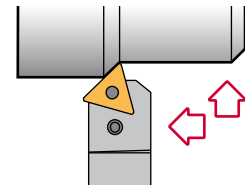

PTDN 45°

Reference Bezeichnung	h=h1	b	L1	L2	f	Insert size Wendeschneidplatte	KG
PTDN R/L 2525 M22	25	25	150	34	27	TNM.. 2204..	0,750
PTDN R/L 3225 P22	32	25	170	34	27	TNM.. 2204..	1,050

Reference Bezeichnung							Nm
PTDN R/L 2525 M22	8012	1608	5003	3422	4112	0012	3.0
PTDN R/L 3225 P22	8012	1608	5003	3422	4112	0012	3.0

TNM..				Triangular negative inserts. A45-46 Dreikantige negative Wendeschneidplatten.		
Reference / Bez.	l	s	d			
TNM.. 2204..	22,00	4,76	12,70			



Characteristics:

Toolholder for face turning applications equipped with triangular negative inserts. For low powered machines and small pieces choose toolholder Ref. CTFP (Page: A125) or STFC (Page: A148).

Axial -6°
Radial -6°

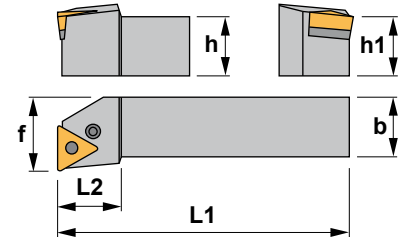

Eigenschaften:

Klemmhalter zum Plandrehen mit dreieckigen negativen Wendeschneidplatten.

Für Niederleistungsmaschinen und kleine Werkstücke, wählen Sie Klemmhalter Bez. CTFP (Seite: A125) oder STFC (Seite: A148).

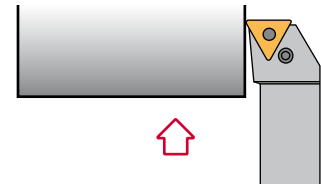

PTFN 90°

Reference Bezeichnung	h=h1	b	L1	L2	f	Insert size Wendeschneidplatte	
PTFN R/L 1616 H16	16	16	100	22	20	TNM.. 1604..	0,250
PTFN R/L 2020 K16	20	20	125	22	25	TNM.. 1604..	0,400
PTFN R/L 2525 M16	25	25	150	28	32	TNM.. 1604..	0,750
PTFN R/L 3225 P16	32	25	170	28	32	TNM.. 1604..	1,050
PTFN R/L 2525 M22	25	25	150	28	32	TNM.. 2204..	0,750
PTFN R/L 3225 P22	32	25	170	28	32	TNM.. 2204..	1,050
PTFN R/L 3232 P22	32	32	170	28	40	TNM.. 2204..	1,300
PTFN R/L 3232 P27	32	32	170	42	40	TNM.. 2706..	1,300
PTFN R/L 4040 S27	40	40	250	45	50	TNM.. 2706..	3,050

Reference Bezeichnung							Nm
PTFN R/L 1616 H16	8009	1606	5025	3416	4109	0009	2.0
PTFN R/L 2020 K16	8009	1606	5025	3416	4109	0009	2.0
PTFN R/L 2525 M16	8009	1606	5025	3416	4109	0009	2.0
PTFN R/L 3225 P16	8009	1606	5025	3416	4109	0009	2.0
PTFN R/L 2525 M22	8012	1608	5003	3422	4112	0012	3.0
PTFN R/L 3225 P22	8012	1608	5003	3422	4112	0012	3.0
PTFN R/L 3232 P22	8012	1608	5003	3422	4112	0012	3.0
PTFN R/L 3232 P27	8015	1708	5003	3427	4115	0015	3.0
PTFN R/L 4040 S27	8015	1708	5003	3427	4115	0015	3.0

TNM..

Triangular negative inserts.
Dreikantige negative WSP. A45-46

Reference / Bez.	l	s	d
TNM.. 1604..	16,50	4,76	9,52
TNM.. 2204..	22,00	4,76	12,70
TNM.. 2706..	27,50	6,35	15,88

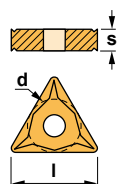



Characteristics:

Toolholder for external turning applications equipped with triangular negative inserts.
For low powered machines and small pieces choose toolholder Ref. CTGP (Page: A126) or STGC (Page: A149).

Axial -6°
Radial -6°

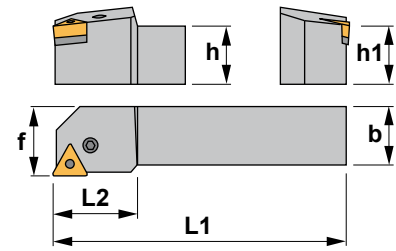

Eigenschaften:

Klemmhalter zum Außendrehen mit dreieckigen negativen Wendeschneidplatten.

Für Niederleistungsmaschinen und kleine Werkstücke, wählen Sie Klemmhalter Bez. CTGP (Seite: A126) oder STGC (Seite: A149).

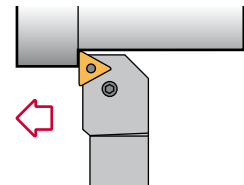

PTGN 90°

Reference Bezeichnung	h=h1	b	L1	L2	f	Insert size Wendeschneidplatte	⚖️
PTGN R/L 1616 H16	16	16	100	22	20	TNM.. 1604..	0,250
PTGN R/L 2020 K16	20	20	125	22	25	TNM.. 1604..	0,400
PTGN R/L 2525 M16	25	25	150	28	32	TNM.. 1604..	0,750
PTGN R/L 3225 P16	32	25	170	28	32	TNM.. 1604..	1,050
PTGN R/L 2525 M22	25	25	150	28	32	TNM.. 2204..	0,750
PTGN R/L 3225 P22	32	25	170	28	32	TNM.. 2204..	1,050
PTGN R/L 3232 P22	32	32	170	28	40	TNM.. 2204..	1,300
PTGN R/L 4040 S22	40	40	250	45	50	TNM.. 2204..	3,050
PTGN R/L 3232 P27	32	32	170	42	40	TNM.. 2706..	1,300
PTGN R/L 4040 S27	40	40	250	45	50	TNM.. 2706..	3,050
PTGN R/L 5050 T33	50	50	300	50	60	TNM.. 3307..	5,850

Reference Bezeichnung							Nm
PTGN R/L 1616 H16	8009	1606	5025	3416	4109	0009	2.0
PTGN R/L 2020 K16	8009	1606	5025	3416	4109	0009	2.0
PTGN R/L 2525 M16	8009	1606	5025	3416	4109	0009	2.0
PTGN R/L 3225 P16	8009	1606	5025	3416	4109	0009	2.0
PTGN R/L 2525 M22	8012	1608	5003	3422	4112	0012	3.0
PTGN R/L 3225 P22	8012	1608	5003	3422	4112	0012	3.0
PTGN R/L 3232 P22	8012	1608	5003	3422	4112	0012	3.0
PTGN R/L 4040 S22	8012	1608	5003	3422	4112	0012	3.0
PTGN R/L 3232 P27	8015	1708	5003	3427	4115	0015	3.0
PTGN R/L 4040 S27	8015	1708	5003	3427	4115	0015	3.0
PTGN R/L 5050 T33	8019	1610	5004	3433	4133	0019	3.5

TNM..

Triangular negative inserts.
Dreikantige negative WSP. **i** A45-46

Reference / Bez.	l	s	d
TNM.. 1604..	16,50	4,76	9,52
TNM.. 2204..	22,00	4,76	12,70
TNM.. 2706..	27,50	6,35	15,88
TNM.. 3307..	33,00	7,93	19,05

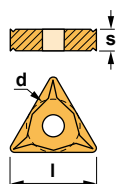



Characteristics: Toolholder for external turning and chamfering applications equipped with triangular negative inserts. For low powered machines and small pieces choose toolholder Ref. CTTT (Page: A127) or STTC (Page: A152).

Axial -8°
Radial -2,25°

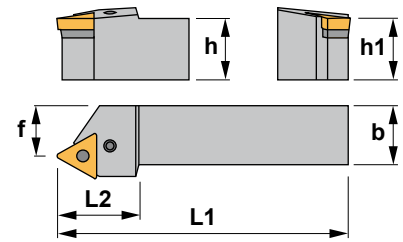

Eigenschaften:

Klemmhalter zum Außendrehen und Abschrägen mit dreieckigen negativen Wendeschneidplatten.
Für Niederleistungsmaschinen und kleine Werkstücke, wählen Sie Klemmhalter Bezeichnung CTTT (Seite: A127) oder STTC (Seite: A152).

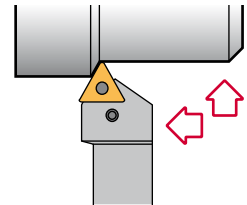

PTTN 60°

Reference Bezeichnung	h=h1	b	L1	L2	f	Insert size Wendeschneidplatte	Kg
PTTN R/L 1616 H16	16	16	100	25	13	TNM.. 1604..	0,250
PTTN R/L 2020 K16	20	20	125	28	17	TNM.. 1604..	0,400
PTTN R/L 2525 M16	25	25	150	28	22	TNM.. 1604..	0,750
PTTN R/L 2525 M22	25	25	150	34	22	TNM.. 2204..	0,750
PTTN R/L 3225 P22	32	25	170	34	22	TNM.. 2204..	1,050

Reference Bezeichnung							Nm
PTTN R/L 1616 H16	8009	1606	5025	3416	4109	0009	2.0
PTTN R/L 2020 K16	8009	1606	5025	3416	4109	0009	2.0
PTTN R/L 2525 M16	8009	1606	5025	3416	4109	0009	2.0
PTTN R/L 2525 M22	8012	1608	5003	3422	4112	0012	3.0
PTTN R/L 3225 P22	8012	1608	5003	3422	4112	0012	3.0

TNM..

Triangular negative inserts.
Dreikantige negative WSP. A45-46

Reference / Bez.	l	s	d
TNM.. 1604..	16,50	4,76	9,52
TNM.. 2204..	22,00	4,76	12,70

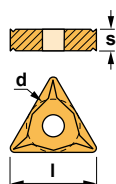



Characteristics:

Multipurpose toolholder equipped with trigon negative double-sided insert (angle 80°).
For top clamp toolholder see Ref. MWLN (Page: A92) or MWLN-K (Page: A93).

Axial -6°
Radial -6°

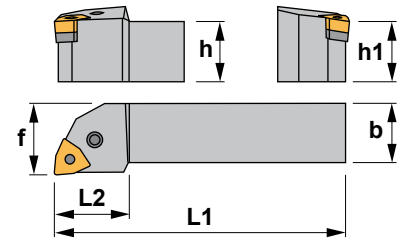

Eigenschaften:

Multifunktions-Klemmhalter mit doppelseitigen Trigon negativen Wendeschneidplatten (Winkel 80°).

Für Klemmhalter mit oberer Pratte siehe MWLN (Seite: A92) oder MWLN-K (Seite: A93).

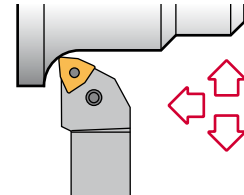

PWLN 95°

Reference Bezeichnung	h=h1	b	L1	L2	f	Insert size Wendeschneidplatte	
PWLN R/L 1616 H06	16	16	100	22	20	WNM.. 0604..	0,250
PWLN R/L 2020 K06	20	20	125	22	25	WNM.. 0604..	0,400
PWLN R/L 2525 M06	25	25	150	25	32	WNM.. 0604..	0,750
PWLN R/L 2020 K08	20	20	125	28	25	WNM.. 0804..	0,400
PWLN R/L 2525 M08	25	25	150	28	32	WNM.. 0804..	0,750
PWLN R/L 3225 P08	32	25	170	34	32	WNM.. 0804..	1,050
PWLN R/L 3232 P08	32	32	170	34	40	WNM.. 0804..	1,300

Reference Bezeichnung							Nm
PWLN R/L 1616 H06	8009	1606	5025	3007	4109	0009	2.0
PWLN R/L 2020 K06	8009	1606	5025	3007	4109	0009	2.0
PWLN R/L 2525 M06	8009	1606	5025	3007	4109	0009	2.0
PWLN R/L 2020 K08	8012	1608	5003	3008	4112	0012	3.0
PWLN R/L 2525 M08	8012	1608	5003	3008	4112	0012	3.0
PWLN R/L 3225 P08	8012	1608	5003	3008	4112	0012	3.0
PWLN R/L 3232 P08	8012	1608	5003	3008	4112	0012	3.0

WNMG

80° trigon negative inserts. A50-51
80° trigon negative Wendeschneidplatten.

Reference / Bez.	l	s	d
WNMG 0604..	6,45	4,76	9,52
WNMG 0804..	8,14	4,76	12,70

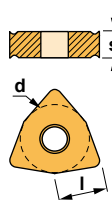



Characteristics:

Toolholder for turning and profiling operations equipped with KNUX negative insert.
For semi-finishing and finishing operations.

Axial 0°
Radial -6°

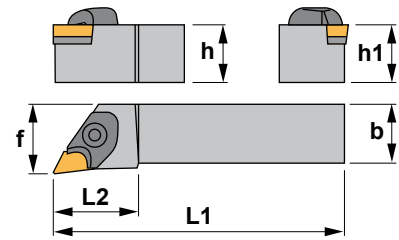

Eigenschaften:

Klemmhalter zum Plan- und Profildrehen mit negativen KNUX Wendeschneidplatten ausgerüstet, die wenig Schnittkraft erzeugen.
Zum Halbschlichten und Schlichten.

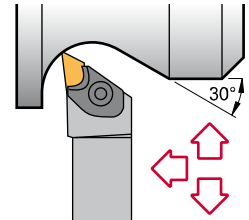

CKJN 93°

Reference Bezeichnung	h=h1	b	L1	L2	f	Insert size Wendeschneidplatte	Kg
CKJN R/L 2020 K16	20	20	125	34	30	KNUX 1604..	0,390
CKJN R/L 2525 M16	25	25	150	34	32	KNUX 1604..	0,700
CKJN R/L 3225 P16	32	25	170	34	32	KNUX 1604..	1,000
CKJN R/L 3232 P16	32	32	170	34	40	KNUX 1604..	1,250
CKJN R/L 4025 R16	40	25	200	38	32	KNUX 1604..	1,500

Reference Bezeichnung								Nm
CKJN R 2020 K16	2316	1614	5004	4295	4203	3226	4012	3.5
CKJN R 2525 M16	2316	1614	5004	4295	4204	3226	4012	3.5
CKJN R 3225 P16	2316	1614	5004	4295	4204	3226	4012	3.5
CKJN R 3232 P16	2316	1614	5004	4295	4204	3226	4012	3.5
CKJN R 4025 R16	2316	1614	5004	4295	4204	3226	4012	3.5
CKJN L 2020 K16	2326	1614	5004	4295	4203	3236	4012	3.5
CKJN L 2525 M16	2326	1614	5004	4295	4204	3236	4012	3.5
CKJN L 3225 P16	2326	1614	5004	4295	4204	3236	4012	3.5
CKJN L 3232 P16	2326	1614	5004	4295	4204	3236	4012	3.5
CKJN L 4025 R16	2326	1614	5004	4295	4204	3236	4012	3.5

KNUX

KNUX negative insert.
Negative KNUX Wendeschneidplatte. A38

Reference / Bezeichnung	l	s	d
KNUX 1604..	16,00	4,76	9,52

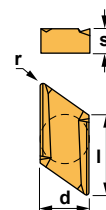

KNUX





Characteristics:

Toolholder for turning and profiling operations equipped with KNUX negative insert. For semi-finishing and finishing operations.

Axial $-2,75^\circ$
Radial $-5,25^\circ$

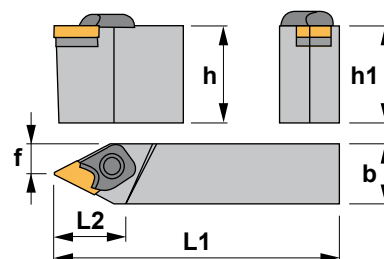

Eigenschaften:

Klemmhalter zum Plan- und Profildrehen mit negativen KNUX Wendeschneidplatten ausgerüstet, die wenig Schnittkraft erzeugen. Zum Halbschlichten und Schlichten.

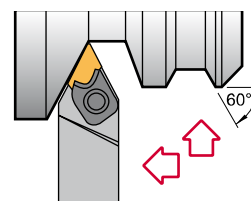

CKNN 63°

Reference Bezeichnung	h=h1	b	L1	L2	f	Insert size Wendeschneidplatte	
CKNN R/L 4025 R16	40	25	200	37	14,3	KNUX 1604..	1,500
CKNN R/L 5032 S16	50	32	250	37	16,8	KNUX 1604..	3,000

Reference Bezeichnung								Nm
CKNN R 4025 R16	2316	1614	5004	4295	4204	3226	4012	3.5
CKNN R 5032 S16	2316	1614	5004	4295	4204	3226	4012	3.5
CKNN L 4025 R16	2326	1614	5004	4295	4204	3236	4012	3.5
CKNN L 5032 S16	2326	1614	5004	4295	4204	3236	4012	3.5

KNUX

KNUX negative insert. A38
Negative KNUX Wendeschneidplatte.

Reference / Bezeichnung	l	s	d
KNUX 1604..	16,00	4,76	9,52

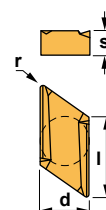

KNUX



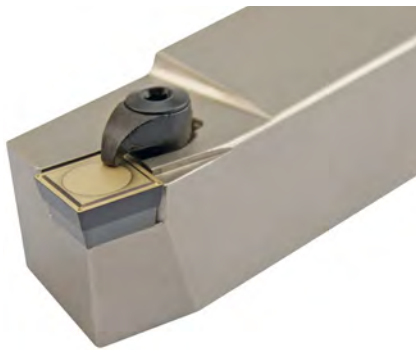

Characteristics:

Toolholder for external turning applications equipped with square positive inserts.
For all kind of materials. The workpiece should be stable.

Axial 1,50°
Radial 5,75°

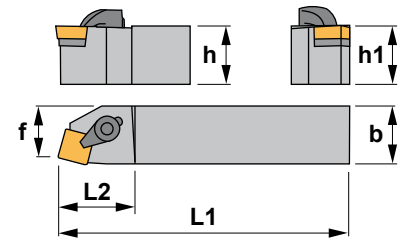

Eigenschaften:

Klemmhalter zum Außendrehen mit vierkantigen positiven Wendeschneidplatten.
Geeignet für alle Materialien. Das Werkstück muß stabil sein.

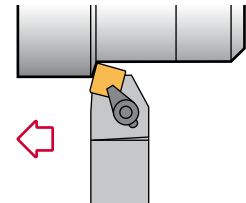

CSBP 75°

Reference Bezeichnung	h=h1	b	L1	L2	f	Insert size Wendeschneidplatte	KG
CSBP R/L 1212 F09	12	12	80	20	11	SP..0903..	0,070
CSBP R/L 1616 H09	16	16	100	22	13	SP..0903..	0,200
CSBP R/L 2020 K09	20	20	125	22	17	SP..0903..	0,400
CSBP R/L 2020 K12	20	20	125	34	17	SP..1203..	0,400
CSBP R/L 2525 M12	25	25	150	34	22	SP..1203..	0,700
CSBP R/L 3225 P12	32	25	170	34	22	SP..1203..	1,000
CSBP R/L 3232 P19	32	32	170	42	27	SP..1904..	1,250
CSBP R/L 4040 S19	40	40	250	48	35	SP..1904..	3,000
CSBP R/L 5050 T19	50	50	300	50	43	SP..1904..	5,650

Reference Bezeichnung					Nm
CSBP R/L 1212 F09	2207	5025	3109	4002	2.0
CSBP R/L 1616 H09	2207	5025	3109	4002	2.0
CSBP R/L 2020 K09	2207	5025	3109	4002	2.0
CSBP R/L 2020 K12	2209	5003	3112	4002	3.0
CSBP R/L 2525 M12	2209	5003	3112	4002	3.0
CSBP R/L 3225 P12	2209	5003	3112	4002	3.0
CSBP R/L 3232 P19	2211	5004	3119	4012	3.5
CSBP R/L 4040 S19	2211	5004	3119	4012	3.5
CSBP R/L 5050 T19	2211	5004	3119	4012	3.5

SP..

Square positive inserts with 11° clearance. A43
Vierkantige positive Wendeschneidplatten mit 11° Freiwinkel.

Reference / Bezeichnung	l	s	d
SP.. 0903..	9,52	3,18	9,52
SP.. 1203..	12,70	3,18	12,70
SP.. 1904..	19,05	4,76	19,05

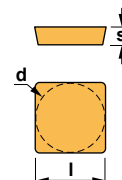

SPMR



SPUN



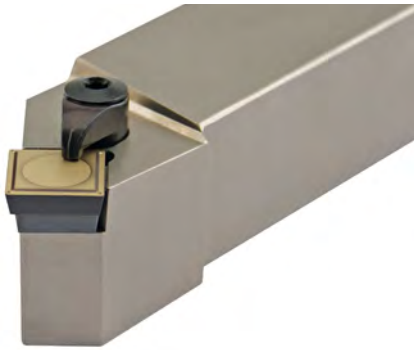

Characteristics:

Toolholder for external turning applications equipped with square positive inserts.
For interrupted cut choose toolholder Ref. PSDN (Page: A106).

Axial 4,25°
Radial 4,25°

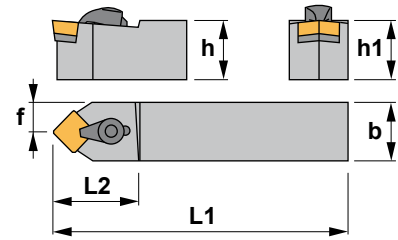

Eigenschaften:

Klemmhalter zum Außendreihen und Abschrägen mit vierkantigen positiven Wendeschneidplatten.

Für unterbrochenen Schnitt wählen Sie Klemmhalter PSDN (Seite: A106).

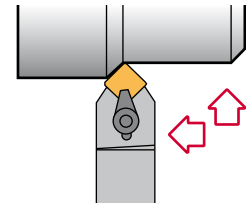

CSDP 45°

Reference Bezeichnung	h=h1	b	L1	L2	f	Insert size Wendeschneidplatte	kg
CSDP R/L 1010 E09	10	10	70	22	5,6	SP.. 0903..	0,030
CSDP R/L 1212 F09	12	12	80	22	7,6	SP.. 0903..	0,070
CSDP R/L 1616 H09	16	16	100	22	11,6	SP.. 0903..	0,200
CSDP R/L 2020 K12	20	20	125	28	14,0	SP.. 1203..	0,400
CSDP R/L 2525 M12	25	25	150	28	19,0	SP.. 1203..	0,700
CSDP N 1010 E09	10	10	70	22	5,0	SP.. 0903..	0,030
CSDP N 1212 F09	12	12	80	22	6,0	SP.. 0903..	0,070
CSDP N 1616 H09	16	16	100	22	8,0	SP.. 0903..	0,200
CSDP N 2020 K12	20	20	125	28	10,0	SP.. 1203..	0,400
CSDP N 2525 M12	25	25	150	28	12,5	SP.. 1203..	0,700

Reference Bezeichnung					Nm
CSDP R/L 1010 E09	2107	5025	-	-	2.0
CSDP R/L 1212 F09	2207	5025	3109	4002	2.0
CSDP R/L 1616 H09	2207	5025	3109	4002	2.0
CSDP R/L 2020 K12	2209	5003	3112	4002	3.0
CSDP R/L 2525 M12	2209	5003	3112	4002	3.0
CSDP N 1010 E09	2107	5025	-	-	2.0
CSDP N 1212 F09	2207	5025	3109	4002	2.0
CSDP N 1616 H09	2207	5025	3109	4002	2.0
CSDP N 2020 K12	2209	5003	3112	4002	3.0
CSDP N 2525 M12	2209	5003	3112	4002	3.0

SP..

Square positive inserts with 11° clearance. A43
Vierkantige positive Wendeschneidplatten mit 11° Freiwinkel.

Reference / Bezeichnung	l	s	d
SP.. 0903..	9,52	3,18	9,52
SP.. 1203..	12,70	3,18	12,70

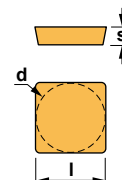

SPMR



SPUN





Characteristics:

Toolholder for face turning applications equipped with square positive inserts.
For interrupted cut choose toolholder Ref. PSKN (Page: A107).

Axial 5,75°
Radial 1,5°

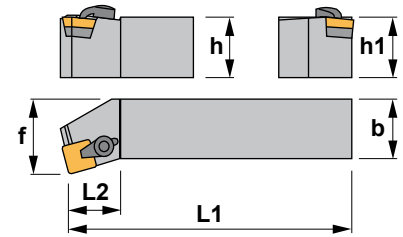

Eigenschaften:

Klemmhalter zum Plandrehen mit vierkantigen positiven Wendeschneidplatten.
Für unterbrochenen Schnitt wählen Sie Klemmhalter PSKN (Seite: A107).

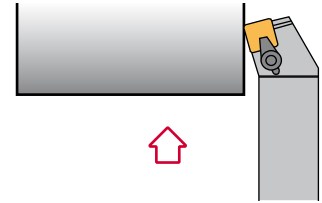

CSKP 75°

Reference Bezeichnung	h=h1	b	L1	L2	f	Insert size Wendeschneidplatte	Kg
CSKP R/L 1212 F09	12	12	80	18	16	SP..0903..	0,070
CSKP R/L 1616 H09	16	16	100	22	20	SP..0903..	0,200
CSKP R/L 2020 K09	20	20	125	25	25	SP..0903..	0,400
CSKP R/L 2020 K12	20	20	125	28	25	SP..1203..	0,400
CSKP R/L 2525 M12	25	25	150	28	32	SP..1203..	0,700
CSKP R/L 3225 P12	32	25	170	34	32	SP..1203..	1,000
CSKP R/L 3232 P19	32	32	170	42	40	SP..1904..	1,250
CSKP R/L 4040 S19	40	40	250	42	50	SP..1904..	3,000
CSKP R/L 5050 T19	50	50	300	50	60	SP..1904..	5,650

Reference Bezeichnung					Nm
CSKP R/L 1212 F09	2207	5025	3109	4002	2.0
CSKP R/L 1616 H09	2207	5025	3109	4002	2.0
CSKP R/L 2020 K09	2207	5025	3109	4002	2.0
CSKP R/L 2020 K12	2209	5003	3112	4002	3.0
CSKP R/L 2525 M12	2209	5003	3112	4002	3.0
CSKP R/L 3225 P12	2209	5003	3112	4002	3.0
CSKP R/L 3232 P19	2211	5004	3119	4012	3.5
CSKP R/L 4040 S19	2211	5004	3119	4012	3.5
CSKP R/L 5050 T19	2211	5004	3119	4012	3.5

SP..

Square positive inserts with 11° clearance. A43
Vierkantige positive Wendeschneidplatten mit 11° Freiwinkel.

Reference / Bezeichnung	l	s	d
SP.. 0903..	9,52	3,18	9,52
SP.. 1203..	12,70	3,18	12,70
SP.. 1904..	19,05	4,76	19,05

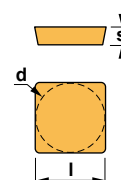

SPMR



SPUN





Characteristics:

Toolholder for external turning and chamfering applications equipped with square positive inserts.

For interrupted cut choose toolholder Ref. PSSN (Page: A108).

Axial 4,25°
Radial 4,25°

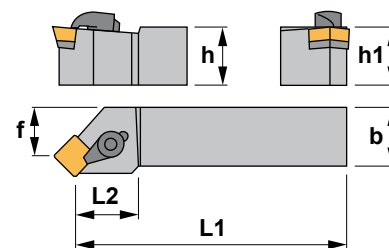

Eigenschaften:

Klemmhalter zum Außendreien und Abschrägen mit vierkantigen positiven Wendeschneidplatten.

Für unterbrochenen Schnitt wählen Sie Klemmhalter PSSN (Seite: A108).

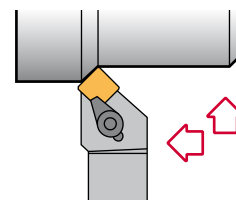

CSSP 45°

Reference Bezeichnung	h=h1	b	L1	L2	f	Insert size Wendeschneidplatte	Kg
CSSP R/L 1212 F09	12	12	80	20	16	SP.. 0903..	0,070
CSSP R/L 1616 H09	16	16	100	22	20	SP.. 0903..	0,200
CSSP R/L 2020 K12	20	20	125	25	25	SP.. 1203..	0,400
CSSP R/L 2525 M12	25	25	150	28	32	SP.. 1203..	0,700
CSSP R/L 3225 P12	32	25	170	28	32	SP.. 1203..	1,000
CSSP R/L 3232 P19	32	32	170	42	40	SP.. 1904..	1,250
CSSP R/L 4040 S19	40	40	250	42	50	SP.. 1904..	3,000

Reference Bezeichnung					Nm
CSSP R/L 1212 F09	2207	5025	3109	4002	2.0
CSSP R/L 1616 H09	2207	5025	3109	4002	2.0
CSSP R/L 2020 K12	2209	5003	3112	4002	3.0
CSSP R/L 2525 M12	2209	5003	3112	4002	3.0
CSSP R/L 3225 P12	2209	5003	3112	4002	3.0
CSSP R/L 3232 P19	2211	5004	3119	4012	3.5
CSSP R/L 4040 S19	2211	5004	3119	4012	3.5

SP..

Square positive inserts with 11° clearance. A43
Vierkantige positive Wendeschneidplatten mit 11° Freiwinkel.

Reference / Bezeichnung	l	s	d
SP.. 0903..	9,52	3,18	9,52
SP.. 1203..	12,70	3,18	12,70
SP.. 1904..	19,05	4,76	19,05

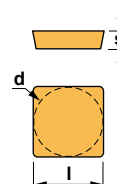

SPMR



SPUN





Characteristics:

Toolholder for external turning applications equipped with square positive inserts.
For interrupted cut choose toolholder Ref. PSBN (Page: A105).

Axial 3°
Radial 5,25°

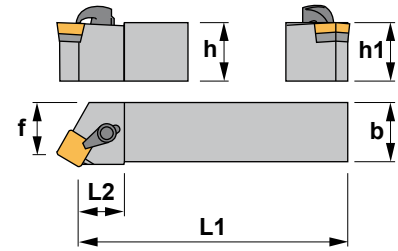

Eigenschaften:

Klemmhalter zum Außendreien mit vierkantigen positiven Wendeschneidplatten.
Für unterbrochenen Schnitt wählen Sie Klemmhalter PSBN (Seite: A105).

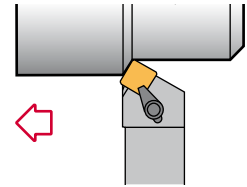

CSTP 60°

Reference Bezeichnung	h=h1	b	L1	L2	f	Insert size Wendeschneidplatte	kg
CSTP R/L 1616 H09	16	16	100	22	13	SP..0903..	0,200
CSTP R/L 2020 K09	20	20	125	28	17	SP..0903..	0,350
CSTP R/L 2020 K12	20	20	125	28	17	SP..1203..	0,400
CSTP R/L 2525 M12	25	25	150	28	22	SP..1203..	0,700

Reference Bezeichnung					Nm
CSTP R/L 1616 H09	2207	5025	3109	4002	2.0
CSTP R/L 2020 K09	2207	5025	3109	4002	2.0
CSTP R/L 2020 K12	2209	5003	3112	4002	3.0
CSTP R/L 2525 M12	2209	5003	3112	4002	3.0

SP..

Square positive inserts with 11° clearance. A43
Vierkantige positive Wendeschneidplatten mit 11° Freiwinkel.

Reference / Bezeichnung	l	s	d
SP.. 0903..	9,52	3,18	9,52
SP.. 1203..	12,70	3,18	12,70

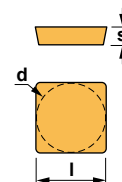

SPMR



SPUN



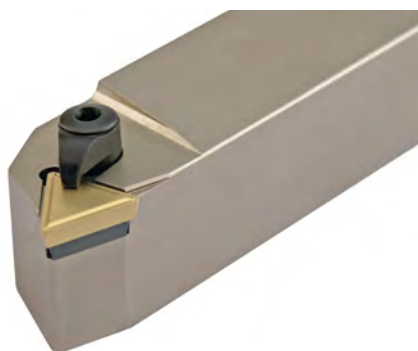

Characteristics:

Toolholder for external turning applications equipped with triangular positive inserts.

For all kind of materials. The workpiece should be stable.

Axial 1,5°
Radial 5,75°

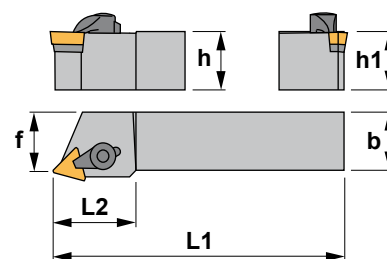

Eigenschaften:

Klemmhalter zum Außendreien mit dreikantigen positiven Wendeschneidplatten.

Geeignet für alle Materialien. Das Werkstück muß stabil sein.

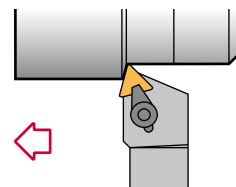

CTBP 75°

Reference Bezeichnung	h=h1	b	L1	L2	f	Insert size Wendeschneidplatte	kg
CTBP R/L 1212 F11	12	12	80	20	11	TP.. 1103..	0,070
CTBP R/L 1616 H11	16	16	100	22	13	TP.. 1103..	0,200
CTBP R/L 2020 K16	20	20	125	28	17	TP.. 1603..	0,400
CTBP R/L 2525 M16	25	25	150	28	22	TP.. 1603..	0,700

Reference Bezeichnung					Nm
CTBP R/L 1212 F11	2207	5025	-	-	2.0
CTBP R/L 1616 H11	2207	5025	-	-	2.0
CTBP R/L 2020 K16	2209	5003	3116	4002	3.0
CTBP R/L 2525 M16	2209	5003	3116	4002	3.0

TP.. Triangular positive inserts with 11° clearance. A47
Dreikantige positive Wendeschneidplatten mit 11° Freiwinkel.

Reference / Bez.	l	s	d
TP.. 1103..	11,00	3,18	6,35
TP.. 1603..	16,50	3,18	9,52

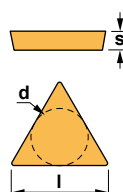



Characteristics:

Toolholder for face turning and grooving applications equipped with triangular positive inserts.

For all kind of materials. The workpiece should be stable.

Axial 6°
Radial 0°

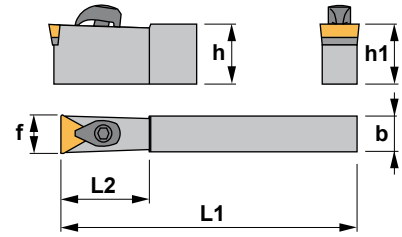

Eigenschaften:

Klemhalter zum Plandrehen und Einstechen mit dreikantigen positiven Wendeschneidplatten.

Geeignet für alle Materialien. Das Werkstück muß stabil sein.

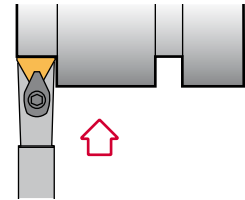

CTCPN 90°

Reference Bezeichnung	h=h1	b	L1	L2	f	Insert size Wendeschneidplatte	Kg
CTCP N 1009 E11	10	9	70	22	11	TP.. 1103..	0,040
CTCP N 2009 K11	20	9	125	22	11	TP.. 1103..	0,150
CTCP N 2509 R11	25	9	200	22	11	TP.. 1103..	0,350
CTCP N 2513 R16	25	13	200	28	16	TP.. 1603..	0,500
CTCP N 2518 R22	25	18	200	34	22	TP.. 2204..	0,650
CTCP N 4018 R22	40	18	200	34	22	TP.. 2204..	1,100

Reference Bezeichnung					Nm
CTCP N 1009 E11	2304	5025	-	-	2.0
CTCP N 2009 K11	2304	5025	-	-	2.0
CTCP N 2509 R11	2304	5025	-	-	2.0
CTCP N 2513 R16	2305	5003	3116	4002	3.0
CTCP N 2518 R22	2211	5004	3122	4012	3.5
CTCP N 4018 R22	2211	5004	3122	4012	3.5

TP.. Triangular positive inserts with 11° clearance. A47
Dreikantige positive Wendeschneidplatten mit 11° Freiwinkel.

Reference / Bez.	l	s	d
TP.. 1103..	11,00	3,18	6,35
TP.. 1603..	16,50	3,18	9,52
TP.. 2204..	22,00	4,76	12,70

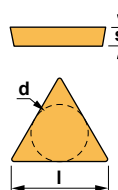



Characteristics:

Toolholder for face turning and grooving applications equipped with triangular positive inserts.

For all kind of materials. The workpiece should be stable.

Axial 6°
Radial 0°

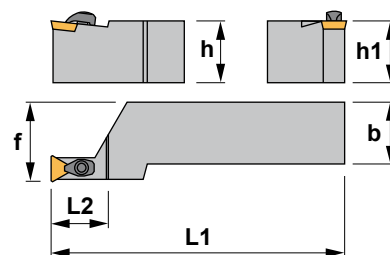

Eigenschaften:

Klemhalter zum Plandrehen und Einstechen mit dreikantigen positiven Wendeschneidplatten.

Geeignet für alle Materialien. Das Werkstück muß stabil sein.

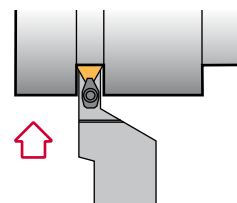

CTCP 90°

Reference Bezeichnung	h=h1	b	L1	L2	f	Insert size Wendeschneidplatte	Kg
CTCP R/L 1212 F11	12	12	80	22	16	TP.. 1103..	0,070
CTCP R/L 1616 H11	16	16	100	22	20	TP.. 1103..	0,200
CTCP R/L 2020 K11	20	20	125	22	25	TP.. 1103..	0,400
CTCP R/L 2525 M11	25	25	150	22	32	TP.. 1103..	0,700
CTCP R/L 3225 P16	32	25	170	28	32	TP.. 1603..	1,000
CTCP R/L 3232 P16	32	32	170	28	40	TP.. 1603..	1,250
CTCP R/L 3225 P22	32	25	170	34	32	TP.. 2204..	1,000
CTCP R/L 3232 P22	32	32	170	34	40	TP.. 2204..	1,250

Reference Bezeichnung					Nm
CTCP R/L 1212 F11	2304	5025	-	-	2.0
CTCP R/L 1616 H11	2304	5025	-	-	2.0
CTCP R/L 2020 K11	2304	5025	-	-	2.0
CTCP R/L 2525 M11	2304	5025	-	-	2.0
CTCP R/L 3225 P16	2305	5003	3116	4002	3.0
CTCP R/L 3232 P16	2305	5003	3116	4002	3.0
CTCP R/L 3225 P22	2211	5004	3122	4012	3.5
CTCP R/L 3232 P22	2211	5004	3122	4012	3.5

TP.. Triangular positive inserts with 11° clearance. A47
Dreikantige positive Wendeschneidplatten mit 11° Freiwinkel.

Reference / Bez.	l	s	d
TP.. 1103..	11,00	3,18	6,35
TP.. 1603..	16,50	3,18	9,52
TP.. 2204..	22,00	4,76	12,70

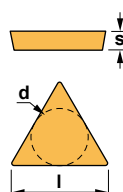



Characteristics:

Toolholder for external turning and chamfering turning applications equipped with triangular positive inserts. For interrupted cut choose toolholder Ref. PTDN (Page: A109).

Axial 4,25°
Radial 4,25°

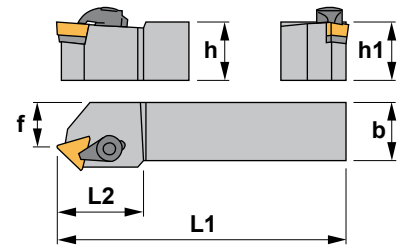

Eigenschaften:

Klemmhalter zum Außendreihen und Abschrägen mit dreikantigen positiven Wendeschneidplatten.

Für unterbrochenen Schnitt wählen Sie Klemmhalter PTDN (Seite: A109).

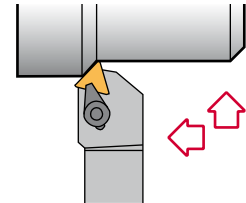

CTDP 45°

Reference Bezeichnung	h=h1	b	L1	L2	f	Insert size Wendeschneidplatte	Kg
CTDP R/L 1212 F11	12	12	80	20	6,3	TP.. 1103..	0,070
CTDP R/L 1616 H11	16	16	100	22	10,3	TP.. 1103..	0,200
CTDP R/L 2020 K16	20	20	125	28	12,2	TP.. 1603..	0,400
CTDP R/L 2525 M16	25	25	150	28	17,2	TP.. 1603..	0,700
CTDP R/L 3232 P16	32	32	170	28	23,5	TP.. 1603..	1,250
CTDP R/L 3232 P22	32	32	170	34	20,5	TP.. 2204..	1,250

Reference Bezeichnung						Nm
CTDP R/L 1212 F11	2207	5025	-	-	-	2.0
CTDP R/L 1616 H11	2207	5025	-	-	-	2.0
CTDP R/L 2020 K16	2209	5003	3116	4002	-	3.0
CTDP R/L 2525 M16	2209	5003	3116	4002	-	3.0
CTDP R/L 3232 P16	2209	5003	3116	4002	-	3.0
CTDP R/L 3232 P22	2211	5004	3122	4012	-	3.5

TP.. Triangular positive inserts with 11° clearance. A47
Dreikantige positive Wendeschneidplatten mit 11° Freiwinkel.

Reference / Bez.	l	s	d
TP.. 1103..	11,00	3,18	6,35
TP.. 1603..	16,50	3,18	9,52
TP.. 2204..	22,00	4,76	12,70

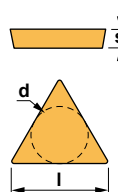



Characteristics:

Toolholder for face turning applications equipped with triangular positive inserts. For interrupted cut choose toolholder Ref. PTFN (Page: A110).

Axial 6°
Radial 0°

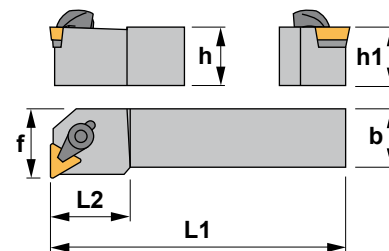

Eigenschaften:

Klemmhalter zum Plandrehen mit dreikantigen positiven Wendeschneidplatten. Für unterbrochenen Schnitt wählen Sie Klemmhalter PTFN (Seite: A110).



CTFP 90°

Reference Bezeichnung	h=h1	b	L1	L2	f	Insert size Wendeschneidplatte	KG
CTFP R/L 1010 E11	10	10	70	14	12	TP.. 1103..	0,030
CTFP R/L 1212 F11	12	12	80	20	16	TP.. 1103..	0,070
CTFP R/L 1616 H11	16	16	100	22	20	TP.. 1103..	0,200
CTFP R/L 2020 K11	20	20	125	22	25	TP.. 1103..	0,400
CTFP R/L 2020 K16	20	20	125	22	25	TP.. 1603..	0,400
CTFP R/L 2525 M16	25	25	150	25	32	TP.. 1603..	0,700
CTFP R/L 3225 P16	32	25	170	34	32	TP.. 1603..	1,000
CTFP R/L 3232 P16	32	32	170	34	40	TP.. 1603..	1,250
CTFP R/L 4040 S16	40	40	250	45	50	TP.. 1603..	3,000
CTFP R/L 5050 T16	50	50	300	50	60	TP.. 1603..	5,650
CTFP R/L 3232 P22	32	32	170	34	40	TP.. 2204..	1,250
CTFP R/L 4040 S22	40	40	250	45	50	TP.. 2204..	3,000
CTFP R/L 5050 T22	50	50	300	50	60	TP.. 2204..	5,650

Reference Bezeichnung					Nm
CTFP R/L 1010 E11	2000	5015	-	-	0.6
CTFP R/L 1212 F11	2207	5025	-	-	2.0
CTFP R/L 1616 H11	2207	5025	-	-	2.0
CTFP R/L 2020 K11	2207	5025	-	-	2.0
CTFP R/L 2020 K16	2209	5003	3116	4002	3.0
CTFP R/L 2525 M16	2209	5003	3116	4002	3.0
CTFP R/L 3225 P16	2209	5003	3116	4002	3.0
CTFP R/L 3232 P16	2209	5003	3116	4002	3.0
CTFP R/L 4040 S16	2209	5003	3116	4002	3.0
CTFP R/L 5050 T16	2209	5003	3116	4002	3.0
CTFP R/L 3232 P22	2211	5004	3122	4012	3.5
CTFP R/L 4040 S22	2211	5004	3122	4012	3.5
CTFP R/L 5050 T22	2211	5004	3122	4012	3.5

TP.. Triangular positive inserts with 11° clearance. A47
Dreikantige positive Wendeschneidplatten mit 11° Freiwinkel.

Reference / Bez.	l	s	d
TP.. 1103..	11,00	3,18	6,35
TP.. 1603..	16,50	3,18	9,52
TP.. 2204..	22,00	4,76	12,70

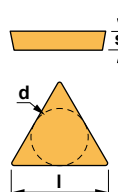



Characteristics:

Toolholder for external turning applications equipped with triangular positive inserts. For interrupted cut choose toolholder Ref. PTGN (Page: A111).

Axial 0°
Radial 6°

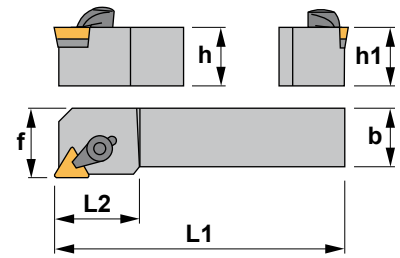

Eigenschaften:

Klemmhalter zum Außendrehen mit dreieckigen positiven Wendeschneidplatten. Für unterbrochenen Schnitt wählen Sie Klemmhalter PTGN (Seite: A111).

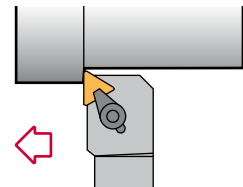

CTGP 90°

Reference Bezeichnung	h=h1	b	L1	L2	f	Insert size Wendeschneidplatte	Kg
CTGP R/L 1010 E11	10	10	70	16	12	TP.. 1103..	0,030
CTGP R/L 1212 F11	12	12	80	18	16	TP.. 1103..	0,070
CTGP R/L 1616 H11	16	16	100	18	20	TP.. 1103..	0,200
CTGP R/L 2020 K11	20	20	125	22	25	TP.. 1103..	0,400
CTGP R/L 2020 K16	20	20	125	28	25	TP.. 1603..	0,400
CTGP R/L 2525 M16	25	25	150	28	32	TP.. 1603..	0,700
CTGP R/L 3225 P16	32	25	170	34	32	TP.. 2204..	1,000
CTGP R/L 3232 P22	32	32	170	34	40	TP.. 2204..	1,250
CTGP R/L 4040 S22	40	40	250	45	50	TP.. 2204..	3,000
CTGP R/L 5050 T22	50	50	300	50	60	TP.. 2204..	5,650

Reference Bezeichnung					Nm
CTGP R/L 1010 E11	2000	5015	-	-	0.6
CTGP R/L 1212 F11	2207	5025	-	-	2.0
CTGP R/L 1616 H11	2207	5025	-	-	2.0
CTGP R/L 2020 K11	2207	5025	-	-	2.0
CTGP R/L 2020 K16	2209	5003	3116	4002	3.0
CTGP R/L 2525 M16	2209	5003	3116	4002	3.0
CTGP R/L 3225 P16	2209	5003	3116	4002	3.0
CTGP R/L 3232 P22	2211	5004	3122	4012	3.5
CTGP R/L 4040 S22	2211	5004	3122	4012	3.5
CTGP R/L 5050 T22	2211	5004	3122	4012	3.5

TP.. Triangular positive inserts with 11° clearance. A47
Dreieckige positive Wendeschneidplatten mit 11° Freiwinkel.

Reference / Bez.	l	s	d
TP.. 1103..	11,00	3,18	6,35
TP.. 1603..	16,50	3,18	9,52
TP.. 2204..	22,00	4,76	12,70

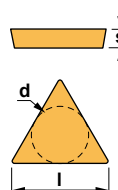

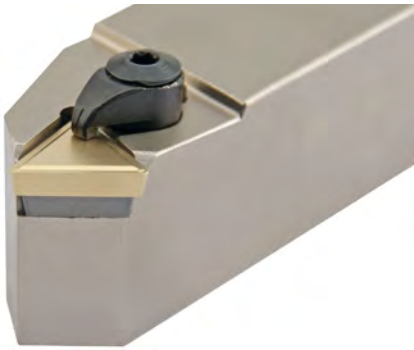

Characteristics:

Toolholder for external turning and chamfering turning applications equipped with triangular positive inserts.

For interrupted cut choose toolholder Ref. PTTN (Page: A112).

Axial 3°
Radial 5,25°

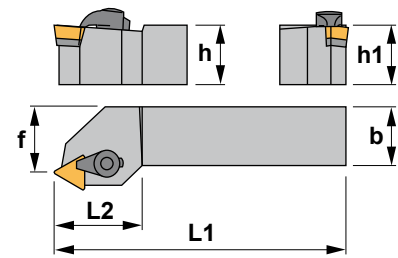

Eigenschaften:

Klemmhalter zum Außendrehen und Abschrägen mit dreikantigen positiven Wendeschneidplatten.

Für unterbrochenen Schnitt wählen Sie Klemmhalter PTTN (Seite: A112).

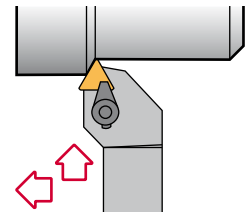

CTTP 60°

Reference Bezeichnung	h=h1	b	L1	L2	f	Insert size Wendeschneidplatte	Kg
CTTP R/L 0808 D09	8	8	60	16	7	TP.. 0902..	0,020
CTTP R/L 1010 E09	10	10	70	16	9	TP.. 0902..	0,030
CTTP R/L 1010 E11	10	10	70	16	9	TP.. 1103..	0,030
CTTP R/L 1212 F11	12	12	80	20	11	TP.. 1103..	0,070
CTTP R/L 1616 H11	16	16	100	22	13	TP.. 1103..	0,200
CTTP R/L 2020 K11	20	20	125	22	17	TP.. 1103..	0,400
CTTP R/L 2020 K16	20	20	125	28	17	TP.. 1603..	0,400
CTTP R/L 2525 M16	25	25	150	28	22	TP.. 1603..	0,700

Reference Bezeichnung					Nm
CTTP R/L 0808 D09	2000	5015	-	-	0.6
CTTP R/L 1010 E09	2000	5015	-	-	0.6
CTTP R/L 1010 E11	2000	5015	-	-	0.6
CTTP R/L 1212 F11	2207	5025	-	-	2.0
CTTP R/L 1616 H11	2207	5025	-	-	2.0
CTTP R/L 2020 K11	2207	5025	-	-	2.0
CTTP R/L 2020 K16	2209	5003	3116	4002	3.0
CTTP R/L 2525 M16	2209	5003	3116	4002	3.0

TP.. Triangular positive inserts with 11° clearance. A47
Dreikantige positive Wendeschneidplatten mit 11° Freiwinkel.

Reference / Bez.	l	s	d
TP.. 0902..	9,62	2,38	5,55
TP.. 1103..	11,00	3,18	6,35
TP.. 1603..	16,50	3,18	9,52

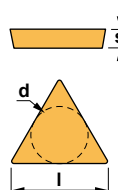

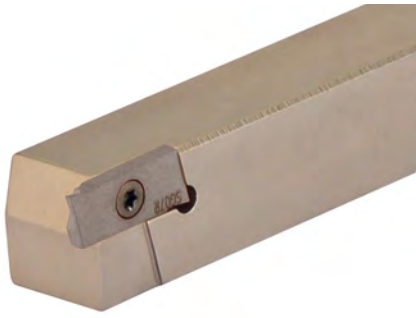

Characteristics:
Multipurpose mini-toolholders for grooving, threading and turning. For precision turning.

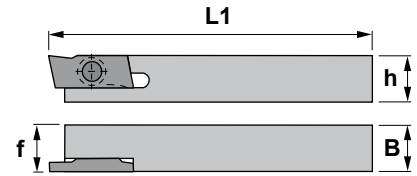

Eigenschaften:
Multifunktions-Mini-Klemmhalter zum Nuteinstecken, Gewindedrehen und Drehen. Zum Präzisionsdrehen.

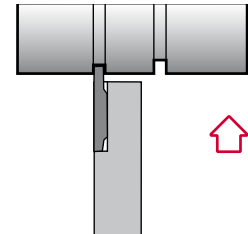

STHE

Reference Bezeichnung	h	h1	B	L	f	Insert size Wendschneidplatte	kg
STHER/L0808M07	8	8	8	150	8	GI..	0,070
STHER/L1010M07	10	10	10	150	10	GI..	0,110
STHER/L1212M07	12	12	12	150	12	GI..	0,150
STHER/L1616M07	16	16	16	150	16	GI..	0,280

Reference Bezeichnung			Nm
STHER/L0808M07	1230	5508	1.2
STHER/L1010M07	1230	5508	1.2
STHER/L1212M07	1230	5508	1.2
STHER/L1616M07	1230	5508	1.2

GI

B06

Reference / Bez.	l	s	d
GI..	17,00	2,00	7,00

GIGP - Grooving and cut-off inserts
GIGW - Threading inserts
GISG - Grooving inserts
GIST - Turning inserts

GIGP - Ein- und Abstechplatten
GIGW - Gewindedrehplatten
GISG - Stechdrehplatten
GIST - Drehplatten

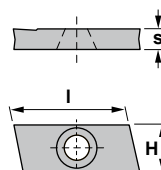

GIGP

GIGW



GISG

GIST





Characteristics:
Toolholder for turning convex radius on internal and external diameters in manual machines.

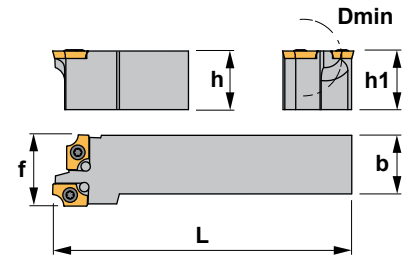

Eigenschaften:
Werkzeug um konvexen Radien in Innen- und Aussendurchmessern bei manuellen Maschinen zu drehen.

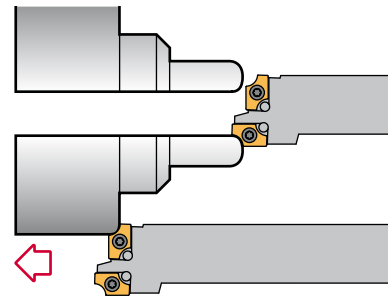

SAGD 90°

Reference Bezeichnung	h=h1	b	L	f	Dmin	Insert size Wendeschneidplatte	KG
SAGD R 1616 H15	16	16	100	30	20	ADMT 1503..	0,260
SAGD R 2020 K15	20	20	125	30	20	ADMT 1503..	0,450
SAGD R 2525 M15	25	25	150	30	20	ADMT 1503..	0,650

Reference Bezeichnung			Nm
SAGD R 1616 H15	1240	5515	3.0
SAGD R 2020 K15	1240	5515	3.0
SAGD R 2525 M15	1240	5515	3.0

ADMT-R

Parallelogram positive inserts with 15° clearance. A30
Parallelogramme positive WSP mit 15° Freiwinkel.

Reference / Bezeichnung	r	s	d
ADMT 1503R1.0	1.0	3,18	9,52
ADMT 1503R1.5	1.5	3,18	9,52
ADMT 1503R2.0	2.0	3,18	9,52
ADMT 1503R2.5	2.5	3,18	9,52
ADMT 1503R3.0	3.0	3,18	9,52
ADMT 1503R3.5	3.5	3,18	9,52
ADMT 1503R4.0	4.0	3,18	9,52
ADMT 1503R4.5	4.5	3,18	9,52
ADMT 1503R5.0	5.0	3,18	9,52

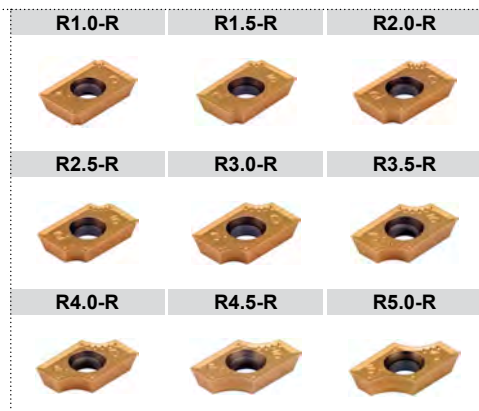
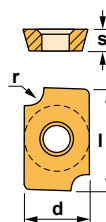

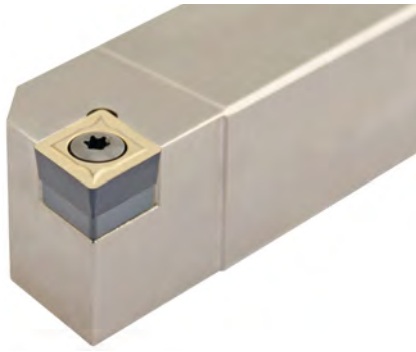

Characteristics:

Toolholder for external turning applications equipped with rhombic positive inserts (angle 80°).

For all kind of materials. The workpiece should be stable.

Axial 0°
Radial 0°

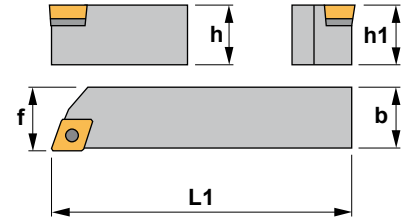

Eigenschaften:

Klemmhalter zum Außendreihen mit rhombischen positiven Wendeschneidplatten (80° Winkel). Geeignet für alle Materialien. Das Werkstück muß stabil sein.

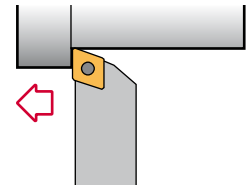

SCAC 90°

Reference Bezeichnung	h=h1	b	L1	f	Insert size Wendeschneidplatte	Kg
SCAC R/L 0808 D06	8	8	60	8,5	CC.. 0602..	0,050
SCAC R/L 1010 E06	10	10	70	10,5	CC.. 0602..	0,070
SCAC R/L 1212 F09	12	12	80	12,5	CC.. 09T3..	0,100
SCAC R/L 1616 H09	16	16	100	16,5	CC.. 09T3..	0,200
SCAC R/L 2020 K12	20	20	125	20,5	CC.. 1204..	0,400
SCAC R/L 2525 M12	25	25	150	25,5	CC.. 1204..	0,700

Reference Bezeichnung					Nm
SCAC R/L 0808 D06	1225	5507	-	-	0.9
SCAC R/L 1010 E06	1225	5507	-	-	0.9
SCAC R/L 1212 F09	1240	5515	-	-	3.0
SCAC R/L 1616 H09	1240	5515	-	-	3.0
SCAC R/L 2020 K12	1540	5517	3614	1760	3.0
SCAC R/L 2525 M12	1540	5517	3614	1760	3.0

CC.. 80° rhombic positive inserts with 7° clearance. A30-31
80° rhombische positive Wendeschneidplatten mit 7° Freiwinkel.

Reference / Bez.	l	s	d
CC.. 0602..	6,45	2,38	6,35
CC.. 09T3..	9,65	3,97	9,52
CC.. 1204..	12,90	4,76	12,70

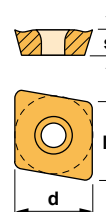

CCGT-AL



CCGT-AP



CCMT



CCMW



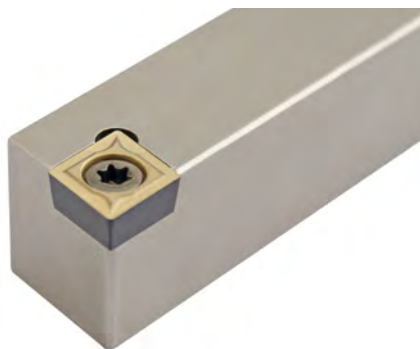

Characteristics:
Toolholder for external turning applications equipped with rhombic positive inserts (angle 80°).
For all kind of materials. The workpiece should be stable.

Axial 0°
Radial 0°

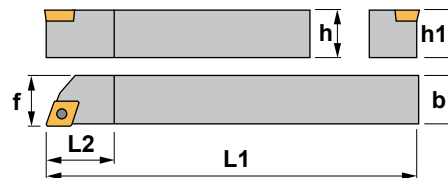

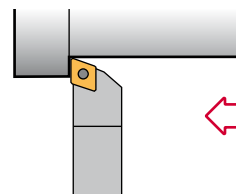

Eigenschaften:
Klemmhalter zum Drehen mit rhombischen positiven Wendeschneidplatten (80° Winkel). Für alle Materialien geeignet. Das Werkstück sollte stabil sein.



SCAC 90° Automatic lathes Drehautomaten

Reference Bezeichnung	h=h1	b	L1	L2	f	Insert size Wendeschneidplatte	
SCAC R/L 0808 M06	8	8	150	8	8	CC.. 0602..	0,070
SCAC R/L 1010 M06	10	10	150	10	10	CC.. 0602..	0,110
SCAC R/L 1212 M06	12	12	150	12	12	CC.. 0602..	0,150
SCAC R/L 1616 M06	16	16	150	16	16	CC.. 0602..	0,280
SCAC R/L 1212 M09	12	12	150	12	12	CC.. 09T3..	0,150
SCAC R/L 1616 M09	16	16	150	16	16	CC.. 09T3..	0,280

Reference Bezeichnung			Nm
SCAC R/L 0808 M06	1225	5507	0.9
SCAC R/L 1010 M06	1225	5507	0.9
SCAC R/L 1212 M06	1225	5507	0.9
SCAC R/L 1616 M06	1225	5507	0.9
SCAC R/L 1212 M09	1240	5515	3.0
SCAC R/L 1616 M09	1240	5515	3.0

CC.. 80° rhombic positive inserts with 7° clearance.  A30-31
80° rhombische positive Wendeschneidplatten mit 7° Freiwinkel.

Reference / Bez.	l	s	d
CC.. 0602..	6,45	2,38	6,35
CC.. 09T3..	9,65	3,97	9,52

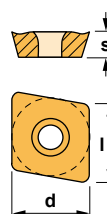

CCGT-AL



CCGT-AP



CCMT



CCMW



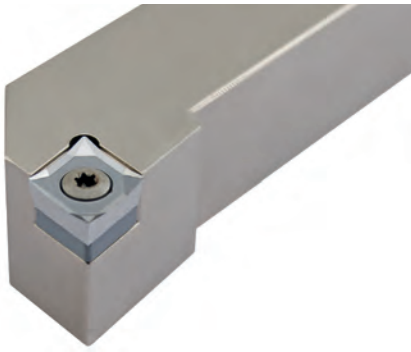

Characteristics:

Multipurpose toolholder equipped with rhombic positive insert (angle 80°).

For toolholders with negative inserts see Ref. MCLN-K (Page: A81) or MCLN (Page: A80) or PCLN (Page: A97).

Axial 0°
Radial 0°

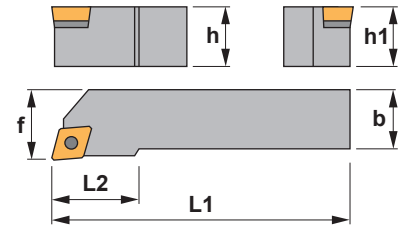

Eigenschaften: Multifunktions-Klemmhalter mit rhombischen positiven Wendeschneidplatten (80° Winkel).

Für Klemmhalter mit negativen Wendeschneidplatten, siehe MCLN-K (Seite: A81) oder MCLN (Seite: A80) oder PCLN (Seite: A97).

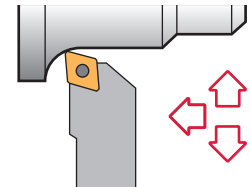

SCLC 95°

Reference Bezeichnung	h=h1	b	L1	L2	f	Insert size Wendeschneidplatte	Kg
SCLC R/L 0808 D06	8	8	60	12	10	CC.. 0602..	0,050
SCLC R/L 1010 E06	10	10	70	14	12	CC.. 0602..	0,070
SCLC R/L 1212 F09	12	12	80	16	16	CC.. 09T3..	0,100
SCLC R/L 1616 H09	16	16	100	18	20	CC.. 09T3..	0,200
SCLC R/L 2020 K09	20	20	125	22	25	CC.. 09T3..	0,400
SCLC R/L 2525 M09	25	25	150	28	32	CC.. 09T3..	0,700
SCLC R/L 1616 H12	16	16	100	18	20	CC.. 1204..	0,200
SCLC R/L 2020 K12	20	20	125	22	25	CC.. 1204..	0,400
SCLC R/L 2525 M12	25	25	150	28	32	CC.. 1204..	0,700

Reference Bezeichnung					Nm
SCLC R/L 0808 D06	1225	5507	-	-	0.9
SCLC R/L 1010 E06	1225	5507	-	-	0.9
SCLC R/L 1212 F09	1240	5515	-	-	3.0
SCLC R/L 1616 H09	1240	5515	-	-	3.0
SCLC R/L 2020 K09	1240	5515	-	-	3.0
SCLC R/L 2525 M09	1240	5515	-	-	3.0
SCLC R/L 1616 H12	1540	5517	3614	1760	3.0
SCLC R/L 2020 K12	1540	5517	3614	1760	3.0
SCLC R/L 2525 M12	1540	5517	3614	1760	3.0

CC.. 80° rhombic positive inserts with 7° clearance. A30-31
80° rhombische positive Wendeschneidplatten mit 7° Freiwinkel.

Reference / Bez.	l	s	d
CC.. 0602..	6,45	2,38	6,35
CC.. 09T3..	9,65	3,97	9,52
CC.. 1204..	12,90	4,76	12,70

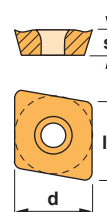

CCGT-AL



CCGT-AP



CCMT



CCMW





Characteristics:

Multipurpose toolholder equipped with rhombic positive insert (angle 80°).

For toolholders with negative inserts see Ref. MCLN-K (Page: A81) or MCLN (Page: A80) or PCLN (Page: A97).

Axial 0°
Radial 0°

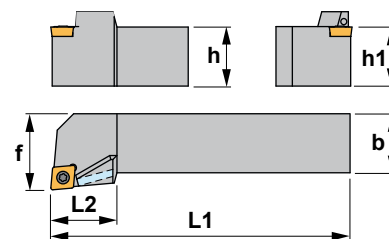

Eigenschaften:

Multifunktions-Klemmhalter mit rhombischen positiven Wendeschneidplatten (80° Winkel).

Für Klemmhalter mit negativen Wendeschneidplatten, siehe MCLN-K (Seite: A81) oder MCLN (Seite: A80) oder PCLN (Seite: A97).

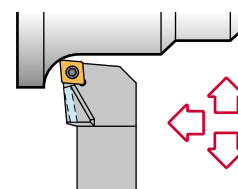

SCLC 95°-A

Reference Bezeichnung	h=h1	b	L1	L2	f	Insert size Wendeschneidplatte	
SCLC R/L 2020 K09-A	20	20	125	22	25	CC.. 09T3..	0,400
SCLC R/L 2525 M09-A	25	25	125	28	32	CC.. 09T3..	0,750

Reference Bezeichnung						Nm
SCLC R/L 2020 K09-A	1240	5515	1506	1592	1598	3.0
SCLC R/L 2525 M09-A	1240	5515	1506	1592	1598	3.0

CC.. 80° rhombic positive inserts with 7° clearance. A30-31
80° rhombische positive Wendeschneidplatten mit 7° Freiwinkel.

Reference / Bez.	l	s	d
CC.. 09T3..	9,65	3,97	9,52

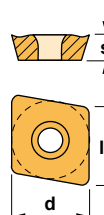

CCGT-AL



CCGT-AP



CCMT



CCMW





Characteristics:
Multipurpose toolholder equipped with rhombic positive insert (angle 80°).
For general applications, roughing, semi-finishing and finishing.

Axial 0°
Radial 0°

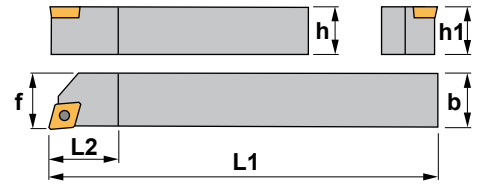

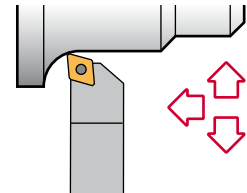

Eigenschaften:
Klemmhalter zum Drehen mit rhombischen positiven Wendeschneidplatte (80° Winkel).
Für allgemeine Anwendungen geeignet (Schlichten, Medium und Schruppen).



SCLC 95° Automatic lathes Drehautomaten

Reference Bezeichnung	h=h1	b	L1	L2	f	Insert size Wendeschneidplatte	
SCLC R/L 0808 M06	8	8	150	8	8	CC.. 0602..	0,070
SCLC R/L 1010 M06	10	10	150	10	10	CC.. 0602..	0,110
SCLC R/L 1212 M06	12	12	150	12	12	CC.. 0602..	0,150
SCLC R/L 1616 M06	16	16	150	16	16	CC.. 0602..	0,280
SCLC R/L 1212 M09	12	12	150	12	12	CC.. 09T3..	0,150
SCLC R/L 1616 M09	16	16	150	16	16	CC.. 09T3..	0,280

Reference Bezeichnung			Nm
SCLC R/L 0808 M06	1225	5507	0.9
SCLC R/L 1010 M06	1225	5507	0.9
SCLC R/L 1212 M06	1225	5507	0.9
SCLC R/L 1616 M06	1225	5507	0.9
SCLC R/L 1212 M09	1240	5515	3.0
SCLC R/L 1616 M09	1240	5515	3.0

CC.. 80° rhombic positive inserts with 7° clearance. A30-31

Reference / Bez.	l	s	d
CC.. 0602..	6,45	2,38	6,35
CC.. 09T3..	9,65	3,97	9,52

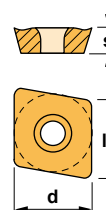

CCGT-AL



CCGT-AP



CCMT



CCMW





Characteristics:
Multipurpose toolholder equipped with rhombic positive insert (angle 55°).
For general applications, roughing, semi-finishing and finishing.

Axial 0°
Radial 0°

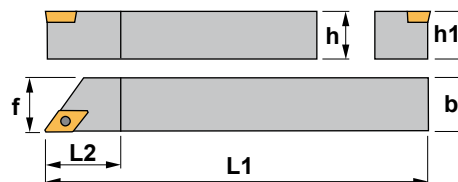

Eigenschaften:
Klemmhalter zum Drehen mit rhombischen positiven Wendeschneidplatte (55° Winkel).
Für allgemeine Anwendungen geeignet (Schlichten, Medium und Schruppen).

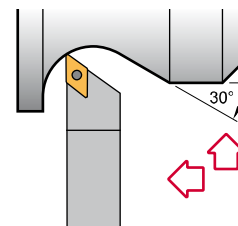

SDAC 90° Automatic lathes Drehautomaten

Reference Bezeichnung	h=h1	b	L1	L2	f	Insert size Wendeschneidplatte	kg
SDAC R/L 0808 M07	8	8	150	12,7	8	DC.. 0702..	0,070
SDAC R/L 1010 M07	10	10	150	15,0	10	DC.. 0702..	0,110
SDAC R/L 1212 M07	12	12	150	15,0	12	DC.. 0702..	0,150
SDAC R/L 1616 M07	16	16	150	16,0	16	DC.. 0702..	0,280
SDAC R/L 1212 M11	12	12	150	18,0	12	DC.. 11T3..	0,150
SDAC R/L 1616 M11	16	16	150	20,0	16	DC.. 11T3..	0,280

Reference Bezeichnung			Nm
SDAC R/L 0808 M07	1225	5507	0.9
SDAC R/L 1010 M07	1225	5507	0.9
SDAC R/L 1212 M07	1225	5507	0.9
SDAC R/L 1616 M07	1225	5507	0.9
SDAC R/L 1212 M11	1240	5515	3.0
SDAC R/L 1616 M11	1240	5515	3.0

DC.. 55° rhombic positive inserts with 7° clearance. A35
55° rhombische positive Wendeschneidplatten mit 7° Freiwinkel.

Reference / Bez.	l	s	d
DC.. 0702..	7,75	2,38	6,35
DC.. 11T3..	11,60	3,97	9,52

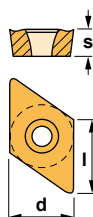

DCGT-AL



DCGT-AP



DCMT



DCMW



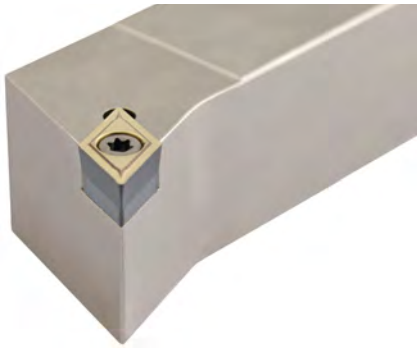

Characteristics:

Multipurpose profiling toolholder equipped with rhombic positive insert (angle 55°).

Axial 0°
Radial 0°

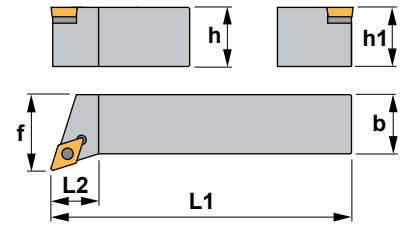

Eigenschaften:

Multifunktions-Klemmhalter zum Profildrehen mit rhombischen positiven Wendeschneidplatten (55° Winkel).

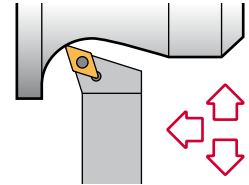

SDHC 107,5°

Reference Bezeichnung	h=h1	b	L1	L2	f	Insert size Wendeschneidplatte	kg
SDHC R/L 1616 H11	16	16	100	20	20	DC.. 11T3..	0,200
SDHC R/L 2020 K11	20	20	125	20	25	DC.. 11T3..	0,400
SDHC R/L 2525 M11	25	25	150	20	32	DC.. 11T3..	0,700

Reference Bezeichnung					Nm
SDHC R/L 1616 H11	1335	5516	3714	1750	3.0
SDHC R/L 2020 K11	1335	5516	3714	1750	3.0
SDHC R/L 2525 M11	1335	5516	3714	1750	3.0

DC.. 55° rhombic positive inserts with 7° clearance. A35
55° rhombische positive Wendeschneidplatten mit 7° Freiwinkel.

Reference / Bez.	l	s	d
DC.. 11T3..	11,60	3,97	9,52

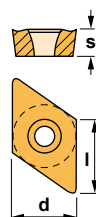

DCGT-AL



DCGT-AP



DCMT



DCMW



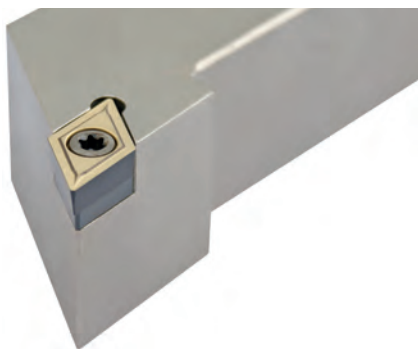

Characteristics:

Multipurpose profiling toolholder equipped with rhombic positive insert (angle 55°).
For toolholders with negative inserts see Ref. MDJN-K (Page: A82) or PDJN (Page: A100).

Axial 0°
Radial 0°

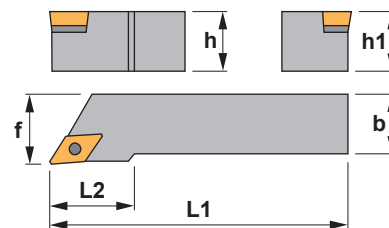

Eigenschaften:

Multifunktions-Klemmhalter zum Profildrehen mit rhombischen positiven Wendeschneidplatten (55° Winkel).

Für Klemmhalter mit negativen Wendeschneidplatten, siehe MDJN-K (Seite: A82) oder PDJN (Seite: A100).

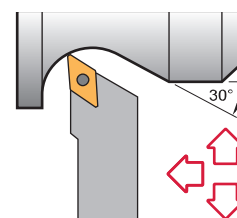

SDJC 93°

Reference Bezeichnung	h=h1	b	L1	L2	f	Insert size Wendeschneidplatte	Kg
SDJC R/L 1010 E07	10	10	70	14	12	DC.. 0702..	0,070
SDJC R/L 1212 F07	12	12	80	16	16	DC.. 0702..	0,100
SDJC R/L 1616 H07	16	16	100	16	20	DC.. 0702..	0,150
SDJC R/L 2020 K07	20	20	125	22	25	DC.. 0702..	0,400
SDJC R/L 1212 F11	12	12	80	18	16	DC.. 11T3..	0,100
SDJC R/L 1616 H11	16	16	100	18	20	DC.. 11T3..	0,200
SDJC R/L 2020 K11	20	20	125	22	25	DC.. 11T3..	0,400
SDJC R/L 2525 M11	25	25	150	28	32	DC.. 11T3..	0,700

Reference Bezeichnung					Nm
SDJC R/L 1010 E07	1225	5507	-	-	0.9
SDJC R/L 1212 F07	1225	5507	-	-	0.9
SDJC R/L 1616 H07	1225	5507	-	-	0.9
SDJC R/L 2020 K07	1225	5507	-	-	0.9
SDJC R/L 1212 F11	1240	5515	-	-	3.0
SDJC R/L 1616 H11	1335	5516	3714	1750	3.0
SDJC R/L 2020 K11	1335	5516	3714	1750	3.0
SDJC R/L 2525 M11	1335	5516	3714	1750	3.0

DC.. 55° rhombic positive inserts with 7° clearance. A35
55° rhombische positive Wendeschneidplatten mit 7° Freiwinkel.

Reference / Bez.	l	s	d
DC.. 0702..	7,75	2,38	6,35
DC.. 11T3..	11,60	3,97	9,52

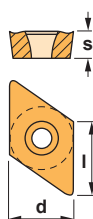

DCGT-AL



DCGT-AP



DCMT



DCMW





Characteristics:

Multipurpose profiling toolholder equipped with rhombic positive insert (angle 55°).
For toolholders with negative inserts see Ref. MDJN-K (Page: A82) or PDJN (Page: A100).

Axial 0°
Radial 0°

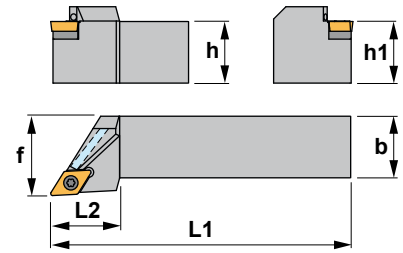

Eigenschaften:

Multifunktions-Klemmhalter zum Profildrehen mit rhombischen positiven Wendeschneidplatten (55° Winkel).

Für Klemmhalter mit negativen Wendeschneidplatten, siehe MDJN-K (Seite: A82) oder PDJN (Seite: A100).

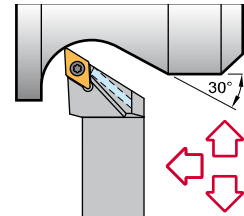

SDJC 93°-A

Reference Bezeichnung	h=h1	b	L1	L2	f	Insert size Wendeschneidplatte	
SDJC R/L 2020 K11-A	20	20	125	22	25	DC.. 11T3..	0,400
SDJC R/L 2525 M11-A	25	25	150	28	32	DC.. 11T3..	0,700

Reference Bezeichnung								Nm
SDJC R/L 2020 K11-A	1335	5516	3714	1750	1506	1592	1598	3.0
SDJC R/L 2525 M11-A	1335	5516	3714	1750	1506	1592	1598	3.0

DC.. 55° rhombic positive inserts with 7° clearance. A35
55° rhombische positive Wendeschneidplatten mit 7° Freiwinkel.

Reference / Bez.	l	s	d
DC.. 11T3..	11,60	3,97	9,52

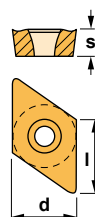

DCGT-AL



DCGT-AP



DCMT



DCMW



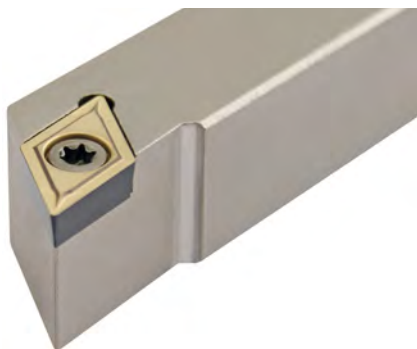

Characteristics:
Multipurpose profiling toolholder equipped with rhombic positive insert (angle 55°).
For general applications, roughing, semi-finishing and finishing.

Axial 0°
Radial 0°

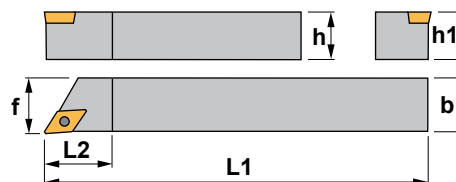

Eigenschaften:
Multifunktions-Klemmhalter zum Profildrehen mit rhombischen positiven Wendeschneidplatten (55° Winkel).
Für allgemeine Anwendungen geeignet (Schlichten, Medium und Schruppen).

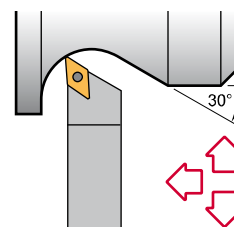

SDJC 93° Automatic lathes Drehautomaten

Reference Bezeichnung	h=h1	b	L1	L2	f	Insert size Wendeschneidplatte	/kg
SDJC R/L 0808 M07	8	8	150	8	8	DC.. 0702..	0,070
SDJC R/L 1010 M07	10	10	150	10	10	DC.. 0702..	0,110
SDJC R/L 1212 M07	12	12	150	12	12	DC.. 0702..	0,150
SDJC R/L 1616 M07	16	16	150	16	16	DC.. 0702..	0,280
SDJC R/L 1212 M11	12	12	150	12	12	DC.. 11T3..	0,150
SDJC R/L 1616 M11	16	16	150	16	16	DC.. 11T3..	0,280

Reference Bezeichnung			Nm
SDJC R/L 0808 M07	1225	5507	0.9
SDJC R/L 1010 M07	1225	5507	0.9
SDJC R/L 1212 M07	1225	5507	0.9
SDJC R/L 1616 M07	1225	5507	0.9
SDJC R/L 1212 M11	1240	5515	3.0
SDJC R/L 1616 M11	1240	5515	3.0

DC.. 55° rhombic positive inserts with 7° clearance. A35
55° rhombische positive Wendeschneidplatten mit 7° Freiwinkel.

Reference / Bez.	l	s	d
DC.. 0702..	7,75	2,38	6,35
DC.. 11T3..	11,60	3,97	9,52

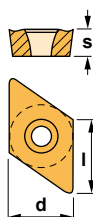

DCGT-AL



DCGT-AP



DCMT



DCMW





Characteristics:

Multipurpose profiling toolholder equipped with rhombic positive insert (angle 55°).
For toolholders with negative inserts see Ref. PDNN (Page: A101).

Axial 0°
Radial 0°

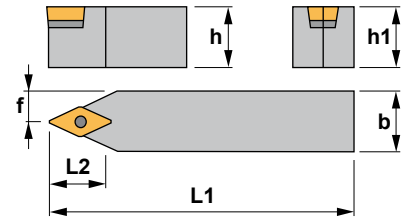

Eigenschaften: Multifunktions-Klemmhalter zum Profildrehen mit rhombischen positiven Wendeschneidplatten (55° Winkel).
Für Klemmhalter mit negativen Wendeschneidplatten, siehe PDNN (Seite: A101).

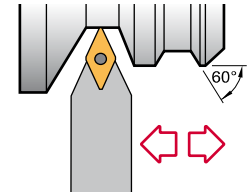

SDNC 62°30'

Reference Bezeichnung	h=h1	b	L1	L2	f	Insert size Wendeschneidplatte	Kg
SDNC N 0808 D07	8	8	60	16	4,0	DC.. 0702..	0,050
SDNC N 1010 E07	10	10	70	16	5,0	DC.. 0702..	0,070
SDNC N 1212 F07	12	12	80	18	6,0	DC.. 0702..	0,100
SDNC N 1616 H11	16	16	100	22	8,0	DC.. 11T3..	0,200
SDNC N 2020 K11	20	20	125	22	10,0	DC.. 11T3..	0,400
SDNC N 2525 M11	25	25	150	22	12,5	DC.. 11T3..	0,700

Reference Bezeichnung					Nm
SDNC N 0808 D07	1225	5507	-	-	0.9
SDNC N 1010 E07	1225	5507	-	-	0.9
SDNC N 1212 F07	1225	5507	-	-	0.9
SDNC N 1616 H11	1335	5516	3714	1750	3.0
SDNC N 2020 K11	1335	5516	3714	1750	3.0
SDNC N 2525 M11	1335	5516	3714	1750	3.0

DC.. 55° rhombic positive inserts with 7° clearance. A35
55° rhombische positive Wendeschneidplatten mit 7° Freiwinkel.

Reference / Bez.	l	s	d
DC.. 0702..	7,75	2,38	6,35
DC.. 11T3..	11,60	3,97	9,52

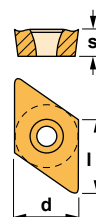

DCGT-AL



DCGT-AP



DCMT



DCMW



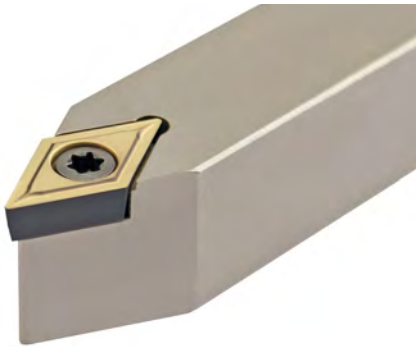

Characteristics:
Multipurpose external turning toolholder equipped with rhombic positive insert (angle 55°).
For general applications, roughing, semi-finishing and finishing.

Axial 0°
Radial 0°

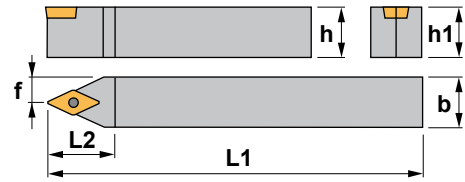

Eigenschaften:
Klemmhalter zum Drehen mit rhombischen positiven Wendeschneidplatte (55° Winkel).
Für allgemeine Anwendungen geeignet (Schlichten, Medium und Schruppen).

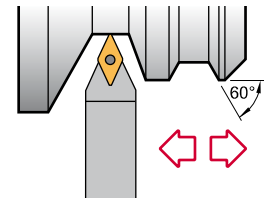

SDNC 62°30' i Automatic lathes Drehautomaten

Reference Bezeichnung	h=h1	b	L1	L2	f	Insert size Wendeschneidplatte	KG
SDNC N 1010 M07	10	10	150	15	5,2	DC.. 0702..	0,100
SDNC N 1212 M11	12	12	150	21	6,2	DC.. 11T3..	0,140
SDNC N 1616 M11	16	16	150	21	8,6	DC.. 11T3..	0,270

Reference Bezeichnung			Nm
SDNC N 1010 M07	1225	5507	0.9
SDNC N 1212 M11	1240	5515	3.0
SDNC N 1616 M11	1240	5515	3.0

DC.. 55° rhombic positive inserts with 7° clearance. i A35
55° rhombische positive Wendeschneidplatten mit 7° Freiwinkel.

Reference / Bez.	l	s	d
DC.. 0702..	7,75	2,38	6,35
DC.. 11T3..	11,60	3,97	9,52

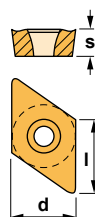

DCGT-AL



DCGT-AP



DCMT



DCMW



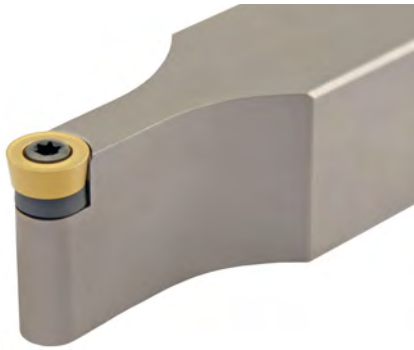

Characteristics:

Profiling toolholder equipped with round positive insert.
For lever lock toolholders see Ref. PRDC (Page: A102).

Axial 0°
Radial 0°

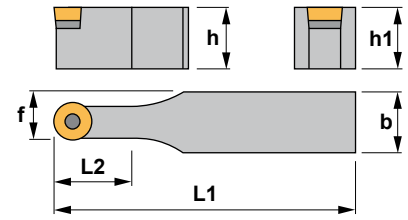

Eigenschaften:

Klemmhalter zum Profildrehen mit runden positiven Wendeschneidplatten.
Für Klemmhalter mit Kniehebel-Klemmung, siehe PRDC (Seite: A102).

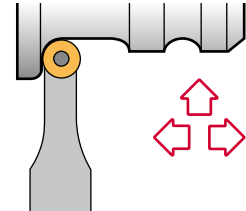

SRDC

Reference Bezeichnung	h=h1	b	L1	L2	f	Insert size Wendeschneidplatte	
SRDC N 1010 E06	10	10	70	10	8,0	RC.. 0602M0	0,070
SRDC N 1212 F06	12	12	80	12	9,0	RC.. 0602M0	0,100
SRDC N 1616 H06	16	16	100	16	11,0	RC.. 0602M0	0,200
SRDC N 2020 K06	20	20	125	20	13,0	RC.. 0602M0	0,400
SRDC N 2525 M06	25	25	150	25	15,5	RC.. 0602M0	0,700
SRDC N 1616 H08	16	16	100	16	12,0	RC.. 0803M0	0,200
SRDC N 2020 K08	20	20	125	20	14,0	RC.. 0803M0	0,400
SRDC N 2525 M08	25	25	150	25	16,5	RC.. 0803M0	0,700
SRDC N 2020 K10	20	20	125	22	15,0	RC.. 10T3M0	0,400
SRDC N 2525 M10	25	25	150	22	17,5	RC.. 10T3M0	0,700
SRDC N 2020 K12	20	20	125	28	16,0	RC.. 1204M0	0,400
SRDC N 2525 M12	25	25	150	28	18,5	RC.. 1204M0	0,700
SRDC N 3225 P12	32	25	170	28	18,5	RC.. 1204M0	0,900
SRDC N 3232 P12	32	32	170	28	22,0	RC.. 1204M0	1,200

Reference Bezeichnung					Nm
SRDC N.....06	1225	5507	-	-	0.9
SRDC N.....08	1230	5508	-	-	1.2
SRDC N.....10	1335	5516	3811	1750	3.0
SRDC N.....12	1335	5516	3814	1750	3.0

RC..

Round positive inserts with 7° clearance. A38-39
Runde positive Wendeschneidplatten mit 7° Freiwinkel.

Reference / Bez.	s	d
RC.. 0602M0	2,38	6,00
RC.. 0803M0	3,18	8,00
RC.. 10T3M0	3,97	10,00
RC.. 1204M0	4,76	12,00

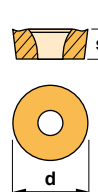

RCGT-AL



RCGT-AP



RCMT



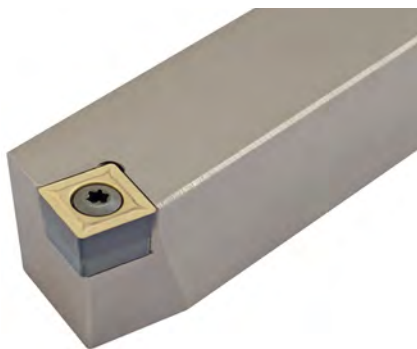

Characteristics:

Toolholder for external turning applications equipped with square positive inserts.

For toolholders with negative inserts see Ref. PSBN (Page: A105).

Axial 0°
Radial 0°

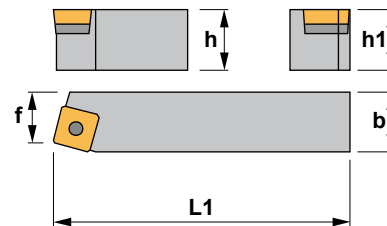

Eigenschaften:

Klemhalter zum Außendrehen mit vierkantigen positiven Wendeschneidplatten.

Für Klemhalter mit negativen Wendeschneidplatten, siehe PSBN (Seite: A105).

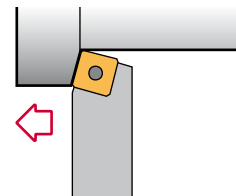

SSBC 75°

Reference Bezeichnung	h=h1	b	L1	f	Insert size Wendeschneidplatte	kg
SSBC R/L 1212 F09	12	12	80	11	SC.. 09T3..	0,100
SSBC R/L 1616 H09	16	16	100	13	SC.. 09T3..	0,200
SSBC R/L 2020 K12	20	20	125	17	SC.. 1204..	0,400
SSBC R/L 2525 M12	25	25	150	22	SC.. 1204..	0,700

Reference Bezeichnung					Nm
SSBC R/L 1212 F09	1240	5515	-	-	3.0
SSBC R/L 1616 H09	1240	5515	-	-	3.0
SSBC R/L 2020 K12	1540	5517	3514	1760	3.0
SSBC R/L 2525 M12	1540	5517	3514	1760	3.0

SC..

Square positive inserts with 7° clearance. A40
Vierkantige positive Wendeschneidplatten mit 7° Freiwinkel.

Reference / Bez.	l	s	d
SC.. 09T3..	9,52	3,97	9,52
SC.. 1204..	12,70	4,76	12,70

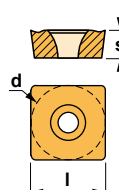

SCGT-AL



SCMT



SCMT-39



SCMW



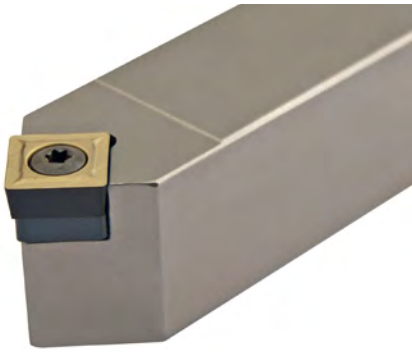

Characteristics:

Toolholder for external turning and chamfering applications equipped with square positive inserts.

For toolholders with negative inserts see Ref. PSDN (Page: A106).

Axial 0°
Radial 0°

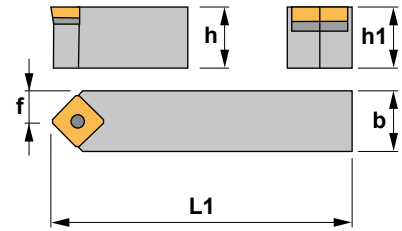

Eigenschaften:

Klemhalter zum Außendrehen und Abschrägen mit vierkantigen positiven Wendeschneidplatten.

Für Klemhalter mit negativen Wendeschneidplatten, siehe PSDN (Seite: A106).

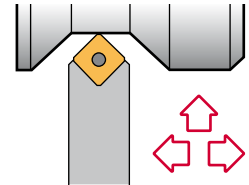

SSDC 45°

Reference Bezeichnung	h=h1	b	L1	f	Insert size Wendeschneidplatte	
SSDC N 1212 F09	12	12	80	6,0	SC.. 09T3..	0,100
SSDC N 1616 H09	16	16	100	8,0	SC.. 09T3..	0,200
SSDC N 2020 K12	20	20	125	10,0	SC.. 1204..	0,400
SSDC N 2525 M12	25	25	150	12,5	SC.. 1204..	0,700

Reference Bezeichnung					Nm
SSDC N 1212 F09	1240	5515	-	-	3.0
SSDC N 1616 H09	1240	5515	-	-	3.0
SSDC N 2020 K12	1540	5517	3514	1760	3.0
SSDC N 2525 M12	1540	5517	3514	1760	3.0

SC.. Square positive inserts with 7° clearance. A40
Vierkantige positive Wendeschneidplatten mit 7° Freiwinkel.

Reference / Bez.	l	s	d
SC.. 09T3..	9,52	3,97	9,52
SC.. 1204..	12,70	4,76	12,70

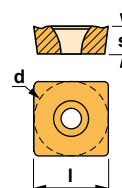

SCGT-AL



SCMT



SCMT-39



SCMW



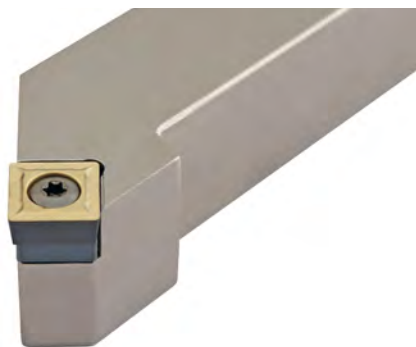

Characteristics:

Toolholder for external turning and chamfering applications equipped with square positive inserts.

For toolholders with negative inserts see Ref. PSSN (Page: A108).

Axial 0°
Radial 0°

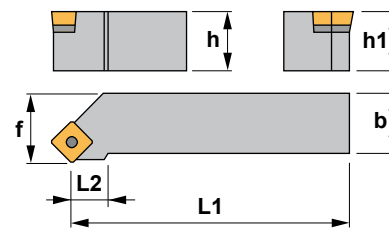

Eigenschaften:

Klemmhalter zum Außendreifen und Abschrägen mit vierkantigen positiven Wendeschneidplatten.

Für Klemmhalter mit negativen Wendeschneidplatten, siehe PSSN (Seite: A108).

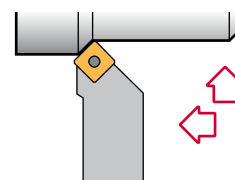

SSSC 45°

Reference Bezeichnung	h=h1	b	L1	L2	f	Insert size Wendeschneidplatte	kg
SSSC R/L 1212 F09	12	12	80	20	16	SC.. 09T3..	0,100
SSSC R/L 1616 H09	16	16	100	22	20	SC.. 09T3..	0,200
SSSC R/L 2020 K12	20	20	125	25	25	SC.. 1204..	0,400
SSSC R/L 2525 M12	25	25	150	28	32	SC.. 1204..	0,700

Reference Bezeichnung					Nm
SSSC R/L 1212 F09	1240	5515	-	-	3.0
SSSC R/L 1616 H09	1240	5515	-	-	3.0
SSSC R/L 2020 K12	1540	5517	3514	1760	3.0
SSSC R/L 2525 M12	1540	5517	3514	1760	3.0

SC..

Square positive inserts with 7° clearance. A40
Vierkantige positive Wendeschneidplatten mit 7° Freiwinkel.

Reference / Bez.	l	s	d
SC.. 09T3..	9,52	3,97	9,52
SC.. 1204..	12,70	4,76	12,70

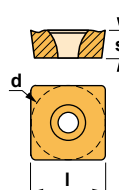

SCGT-AL



SCMT



SCMT-39



SCMW



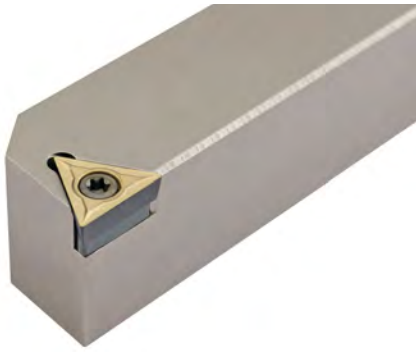

Characteristics:

Toolholder for external turning applications equipped with triangular positive inserts. For all kind of materials. The workpiece should be stable.

Axial 0°
Radial 0°

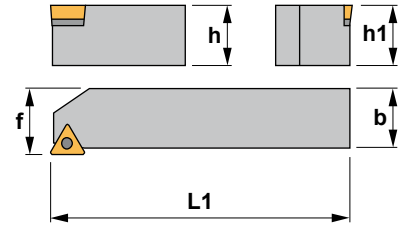

Eigenschaften:

Klemmhalter zum Außendrehen mit dreikantigen positiven Wendeschneidplatten. Geeignet für alle Materialien. Das Werkstück muß stabil sein.

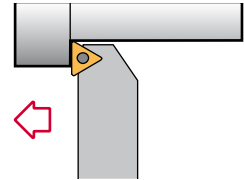

STAC 90°

Reference Bezeichnung	h=h1	b	L1	f	Insert size Wendeschneidplatte	Kg
STAC R/L 0808 D09	8	8	60	8,5	TC.. 0902..	0,050
STAC R/L 1010 E09	10	10	70	10,5	TC.. 0902..	0,070
STAC R/L 1212 F11	12	12	80	12,5	TC.. 1102..	0,100
STAC R/L 1616 H11	16	16	100	16,5	TC.. 1102..	0,200
STAC R/L 1616 H16	16	16	100	16,5	TC.. 16T3..	0,200
STAC R/L 2020 K16	20	20	125	20,5	TC.. 16T3..	0,400
STAC R/L 2525 M16	25	25	150	25,5	TC.. 16T3..	0,700

Reference Bezeichnung					Nm
STAC R/L 0808 D09	1222	5506	-	-	0.6
STAC R/L 1010 E09	1222	5506	-	-	0.6
STAC R/L 1212 F11	1225	5507	-	-	0.9
STAC R/L 1616 H11	1225	5507	-	-	0.9
STAC R/L 1616 H16	1335	5516	3414	1750	3.0
STAC R/L 2020 K16	1335	5516	3414	1750	3.0
STAC R/L 2525 M16	1335	5516	3414	1750	3.0

TC.. Triangular positive inserts with 7° clearance. A44
Dreikantige positive Wendeschneidplatten mit 7° Freiwinkel.

Reference / Bez.	l	s	d
TC.. 0902..	9,62	2,38	5,55
TC.. 1102..	11,00	2,38	6,35
TC.. 16T3..	16,50	3,97	9,52

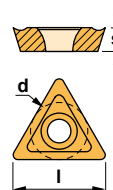

TCGT-AL



TCMT



TCMW





Characteristics:

Toolholder for external turning and chamfering applications equipped with triangular positive inserts.

For toolholders with negative inserts see Ref. PTDN (Page: A109).

Axial 0°
Radial 0°

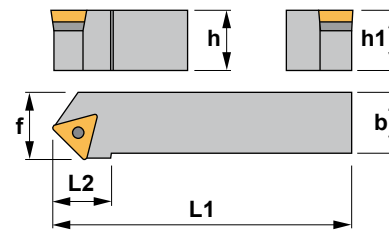

Eigenschaften:

Klemmhalter zum Außendreihen und Abschrägen mit dreikantigen positiven Wendeschneidplatten.

Für Klemmhalter mit negativen Wendeschneidplatten, siehe PTDN (Seite: A109).

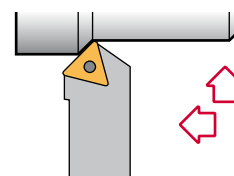

STDC 45°

Reference Bezeichnung	h=h1	b	L1	L2	f	Insert size Wendeschneidplatte	Kg
STDC R/L 0808 D09	8	8	60	12	10	TC.. 0902..	0,050
STDC R/L 1010 E09	10	10	70	14	11	TC.. 0902..	0,070
STDC R/L 1212 F11	12	12	80	16	13	TC.. 1102..	0,100
STDC R/L 1616 H11	16	16	100	18	17	TC.. 1102..	0,200
STDC R/L 1212 F16	12	12	80	18	17	TC.. 16T3..	0,100
STDC R/L 1616 H16	16	16	100	18	17	TC.. 16T3..	0,200
STDC R/L 2020 K16	20	20	125	22	22	TC.. 16T3..	0,400
STDC R/L 2525 M16	25	25	150	28	27	TC.. 16T3..	0,700

Reference Bezeichnung					Nm
STDC R/L 0808 D09	1222	5506	-	-	0.6
STDC R/L 1010 E09	1222	5506	-	-	0.6
STDC R/L 1212 F11	1225	5507	-	-	0.9
STDC R/L 1616 H11	1225	5507	-	-	0.9
STDC R/L 1212 F16	1240	5515	-	-	3.0
STDC R/L 1616 H16	1335	5516	3414	1750	3.0
STDC R/L 2020 K16	1335	5516	3414	1750	3.0
STDC R/L 2525 M16	1335	5516	3414	1750	3.0

TC..

Triangular positive inserts with 7° clearance. A44
Dreikantige positive Wendeschneidplatten mit 7° Freiwinkel.

Reference / Bez.	l	s	d
TC.. 0902..	9,62	2,38	5,55
TC.. 1102..	11,00	2,38	6,35
TC.. 16T3..	16,50	3,97	9,52

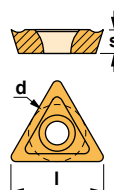

TCGT-AL



TCMT



TCMW





Characteristics:

Toolholder for face turning applications equipped with triangular positive inserts. For toolholders with negative inserts see Ref. PTFN (Page: A110).

Axial 0°
Radial 0°

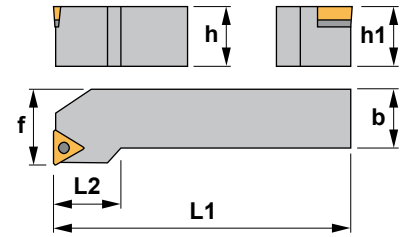

Eigenschaften:

Klemmhalter zum Plandrehen mit dreikantigen positiven Wendeschneidplatten. Für Klemmhalter mit negativen Wendeschneidplatten, siehe PTFN (Seite: A110).

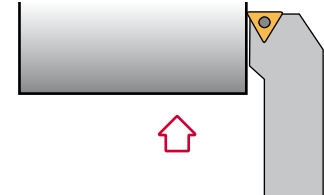

STFC 90°

Reference Bezeichnung	h=h1	b	L1	L2	f	Insert size Wendeschneidplatte	KG
STFC R/L 0808 D09	8	8	60	12	10	TC.. 0902..	0,050
STFC R/L 1010 E09	10	10	70	14	12	TC.. 0902..	0,070
STFC R/L 1212 F11	12	12	80	16	16	TC.. 1102..	0,100
STFC R/L 1616 H11	16	16	100	18	20	TC.. 1102..	0,200
STFC R/L 1212 F16	12	12	80	16	16	TC.. 16T3..	0,100
STFC R/L 1616 H16	16	16	100	22	20	TC.. 16T3..	0,200
STFC R/L 2020 K16	20	20	125	22	25	TC.. 16T3..	0,400
STFC R/L 2525 M16	25	25	150	28	32	TC.. 16T3..	0,700

Reference Bezeichnung					Nm
STFC R/L 0808 D09	1222	5506	-	-	0.6
STFC R/L 1010 E09	1222	5506	-	-	0.6
STFC R/L 1212 F11	1225	5507	-	-	0.9
STFC R/L 1616 H11	1225	5507	-	-	0.9
STFC R/L 1212 F16	1240	5515	-	-	3.0
STFC R/L 1616 H16	1335	5516	3414	1750	3.0
STFC R/L 2020 K16	1335	5516	3414	1750	3.0
STFC R/L 2525 M16	1335	5516	3414	1750	3.0

TC.. Triangular positive inserts with 7° clearance. A44
Dreikantige positive Wendeschneidplatten mit 7° Freiwinkel.

Reference / Bez.	l	s	d
TC.. 0902..	9,62	2,38	5,55
TC.. 1102..	11,00	2,38	6,35
TC.. 16T3..	16,50	3,97	9,52

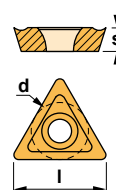

TCGT-AL



TCMT



TCMW





Characteristics:

Toolholder for external turning applications equipped with triangular positive inserts. For toolholders with negative inserts see Ref. PTGN (Page: A111).

Axial 0°
Radial 0°

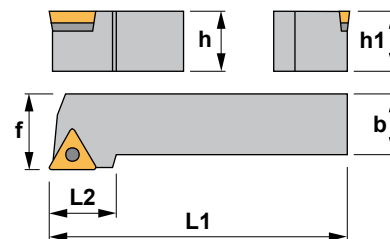

Eigenschaften:

Klemmhalter zum Außendrehen mit dreikantigen positiven Wendeschneidplatten. Für Klemmhalter mit negativen Wendeschneidplatten, siehe PTGN (Seite: A111).

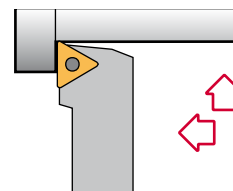

STGC 90°

Reference Bezeichnung	h=h1	b	L1	L2	f	Insert size Wendeschneidplatte	kg
STGC R/L 0808 D09	8	8	60	12	10	TC.. 0902..	0,050
STGC R/L 1010 E09	10	10	70	14	12	TC.. 0902..	0,070
STGC R/L 1212 F11	12	12	80	16	16	TC.. 1102..	0,100
STGC R/L 1616 H11	16	16	100	18	20	TC.. 1102..	0,200
STGC R/L 1212 F16	12	12	80	18	16	TC.. 16T3..	0,100
STGC R/L 1616 H16	16	16	100	18	20	TC.. 16T3..	0,200
STGC R/L 2020 K16	20	20	125	22	25	TC.. 16T3..	0,400
STGC R/L 2525 M16	25	25	150	28	32	TC.. 16T3..	0,700

Reference Bezeichnung					Nm
STGC R/L 0808 D09	1222	5506	-	-	0.6
STGC R/L 1010 E09	1222	5506	-	-	0.6
STGC R/L 1212 F11	1225	5507	-	-	0.9
STGC R/L 1616 H11	1225	5507	-	-	0.9
STGC R/L 1212 F16	1240	5515	-	-	3.0
STGC R/L 1616 H16	1335	5516	3414	1750	3.0
STGC R/L 2020 K16	1335	5516	3414	1750	3.0
STGC R/L 2525 M16	1335	5516	3414	1750	3.0

TC.. <small>Triangular positive inserts with 7° clearance. Dreikantige positive Wendeschneidplatten mit 7° Freiwinkel. A44</small>			
Reference / Bez.	l	s	d
TC.. 0902..	9,62	2,38	5,55
TC.. 1102..	11,00	2,38	6,35
TC.. 16T3..	16,50	3,97	9,52

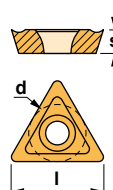

TCGT-AL



TCMT



TCMW





Characteristics:

Toolholder for external and face turning applications equipped with triangular positive inserts.

For toolholders with negative inserts see Ref. MTJN (Page: A86) or MTJN-K (Page: A87).

Axial 0°
Radial 0°

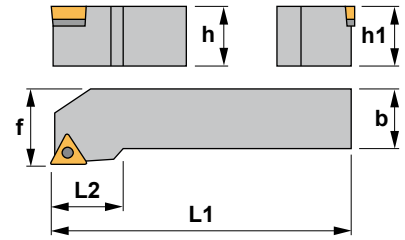

Eigenschaften:

Klemmhalter zum Außen- und Plandrehen mit dreikantigen positiven Wendeschneidplatten.

Für Klemmhalter mit negativen Wendeschneidplatten, siehe MTJN (Seite: A86) oder MTJN-K (Seite: A87).

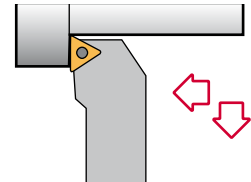

STJC 93°

Reference Bezeichnung	h=h1	b	L1	L2	f	Insert size Wendeschneidplatte	
STJC R/L 0808 D09	8	8	60	12	10	TC.. 0902..	0,050
STJC R/L 1010 E09	10	10	70	14	12	TC.. 0902..	0,070
STJC R/L 1212 F11	12	12	80	16	16	TC.. 1102..	0,100
STJC R/L 1616 H11	16	16	100	18	20	TC.. 1102..	0,200
STJC R/L 1212 F16	12	12	80	18	16	TC.. 16T3..	0,100
STJC R/L 1616 H16	16	16	100	18	20	TC.. 16T3..	0,200
STJC R/L 2020 K16	20	20	125	22	25	TC.. 16T3..	0,400
STJC R/L 2525 M16	25	25	150	28	32	TC.. 16T3..	0,700

Reference Bezeichnung					Nm
STJC R/L 0808 D09	1222	5506	-	-	0.6
STJC R/L 1010 E09	1222	5506	-	-	0.6
STJC R/L 1212 F11	1225	5507	-	-	0.9
STJC R/L 1616 H11	1225	5507	-	-	0.9
STJC R/L 1212 F16	1240	5515	-	-	3.0
STJC R/L 1616 H16	1335	5516	3414	1750	3.0
STJC R/L 2020 K16	1335	5516	3414	1750	3.0
STJC R/L 2525 M16	1335	5516	3414	1750	3.0

TC.. Triangular positive inserts with 7° clearance. A44
Dreikantige positive Wendeschneidplatten mit 7° Freiwinkel.

Reference / Bez.	l	s	d
TC.. 0902..	9,62	2,38	5,55
TC.. 1102..	11,00	2,38	6,35
TC.. 16T3..	16,50	3,97	9,52

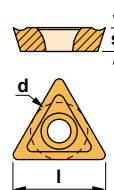

TCGT-AL



TCMT



TCMW





Characteristics:

Toolholder for external and face turning applications equipped with triangular positive inserts.

For all kind of materials. The workpiece should be stable.

Axial 0°
Radial 0°

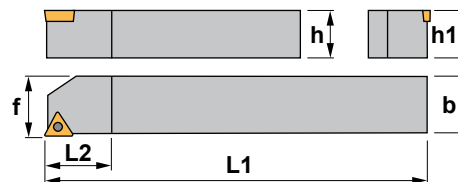

Eigenschaften:

Klemmhalter zum Drehen und Plandrehen mit dreikantigen positiven Wendeschneidplatten.

Für alle Materialien geeignet.

Das Werkstück sollte stabil sein.

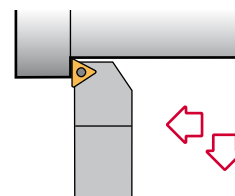

STJC 93°

i Automatic lathes
Drehautomaten

Reference Bezeichnung	h=h1	b	L1	L2	f	Insert size Wendeschneidplatte	kg
STJC R/L 1010 M11	10	10	150	16	10	TC.. 1102..	0,110
STJC R/L 1212 M11	12	12	150	16	12	TC.. 1102..	0,150
STJC R/L 1616 M11	16	16	150	16	16	TC.. 1102..	0,280

Reference Bezeichnung			Nm
STJC R/L 1010 M11	1225	5507	0.9
STJC R/L 1212 M11	1225	5507	0.9
STJC R/L 1616 M11	1225	5507	0.9

TC.. Triangular positive inserts with 7° clearance. **i** A44
Dreikantige positive Wendeschneidplatten mit 7° Freiwinkel.

Reference / Bez.	l	s	d
TC.. 1102..	11,00	2,38	6,35

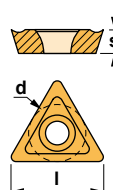

TCGT-AL



TCMT



TCMW





Characteristics:

Toolholder for external turning and chamfering applications equipped with triangular positive inserts.

For toolholders with negative inserts see Ref. PTTN (Page: A112).

Axial 0°
Radial 0°

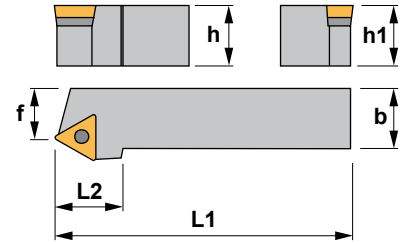

Eigenschaften:

Klemmhalter zum Außendrehen und Abschrägen mit dreikantigen positiven Wendeschneidplatten.

Für Klemmhalter mit negativen Wendeschneidplatten, siehe PTTN (Seite: A112).

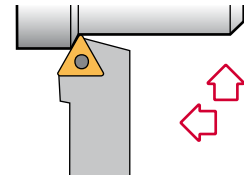

STTC 60°

Reference Bezeichnung	h=h1	b	L1	L2	f	Insert size Wendeschneidplatte	Kg
STTC R/L 0808 D09	8	8	60	12	7	TC.. 0902..	0,050
STTC R/L 1010 E09	10	10	70	14	9	TC.. 0902..	0,070
STTC R/L 1212 F11	12	12	80	16	11	TC.. 1102..	0,100
STTC R/L 1616 H11	16	16	100	18	13	TC.. 1102..	0,200
STTC R/L 1212 F16	12	12	80	18	11	TC.. 16T3..	0,100
STTC R/L 1616 H16	16	16	100	18	13	TC.. 16T3..	0,200
STTC R/L 2020 K16	20	20	125	22	17	TC.. 16T3..	0,400
STTC R/L 2525 M16	25	25	150	28	22	TC.. 16T3..	0,700

Reference Bezeichnung					Nm
STTC R/L 0808 D09	1222	5506	-	-	0.6
STTC R/L 1010 E09	1222	5506	-	-	0.6
STTC R/L 1212 F11	1225	5507	-	-	0.9
STTC R/L 1616 H11	1225	5507	-	-	0.9
STTC R/L 1212 F16	1240	5515	-	-	3.0
STTC R/L 1616 H16	1335	5516	3414	1750	3.0
STTC R/L 2020 K16	1335	5516	3414	1750	3.0
STTC R/L 2525 M16	1335	5516	3414	1750	3.0

TC..

Triangular positive inserts with 7° clearance. A44
Dreikantige positive Wendeschneidplatten mit 7° Freiwinkel.

Reference / Bez.	l	s	d
TC.. 0902..	9,62	2,38	5,55
TC.. 1102..	11,00	2,38	6,35
TC.. 16T3..	16,50	3,97	9,52

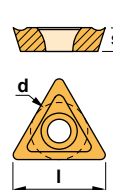

TCGT-AL



TCMT



TCMW





Characteristics:

Toolholder equipped with parallelogram and triangular positive inserts.
For chamfering applications.

Axial 0°
Radial 0°

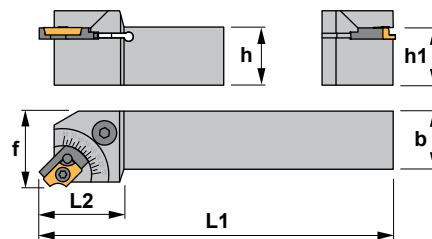

Eigenschaften:

Klemhalter zum Abschrägen mit parallelogramme und dreikantigen positiven Wendeschneidplatten.

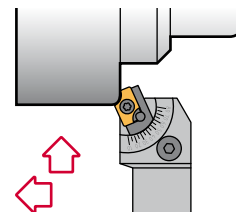

STXC 10°- 80°

Reference Bezeichnung	h=h1	b	L1	L2	f	Insert size Wendeschneidplatte	Kg
STXC R 2020 K16	20	20	125	27	25	ADMT 1503.. / TCMT 16T3..	0,620
STXC R 2525 M16	25	25	150	27	32	ADMT 1503.. / TCMT 16T3..	0,790

Reference Bezeichnung							Nm ¹	Nm ²
STXC R 2020 K16	1240	5515	1496	5004	6925	6926	3.0	3.5
STXC R 2525 M16	1240	5515	1496	5004	6925	6926	3.0	3.5

ADMT-R

Parallelogram positive inserts with 15° clearance. A30
Parallelogramme positive WSP mit 15° Freiwinkel.

Reference / Bezeichnung	r	s	d
ADMT 1503R1.0	1.0	3,18	9,52
ADMT 1503R1.5	1.5	3,18	9,52
ADMT 1503R2.0	2.0	3,18	9,52
ADMT 1503R2.5	2.5	3,18	9,52
ADMT 1503R3.0	3.0	3,18	9,52
ADMT 1503R3.5	3.5	3,18	9,52
ADMT 1503R4.0	4.0	3,18	9,52
ADMT 1503R4.5	4.5	3,18	9,52
ADMT 1503R5.0	5.0	3,18	9,52

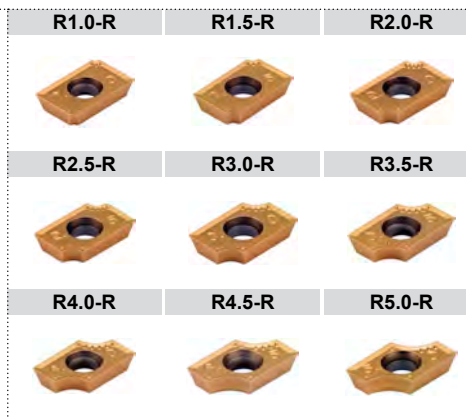
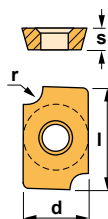

TCMT

Triangular positive insert with 7° clearance. A44
Dreikantige positive Wendeschneidplatte mit 7° Freiwinkel.

Reference / Bez.	l	s	d
TCMT 16T3..	16,50	3,97	9,52

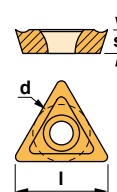



Characteristics:
Multipurpose profiling toolholder equipped with rhombic positive insert (angle 55°).
For general applications, roughing, semi-finishing and finishing.

Axial 0°
Radial 0°

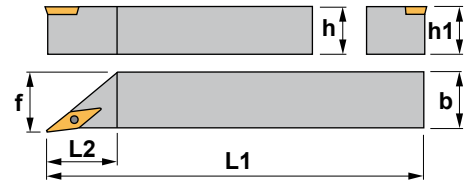

Eigenschaften:
Multifunktions-Klemmhalter zum Profildrehen mit rhombischen positiven Wendeschneidplatten (55° Winkel).
Für allgemeine Anwendungen geeignet (Schlichten, Medium und Schruppen).

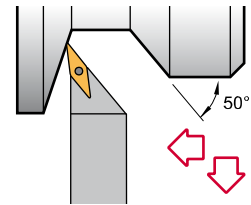

SVAC 90° Automatic lathes Drehautomaten

Reference Bezeichnung	h=h1	b	L1	L2	f	Insert size Wendeschneidplatte	
SVAC R/L 0808 M11	8	8	150	26	8	VC.. 1103..	0,070
SVAC R/L 1010 M11	10	10	150	26	10	VC.. 1103..	0,100
SVAC R/L 1212 M11	12	12	150	26	12	VC.. 1103..	0,140
SVAC R/L 1616 M11	16	16	150	26	16	VC.. 1103..	0,270
SVAC R/L 1212 M16	12	12	150	40	12	VC.. 1604..	0,140
SVAC R/L 1616 M16	16	16	150	40	16	VC.. 1604..	0,270

Reference Bezeichnung			Nm
SVAC R/L 0808 M11	1225	5507	0.9
SVAC R/L 1010 M11	1225	5507	0.9
SVAC R/L 1212 M11	1225	5507	0.9
SVAC R/L 1616 M11	1225	5507	0.9
SVAC R/L 1212 M16	1240	5515	3.0
SVAC R/L 1616 M16	1240	5515	3.0

VC.. 35° rhombic positive inserts with 7° clearance. A48
35° rhombische positive Wendeschneidplatten mit 7° Freiwinkel.

Reference / Bez.	l	s	d
VC.. 1103..	11,00	3,18	6,35
VC.. 1604..	16,50	4,76	9,52

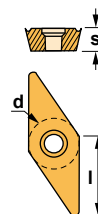

VCGT-AL



VCGT-AP



VCMT





Characteristics:

Multipurpose profiling toolholder equipped with rhombic positive insert (angle 35°).

For general applications, semi-finishing and finishing.

Axial 0°
Radial 0°

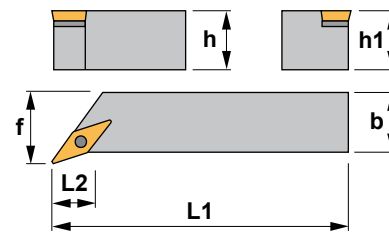

Eigenschaften:

Multifunktions-Klemmhalter zum Profildrehen mit rhombischen positiven Wendeschneidplatten (35° Winkel).

Für allgemeine Anwendungen, Schruppen, Vorschlichten und Schlichten.

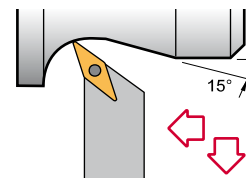

SVHC 107°30'

Reference Bezeichnung	h=h1	b	L1	L2	f	Insert size Wendeschneidplatte	Kg
SVHC R/L 2020 K16	20	20	125	28	25	VC.. 1604..	0,400
SVHC R/L 2525 M16	25	25	150	28	32	VC.. 1604..	0,700
SVHC R/L 3225 P16	32	25	170	34	32	VC.. 1604..	0,900
SVHC R/L 2525 M22	25	25	150	28	32	VC.. 2205..	0,700
SVHC R/L 3225 P22	32	25	170	34	32	VC.. 2205..	0,900

Reference Bezeichnung					Nm
SVHC R/L 2020 K16	1335	5516	3718	1750	3.0
SVHC R/L 2525 M16	1335	5516	3718	1750	3.0
SVHC R/L 3225 P16	1335	5516	3718	1750	3.0
SVHC R/L 2525 M22	1540	5520	3722	1760	3.0
SVHC R/L 3225 P22	1540	5520	3722	1760	3.0

VC.. 35° rhombic positive inserts with 7° clearance. A48
35° rhombische positive Wendeschneidplatten mit 7° Freiwinkel.

Reference / Bez.	l	s	d
VC.. 1604..	16,50	4,76	9,52
VC.. 2205..	22,10	5,56	12,70

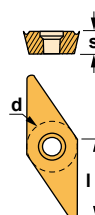

VCGT-AL



VCGT-AP



VCMT



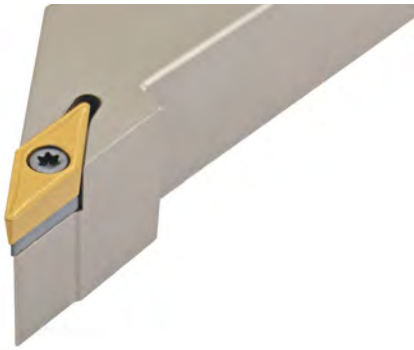

Characteristics:

Multipurpose profiling toolholder equipped with rhombic 5° positive insert (angle 35°). For toolholders with negative inserts see Ref. MVJN-K (Page: A89).

Axial 0°
Radial 0°

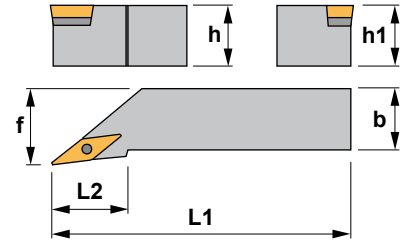

Eigenschaften:

Multifunktions-Klemmhalter zum Profildrehen mit 5° rhombischen positiven Wendeschneidplatten (35° Winkel).

Für Klemmhalter mit negativen Wendeschneidplatten, siehe MVJN-K (Seite: A89).

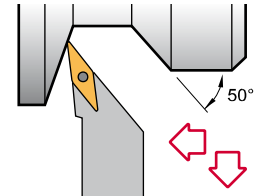

SVJB 93°

Reference Bezeichnung	h=h1	b	L1	L2	f	Insert size Wendeschneidplatte	Kg
SVJB R/L 2020 K16	20	20	125	34	25	VBMT 1604..	0,400
SVJB R/L 2525 M16	25	25	150	34	32	VBMT 1604..	0,700
SVJB R/L 3225 P16	32	25	170	38	32	VBMT 1604..	0,900

Reference Bezeichnung					Nm
SVJB R/L 2020 K16	1335	5516	3718	1750	3.0
SVJB R/L 2525 M16	1335	5516	3718	1750	3.0
SVJB R/L 3225 P16	1335	5516	3718	1750	3.0

VBMT

35° rhombic positive insert with 5° clearance. A48
35° rhombische positive Wendeschneidplatte mit 5° Freiwinkel. A48

Reference / Bez.

l

s

d

VBMT 1604..

16,50

4,76

9,52

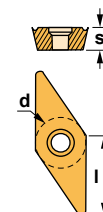

VBMT





Characteristics:

Multipurpose profiling toolholder equipped with rhombic positive insert (angle 35°). For toolholders with negative inserts see Ref. MVJN-K (Page: A89).

Axial 0°
Radial 0°

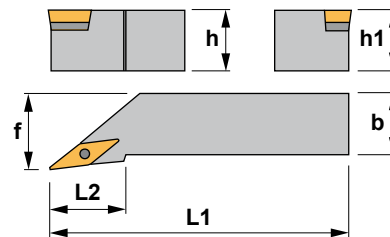

Eigenschaften:

Multifunktions-Klemmhalter zum Profildrehen mit rhombischen positiven Wendschneidplatten (35° Winkel). Für Klemmhalter mit negativen Wendschneidplatten, siehe MVJN-K (Seite: A89).

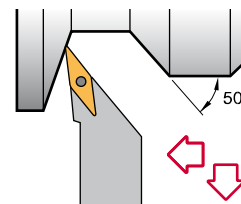

SVJC 93°

Reference Bezeichnung	h=h1	b	L1	L2	f	Insert size Wendschneidplatte	Kg
SVJC R/L 1212 F11	12	12	80	20	16	VC.. 1103..	0,100
SVJC R/L 1616 H11	16	16	100	25	20	VC.. 1103..	0,200
SVJC R/L 2020 K11	20	20	125	28	25	VC.. 1103..	0,400
SVJC R/L 2525 M11	25	25	150	28	32	VC.. 1103..	0,700
SVJC R/L 2020 K16	20	20	125	34	25	VC.. 1604..	0,400
SVJC R/L 2525 M16	25	25	150	34	32	VC.. 1604..	0,700
SVJC R/L 3225 P16	32	25	170	34	32	VC.. 1604..	0,900

Reference Bezeichnung					Nm
SVJC R/L 1212 F11	1225	5507	-	-	0.9
SVJC R/L 1616 H11	1225	5507	-	-	0.9
SVJC R/L 2020 K11	1225	5507	-	-	0.9
SVJC R/L 2525 M11	1225	5507	-	-	0.9
SVJC R/L 2020 K16	1335	5516	3718	1750	3.0
SVJC R/L 2525 M16	1335	5516	3718	1750	3.0
SVJC R/L 3225 P16	1335	5516	3718	1750	3.0

VC.. 35° rhombic positive inserts with 7° clearance. A48
35° rhombische positive Wendschneidplatten mit 7° Freiwinkel.

Reference / Bez.	l	s	d
VC.. 1103..	11,00	3,18	6,35
VC.. 1604..	16,50	4,76	9,52

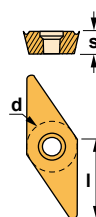

VCGT-AL



VCGT-AP



VCMT



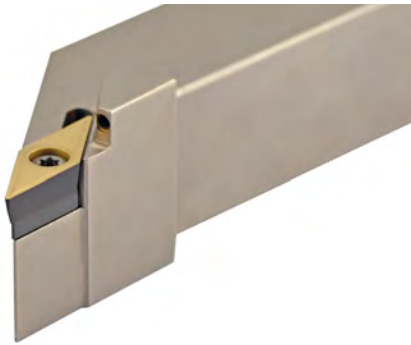

Characteristics:

Multipurpose profiling toolholder equipped with rhombic positive insert (angle 35°). For toolholders with negative inserts see Ref. MVJN-K (Page: A89).

Axial 0°
Radial 0°

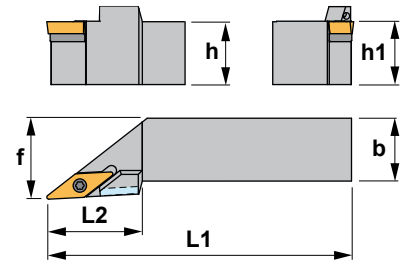

Eigenschaften:

Multifunktions-Klemmhalter zum Profildrehen mit rhombischen positiven Wendeschneidplatten (35° Winkel). Für Klemmhalter mit negativen Wendeschneidplatten, siehe MVJN-K (Seite: A89).

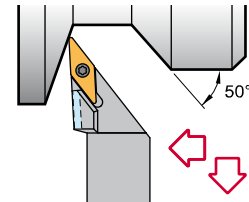

SVJC 93°-A

Reference Bezeichnung	h=h1	b	L1	L2	f	Insert size Wendeschneidplatte	
SVJC R/L 2020 K11-A	20	20	125	28	25	VC.. 1103..	0,400
SVJC R/L 2020 K16-A	20	20	125	34	25	VC.. 1604..	0,400
SVJC R/L 2525 M16-A	25	25	150	34	32	VC.. 1604..	0,700

Reference Bezeichnung								Nm
SVJC R/L 2020 K11-A	1225	5507	-	-	1506	1592	1598	0.9
SVJC R/L 2020 K16-A	1335	5516	3718	1750	1506	1592	1598	3.0
SVJC R/L 2525 M16-A	1335	5516	3718	1750	1506	1592	1598	3.0

VC.. 35° rhombic positive inserts with 7° clearance. A48
35° rhombische positive Wendeschneidplatten mit 7° Freiwinkel.

Reference / Bez.	l	s	d
VC.. 1103..	11,00	3,18	6,35
VC.. 1604..	16,50	4,76	9,52

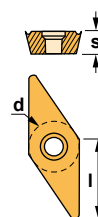

VCGT-AL **VCGT-AP**



VCMT





Characteristics:
Multipurpose profiling toolholder equipped with rhombic positive insert (angle 35°).
For general applications, roughing, semi-finishing and finishing.

Axial 0°
Radial 0°

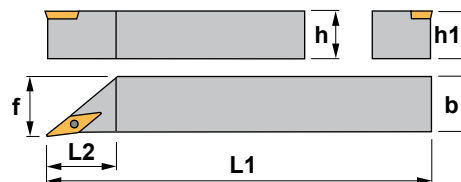

Eigenschaften:
Multifunktions-Klemmhalter zum Profildrehen mit rhombischen positiven Wendeschneidplatten (35° Winkel).
Für allgemeine Anwendungen geeignet (Schlichten, Medium und Schruppen).

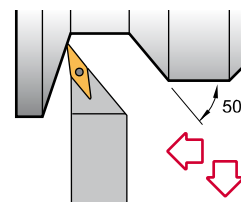

SVJC 93°

i Automatic lathes
Drehautomaten

Reference Bezeichnung	h=h1	b	L1	L2	f	Insert size Wendeschneidplatte	kg
SVJC R/L 0808 M11	8	8	150	26	8	VC.. 1103..	0,070
SVJC R/L 1010 M11	10	10	150	26	10	VC.. 1103..	0,100
SVJC R/L 1212 M11	12	12	150	26	12	VC.. 1103..	0,140
SVJC R/L 1616 M11	16	16	150	26	16	VC.. 1103..	0,270
SVJC R/L 1212 M16	12	12	150	40	12	VC.. 1604..	0,140
SVJC R/L 1616 M16	16	16	150	40	16	VC.. 1604..	0,270

Reference Bezeichnung			Nm
SVJC R/L 0808 M11	1225	5507	0.9
SVJC R/L 1010 M11	1225	5507	0.9
SVJC R/L 1212 M11	1225	5507	0.9
SVJC R/L 1616 M11	1225	5507	0.9
SVJC R/L 1212 M16	1240	5515	3.0
SVJC R/L 1616 M16	1240	5515	3.0

VC.. 35° rhombic positive inserts with 7° clearance. **i** A48
35° rhombische positive Wendeschneidplatten mit 7° Freiwinkel.

Reference / Bez.	l	s	d
VC.. 1103..	11,00	3,18	6,35
VC.. 1604..	16,50	4,76	9,52

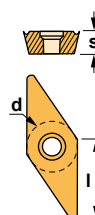

VCGT-AL



VCGT-AP



VCMT





Characteristics:

Multipurpose profiling toolholder equipped with rhombic positive insert (angle 35°).
For general applications, semi-finishing and finishing.

Axial 0°
Radial 0°

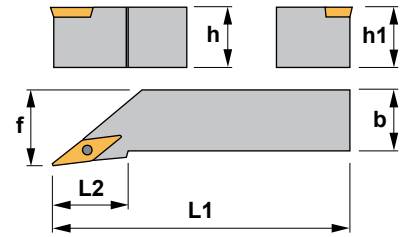

Eigenschaften:

Multifunktions-Klemmhalter zum Profildrehen mit positiven rhombischen Wendschneidplatten (35° Winkel).

Für allgemeine Anwendungen, Schruppen, Vorschlichten und Schlichten.

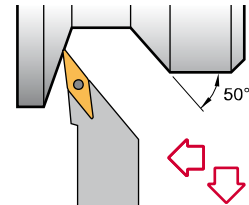

SVLC 95°

Reference Bezeichnung	h=h1	b	L1	L2	f	Insert size Wendschneidplatte	Kg
SVLC R/L 1212 G13	12	12	90	25	16	VCMT 1303..	0,100
SVLC R/L 1616 H13	16	16	100	25	20	VCMT 1303..	0,200
SVLC R/L 2020 K13	20	20	125	28	25	VCMT 1303..	0,400
SVLC R/L 2525 M13	25	25	150	28	32	VCMT 1303..	0,700

Reference Bezeichnung			Nm
SVLC R/L 1212 G13	1230	5508	1.2
SVLC R/L 1616 H13	1230	5508	1.2
SVLC R/L 2020 K13	1230	5508	1.2
SVLC R/L 2525 M13	1230	5508	1.2

VCMT

35° rhombic positive insert with 7° clearance. A48
35° rhombische positive Wendschneidplatte mit 7° Freiwinkel.

Reference / Bez.	l	s	d
VCMT 1303..	13,00	3,18	8,00

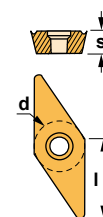

VCMT





Characteristics:

Multipurpose profiling toolholder equipped with rhombic 5° positive insert (angle 35°). For toolholders with negative inserts see Ref. MVVN-K (Page: A91).

Axial 0°
Radial 0°

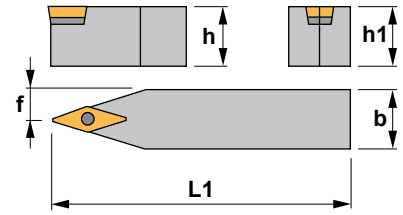



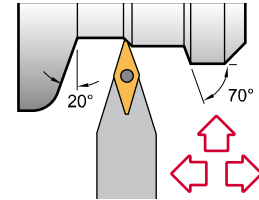

Eigenschaften:

Multifunktions-Klemmhalter zum Profildrehen mit 5° rhombischen positiven Wendeschneidplatten (35° Winkel). Für Klemmhalter mit negativen Wendeschneidplatten, siehe MVVN-K (Seite: A91).



SVVB 72°30'

Reference Bezeichnung	h=h1	b	L1	f	Insert size Wendeschneidplatte	kg
SVVB N 2020 K16	20	20	125	10,6	VBMT 1604..	0,400
SVVB N 2525 M16	25	25	150	13,1	VBMT 1604..	0,700
SVVB N 3225 P16	32	25	170	13,1	VBMT 1604..	0,900

Reference Bezeichnung					Nm
SVVB N 2020 K16	1335	5516	3718	1750	3.0
SVVB N 2525 M16	1335	5516	3718	1750	3.0
SVVB N 3225 P16	1335	5516	3718	1750	3.0

VBMT

35° rhombic positive insert with 5° clearance.  A48
35° rhombische positive Wendeschneidplatte mit 5° Freiwinkel.

Reference / Bez.	l	s	d
VBMT 1604..	16,50	4,76	9,52

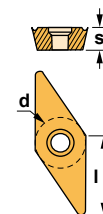

VBMT





Characteristics:

Multipurpose profiling toolholder equipped with rhombic positive insert (angle 35°). For toolholders with negative inserts see Ref. MVVN-K (Page: A91).

Axial 0°
Radial 0°

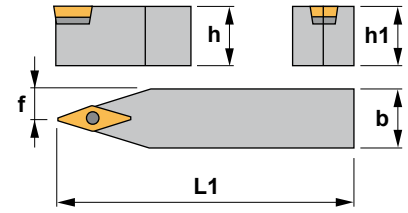

Eigenschaften:

Multifunktions-Klemmhalter zum Profildrehen mit rhombischen positiven Wendeschneidplatten (35° Winkel).

Für Klemmhalter mit negativen Wendeschneidplatten, siehe MVVN-K (Seite: A91).

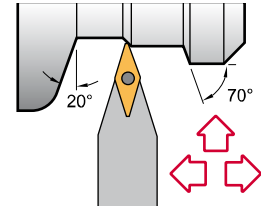

SVVC 72°30'

Reference Bezeichnung	h=h1	b	L1	f	Insert size Wendeschneidplatte	
SVVC N 1212 F11	12	12	80	6,6	VC.. 1103..	0,100
SVVC N 1616 H11	16	16	100	8,6	VC.. 1103..	0,200
SVVC N 2020 K11	20	20	125	10,6	VC.. 1103..	0,400
SVVC N 2020 K16	20	20	125	10,6	VC.. 1604..	0,400
SVVC N 2525 M16	25	25	150	13,1	VC.. 1604..	0,700
SVVC N 3225 P16	32	25	170	13,1	VC.. 1604..	0,900

Reference Bezeichnung					Nm
SVVC N 1212 F11	1225	5507	-	-	0.9
SVVC N 1616 H11	1225	5507	-	-	0.9
SVVC N 2020 K11	1225	5507	-	-	0.9
SVVC N 2020 K16	1335	5516	3718	1750	3.0
SVVC N 2525 M16	1335	5516	3718	1750	3.0
SVVC N 3225 P16	1335	5516	3718	1750	3.0

VC.. 35° rhombic positive inserts with 7° clearance. A48
35° rhombische positive Wendeschneidplatten mit 7° Freiwinkel.

Reference / Bez.	l	s	d
VC.. 1103..	11,00	3,18	6,35
VC.. 1604..	16,50	4,76	9,52

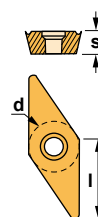

VCGT-AL



VCGT-AP



VCMT



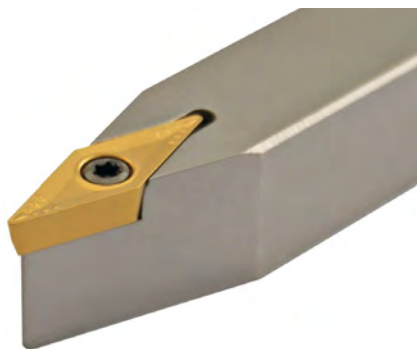

Characteristics:
Multipurpose profiling toolholder equipped with rhombic 5° positive insert (angle 35°).
For general applications, roughing, semi-finishing and finishing.

Axial 0°
Radial 0°

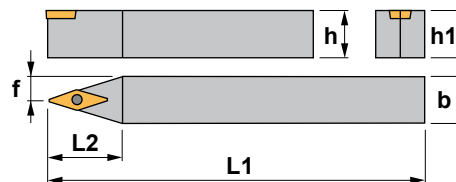

Eigenschaften:
Multifunktions-Klemmhalter zum Profildrehen mit 5° rhombischen positiven Wendeschneidplatten (35° Winkel).
Für allgemeine Anwendungen geeignet (Schlichten, Medium und Schruppen).

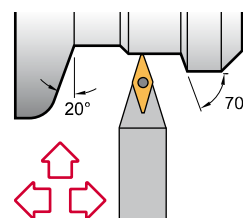

SVVC 72°30'

i Automatic lathes
Drehautomaten

Reference Bezeichnung	h=h1	b	L1	L2	f	Insert size Wendeschneidplatte	Kg
SVVC N 0808 M11	8	8	150	21	4,3	VC.. 1103..	0,070
SVVC N 1010 M11	10	10	150	21	5,3	VC.. 1103..	0,100
SVVC N 1212 M11	12	12	150	21	6,3	VC.. 1103..	0,140
SVVC N 1616 M11	16	16	150	21	8,3	VC.. 1103..	0,260

Reference Bezeichnung			Nm
SVVC N 0808 M11	1225	5507	0.9
SVVC N 1010 M11	1225	5507	0.9
SVVC N 1212 M11	1225	5507	0.9
SVVC N 1616 M11	1225	5507	0.9

VC.. 35° rhombic positive inserts with 7° clearance. **i** A48
35° rhombische positive Wendeschneidplatten mit 7° Freiwinkel.

Reference / Bez.	l	s	d
VC.. 1103..	11,00	3,18	6,35

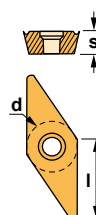

VCGT-AL



VCGT-AP



VCMT



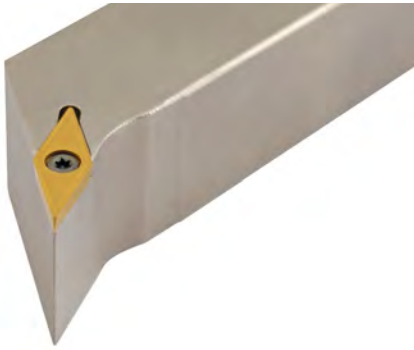

Characteristics:

Multipurpose profiling toolholder equipped with rhombic positive insert (angle 35°). For general applications, semi-finishing and finishing.

Axial 0°
Radial 0°

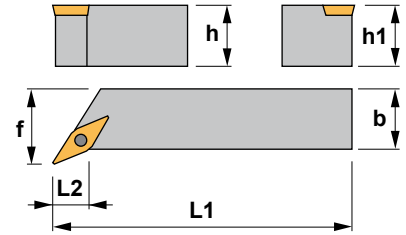

Eigenschaften:

Multifunktions-Klemmhalter zum Profildrehen mit rhombischen positiven Wendeschneidplatten (35° Winkel).

Für allgemeine Anwendungen, Schruppen, Vorschlichten und Schlichten.

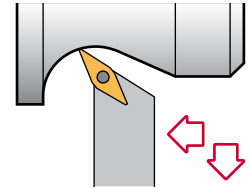

SVXC 113°

Reference Bezeichnung	h=h1	b	L1	L2	f	Insert size Wendeschneidplatte	Kg
SVXC R/L 1212 G13	12	12	90	11,5	16	VCMT 1303..	0,100
SVXC R/L 1616 H13	16	16	100	13,8	20	VCMT 1303..	0,200
SVXC R/L 2020 K13	20	20	125	28,0	25	VCMT 1303..	0,400
SVXC R/L 2525 M13	25	25	150	28,0	32	VCMT 1303..	0,700

Reference Bezeichnung			Nm
SVXC R/L 1212 G13	1230	5508	1.2
SVXC R/L 1616 H13	1230	5508	1.2
SVXC R/L 2020 K13	1230	5508	1.2
SVXC R/L 2525 M13	1230	5508	1.2

VCMT

35° rhombic positive insert with 7° clearance. A48
35° rhombische positive Wendeschneidplatte mit 7° Freiwinkel.

Reference / Bez.

l

s

d

VCMT 1303..

13,00

3,18

8,00

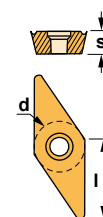

VCMT





Characteristics:

Multipurpose profiling toolholder equipped with rhombic positive insert (angle 35°). For general applications, semi-finishing and finishing.

Axial 0°
Radial 0°

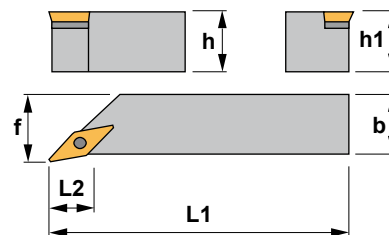

Eigenschaften:

Multifunktions-Klemmhalter zum Profildrehen mit rhombischen positiven Wendeschneidplatten (35° Winkel).

Für allgemeine Anwendungen, Schruppen, Vorschlichten und Schlichten.

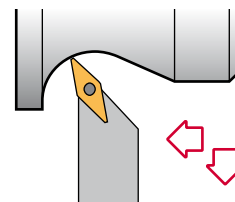

SVZC 100°

Reference Bezeichnung	h=h1	b	L1	L2	f	Insert size Wendeschneidplatte	Kg
SVZC R/L 2020 K16	20	20	125	28	25	VC.. 1604..	0,400
SVZC R/L 2525 M16	25	25	150	34	32	VC.. 1604..	0,700
SVZC R/L 3225 P16	32	25	170	34	32	VC.. 1604..	0,900

Reference Bezeichnung					Nm
SVZC R/L 2020 K16	1335	5516	3718	1750	3.0
SVZC R/L 2525 M16	1335	5516	3718	1750	3.0
SVZC R/L 3225 P16	1335	5516	3718	1750	3.0

VC.. 35° rhombic positive inserts with 7° clearance. A48
35° rhombische positive Wendeschneidplatten mit 7° Freiwinkel.

Reference / Bez.	l	s	d
VC.. 1604..	16,50	4,76	9,52

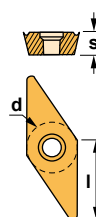

Nominal cutting speed and feed values for toolholders

Material	P	HB	Condition	Cutting speed m/min.						Specific cutting force Kc 0,4
				PM25	PM40	NC25	TN15	TN20	TN30	
				0.3-0.6-1.2		0.1-0.3	0.1-0.4-0.8	0.1-0.4-0.8	0.2-0.5-1.2	
Unalloyed steel	125	C=0.15%	150 115 80		350 280	480 345 250	440 300 205	330 230 110	1900	
	150	C=0.35%	145 105 70		270 230	440 315 230	400 275 190	300 210 150	2100	
	200	C=0.60%	115 90 65		240 190	385 275 200	350 240 165	260 185 130	2250	
Low alloyed steel	180	Annealed	90 70 45		300 260	380 265 195	320 220 170	200 140 100	2100	
	275	Hardened	65 45 30		220 140	260 180 130	215 150 115	140 100 70	2600	
	300	Hardened	60 40 25		230 180	240 165 120	200 135 105	125 90 60	2700	
	350	Hardened	50 35 20		220 140	210 145 105	170 120 90	110 75 55	2850	
High alloyed steel	200	Annealed	80 60 45		200 160	350 230 170	280 185 135	175 115 80	2600	
	325	Hardened	40 25 20		200 160	170 110	120 80 60	85 55 40	3900	
Stainless steel	200	Martensitic / ferritic	110 95 75		270 130	295 240 190	275 210 165	225 180 145	2300	
Steel castings	180	Unalloyed	60 50 35		300 260	260 185 145	230 160 120	135 105 75	2000	
	200	Low alloyed	50 45 30		230 180	230 160 120	190 125 85	120 90 60	2500	
	225	High alloyed	40 30 20		220 140	190 130 95	170 115 80	95 70 55	2700	

Material	M	HB	Condition	Cutting speed m/min.						Specific cutting force Kc 0,4		
				PM25	NC25	TN15	TN20	TN30	TN35		TS15	TS20
				0.1-0.3	0.1-0.3	0.1-0.4-0.8		0.2-0.4-0.6	0.2-0.4-0.6		0.1-0.3	
Stainless steel annealed	180	Austenitic Ni > 8%, Cr 12-25% austenitic/ferritic, austenitic/ferritic, low S	240 200 160 130 160 130	180 150 120 180 150 120 180 150 120			190 160 130 190 160 130 140 110	190 160 130 190 160 130 160 130 100	240 200 160 130 160 130	120 180 130 220 120 180	2450	

Material	K	HB	Condition	Cutting speed m/min.						Specific cutting force Kc 0,4
				KM15	NC25	TN15	TN20	TK15	ZR10	
				0.2-0.5-1.0	0.2-0.5	0.2-0.5-1.0		0.2-0.5-1.0	0.2-0.5-1.0	
Hardened steel	350	Hardened steel	27 16 10		175 145 100			180 150 110		4500
	250	Manganese steel 12%	65 40 16		120 85 50			120 90 60		3600
Malleable cast iron	130	Ferritic	105 75 45		225 150 90			250 180 100		1100
	230	Pearlitic	80 60 30		155 95 55			160 100 60		1100
Cast iron	180	Low tensile strength	135 95 60	300 200	165 110 70			180 120 80		1100
	260	High tensile strength	95 65 40	250 180	120 90 55			140 105 60		1500
Nodular SG iron	160	Ferritic	115 80 45	250 180				220 180 100		1100
	250	Pearlitic	80 50 30	180 120				150 100 50		1800
Chilled cast iron	400		17 11					17 11		3000

Material	N	HB	Condition	Cutting speed m/min.						Specific cutting force Kc 0,4
				KM15	TK15	NC25	TN15	TN20	ZR10	
				0.2-0.5-1.0	0.2-0.5-1.0	0.2-0.5	0.2-0.5-1.0		0.2-0.5-1.0	
Aluminium alloys	60	Non heat treatable	1750 1280 800						1750 1280 800	500
	100	Heat treatable	510 370 250						510 370 250	800
Aluminium alloys (cast)	75	Non heat treatable	460 285 175						460 285 175	750
	90	Heat treatable	300 180 110						300 180 110	900
Bronze-brass alloys	110	Lead alloys, Pb>1%	610 430 295						610 430 295	700
	90	Brass and bronze	310 250 195						310 250 195	750
	100	Inc. electrolytic copper	225 160 115						225 160 115	1750
Other materials		Hard plastics	380 240						380 240	
		Fibre	190 120						190 120	
		Hard rubber	225 160						225 160	

Material	S	HB	Condition	Cutting speed m/min.						Specific cutting force Kc 0,4
				KM15	NC25	TN15	TS15	TS20	ZR10	
				0.2-0.5-1.0	0.2-0.5	0.2-0.5-1.0			0.2-0.5-1.0	
Heat-resistant alloys			Fe-base					80 120		
			Nickel or cobalt base					60 100		
			Nickel or cobalt base					35 90		
			Nickel or cobalt base					30 50		
Titanium alloys			Titanium					70 120		



Nennschnittgeschwindigkeit und Vorschub-Werte für Klemmhalter

Materialien	P	HB	Beschaffenheit	Schnittgeschwindigkeit m/min.					Spezifische Schnittkraft Kc 0,4	
				PM25	PM40	NC25	TN15	TN20		TN30
				0.3-0.6-1.2		0.1-0.3	0.1-0.4-0.8	0.1-0.4-0.8		0.2-0.5-1.2
Unlegierter Stahl	125	C=0.15% C=0.35% C=0.60%		150 115 80		350 280	480 345 250	440 300 205	330 230 110	1900
	150			145 105 70		270 230	440 315 230	400 275 190	300 210 150	2100
	200			115 90 65		240 190	385 275 200	350 240 165	260 185 130	2250
Niedriglegierter Stahl	180	Geglüht Vergütet Vergütet Vergütet		90 70 45		300 260	380 265 195	320 220 170	200 140 100	2100
	275			65 45 30		220 140	260 180 130	215 150 115	140 100 70	2600
	300			60 40 25		230 180	240 165 120	200 135 105	125 90 60	2700
	350			50 35 20		220 140	210 145 105	170 120 90	110 75 55	2850
Hochlegierter Stahl	200	Geglüht Vergütet		80 60 45		200 160	350 230 170	280 185 135	175 115 80	2600
	325			40 25 20		200 160	170 110	120 80 60	85 55 40	3900
Rostfreier Stahl	200	Martensitisch/ Ferritisch		110 95 75		270 130	295 240 190	275 210 165	225 180 145	2300
Stahlguß	180	Unlegiert Niedriglegiert Hochlegiert		60 50 35		300 260	260 185 145	230 160 120	135 105 75	2000
	200			50 45 30		230 180	230 160 120	190 125 85	120 90 60	2500
	225			40 30 20		220 140	190 130 95	170 115 80	95 70 55	2700

Materialien	M	HB	Beschaffenheit	Schnittgeschwindigkeit m/min.					Spezifische Schnittkraft Kc 0,4			
				PM25	NC25	TN15	TN20	TN30		TN35	TS15	TS20
				0.1-0.3	0.1-0.3	0.1-0.4-0.8		0.2-0.4-0.6		0.2-0.4-0.6	0.1-0.3	
Rostfreier Stahl, geglüht	180	Austenitisch Ni > 8%, Cr 12-25% Austenitisch/ Ferritisch, Austenitisch/ Ferritisch, niedriger S-Anteil		240 200	180 150 120			190 160 130	190 160 130	240 200	120 180	2450
				160 130	180 150 120			190 160 100	190 160 130	160 130	130 220	
				160 130	180 150 120			140 110	160 130 100	160 130	120 180	

Materialien	K	HB	Beschaffenheit	Schnittgeschwindigkeit m/min.					Spezifische Schnittkraft Kc 0,4	
				KM15	NC25	TN15	TN20	TK15		ZR10
				0.2-0.5-1.0	0.2-0.5	0.2-0.5-1.0		0.2-0.5-1.0		0.2-0.5-1.0
Gehärteter Stahl	350 250	Vergüteter Stahl Mangan-Stahl 12%		27 16 10		175 145 100		180 150 110		4500
				65 40 16		120 85 50		120 90 60		3600
Temperguß	130 230	Ferritisch Perlitisch		105 75 45		225 150 90		250 180 100		1100
				80 60 30		155 95 55		160 100 60		1100
Guß	180 260	Niedrige Zugfestigkeit Hohe Zugfestigkeit		135 95 60	300 200	165 110 70		180 120 80		1100
				95 65 40	250 180	120 90 55		140 105 60		1500
SG-Kugelgraphitguß	160 250	Ferritisch Perlitisch		115 80 45	250 180			220 180 100		1100
				80 50 30	180 120			150 100 50		1800
Kaltverfestigender Guß	400			17 11				17 11		3000

Materialien	N	HB	Beschaffenheit	Schnittgeschwindigkeit m/min.					Spezifische Schnittkraft Kc 0,4	
				KM15	TK15	NC25	TN15	TN20		ZR10
				0.2-0.5-1.0	0.2-0.5-1.0	0.2-0.5	0.2-0.5-1.0			0.2-0.5-1.0
Aluminium-Legierungen	60 100	Nicht wärmebehandelbar Wärmebehandelbar		1750 1280 800					1750 1280 800	500
				510 370 250					510 370 250	800
Gegossene Aluminium-Legierungen	75 90	Nicht wärmebehandelbar Wärmebehandelbar		460 285 175					460 285 175	750
				300 180 110					300 180 110	900
Bronze- und Messinglegierungen	110 90 100	Bleilegierungen, Pb>1% Messing, Bronze Elektrolytkupfer		610 430 295					610 430 295	700
				310 250 195					310 250 195	750
				225 160 115					225 160 115	1750
Andere Materialien		Hartkunststoff Faser Hartgummi		380 240					380 240	
				190 120					190 120	
				225 160					225 160	

Materialien	S	HB	Beschaffenheit	Schnittgeschwindigkeit m/min.					Spezifische Schnittkraft Kc 0,4	
				KM15	NC25	TN15	TS15	TS20		ZR10
				0.2-0.5-1.0	0.2-0.5	0.2-0.5-1.0				0.2-0.5-1.0
Wärmefeste Legierungen			Fe-Basis Nickel- und Kobalthaltig Nickel- und Kobalthaltig Nickel- und Kobalthaltig					80 120		
								60 100		
								35 90		
								30 50		
Titan-Legierungen			Titan				70 120			

