

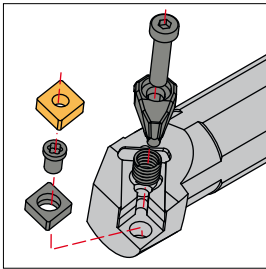

BORING BARS

Clamping systems	A138
Code system (ISO)	A139
Applications index	A140-141
Dimple lock boring bars	A142-143
Double lock boring bars	A144-155
Wedge clamp boring bars	A156-158
Top clamp boring bars	A159-160
Center screw boring bars	A161-170
Anti-vibration tools	A171-183
Cutting data	A184-185



(D) Dimple lock

The "D" clamping system avoids insert movement during high feed or heavily interrupted machining, due to its accurate indexing that holds the insert securely clamped.

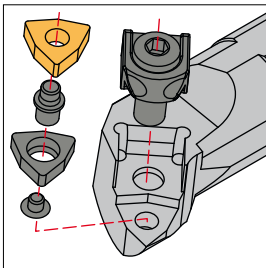

(W) Wedge clamp

Negative inserts require good clamping force for heavy duty work, for this purpose we have designed our "W" system, one of the strongest and safest available.

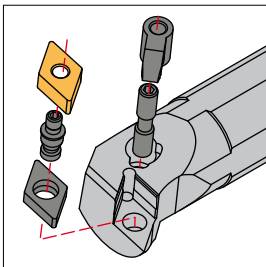

(M) Double lock

The double lock system offers good rigidity in negative inserts clamping. It is the first choice for center hole negative ceramic and cermet inserts.

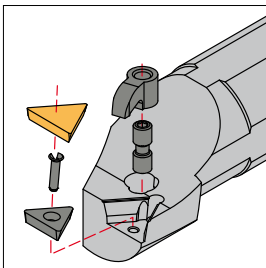

(C) Top clamp

The classic positive insert clamping system is designed to hold flat positive inserts, both with additional or sintered chipbreaker.

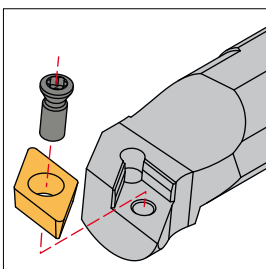

(S) Center screw

Since the advent of the TORX screw it has been possible to hold with complete safety positive inserts with center hole. Our range covers all the screw fixing permutations.





Code system (ISO)

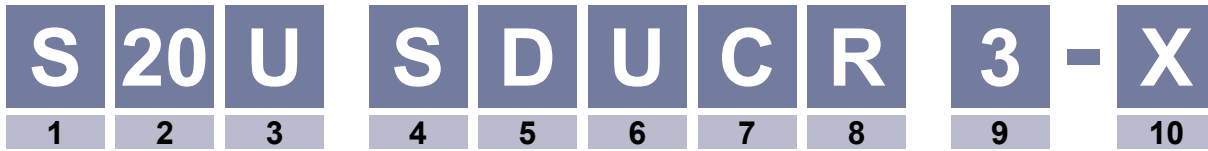

1 Type of bar

A	Steel shank with internal coolant.	
S	Steel shank	

2 Bar diameter, inch.

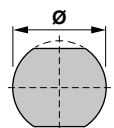

06	0.375	20	1.250
08	0.500	24	1.500
10	0.625	28	1.750
12	0.750	32	2.000
16	1.000	40	2.500

3 Bar length, inch.

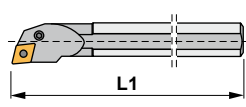

H	4.0	S	10.0
J	4.5	T	12.0
K	5.0	U	14.0
M	6.0	V	16.0
R	8.0		

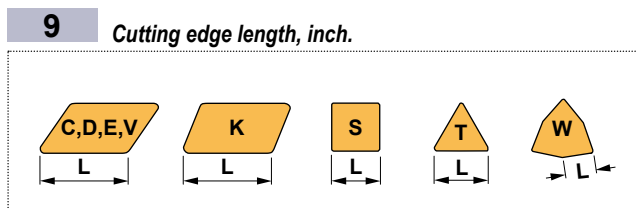
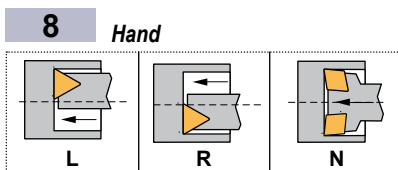
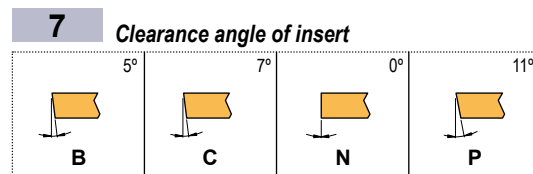
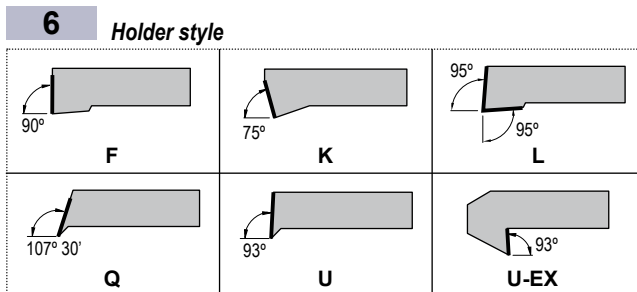
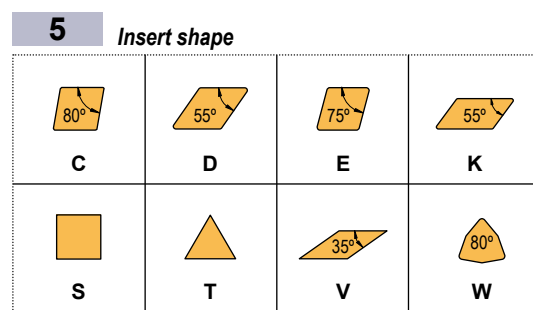
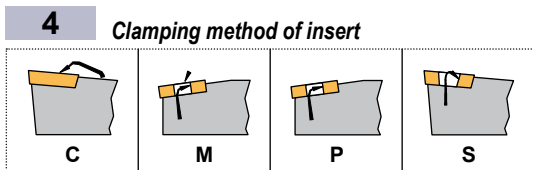

10
Manufacturer's option.



NEGATIVE BORING BARS

Dimple lock boring bars

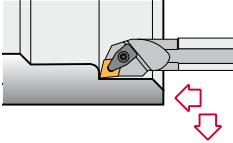
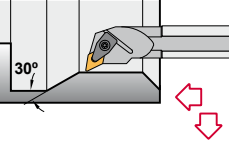
<p>DCLN 95°-N</p>  <p>Page A142 CN..43..</p>	<p>DDUN 93°-N</p>  <p>Page A143 DN..43..</p>			
---	---	--	--	--

Double lock boring bars

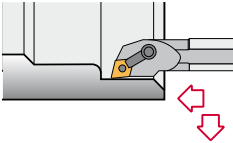
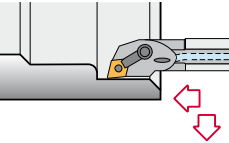
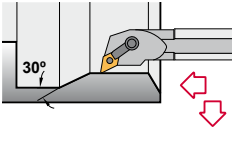
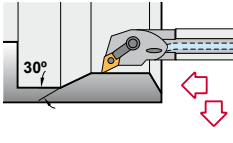
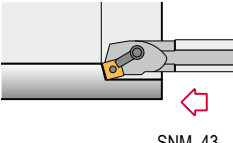
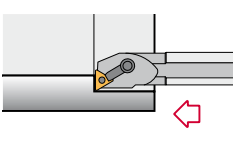
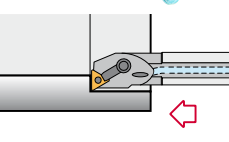
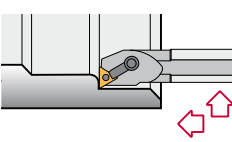
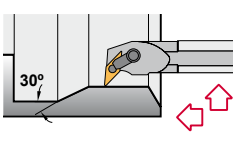
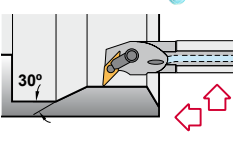
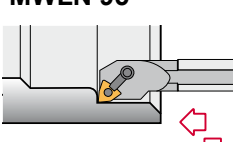
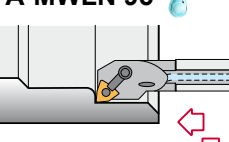
<p>MCLN 95°</p>  <p>Page A144 CN..43.. CN..64..</p>	<p>A-MCLN 95°</p>  <p>Page A145 CN..43.. CN..64..</p>	<p>MDUN 93°</p>  <p>Page A146 DN..43.. DN..54..</p>	<p>A-MDUN 93°</p>  <p>Page A147 DN..43..</p>	<p>MSKN 75°</p>  <p>Page A148 SNM..43.. SNM..54.. SNM..64..</p>
<p>MTFN 90°</p>  <p>Page A149 TNM..33.. TNM..54..</p>	<p>A-MTFN 90°</p>  <p>Page A150 TNM..33.. TNM..43..</p>	<p>MTUN 93°</p>  <p>Page A151 TNM..33.. TNM..43..</p>	<p>MVUN 93°</p>  <p>Page A152 VN..33.. VN..43..</p>	<p>A-MVUN 93°</p>  <p>Page A153 VN..33..</p>
<p>MWLN 95°</p>  <p>Page A154 WNMG43..</p>	<p>A-MWLN 95°</p>  <p>Page A155 WNMG33.. WNMG43..</p>			

Wedge clamp

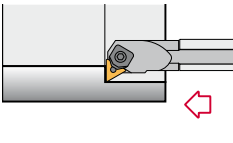
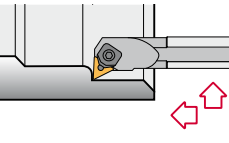
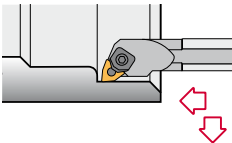
<p>WTFN 90°</p>  <p>Page A156 TNM..33.. TNM..43..</p>	<p>WTUN 93°</p>  <p>Page A157 TNM..33.. TNM..43..</p>	<p>WWLN 95°</p>  <p>Page A158 WNM..33.. WNM..43..</p>		
--	--	--	--	--







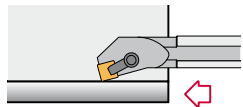
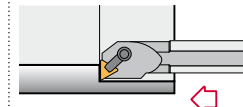

POSITIVE BORING BARS

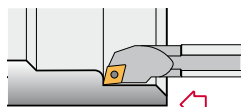

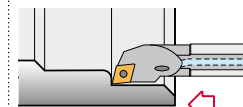
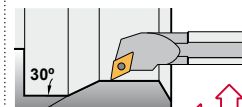

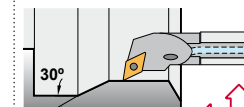
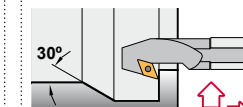
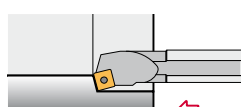
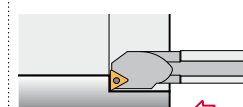

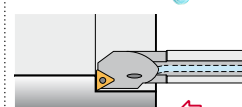
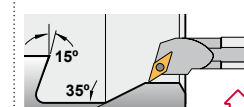
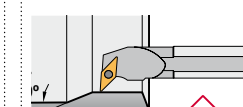







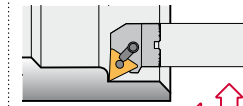

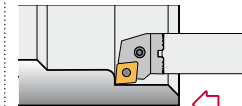

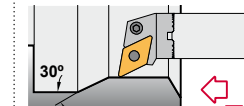
Top clamp boring bars

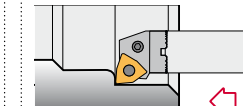
<p>CSKP 75°</p>  <p>Page A159 SP.42.. SP.63..</p>	<p>CTFP 90°</p>  <p>Page A160 TP.32.. TP.43..</p>			
--	--	--	--	--

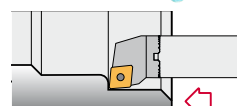
Center screw boring bars

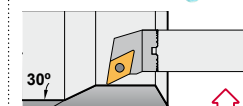
<p>SCLC 95°</p>  <p>CC..21.5.. CC..32.5.. CC..43.. Page A161</p>	<p>A-SCLC 95° </p>  <p>Page A162 CC..21.5.. CC..32.5..</p>	<p>SDUC 93°</p>  <p>Page A163 DC..21.5.. DC..32.5..</p>	<p>A-SDUC 93° </p>  <p>Page A164 DC..21.5.. DC..32.5..</p>	<p>SDUC 93°-EX</p>  <p>Page A165 DC..21.5.. DC..32.5..</p>
<p>SSKC 75°</p>  <p>Page A166 SC..32.5..</p>	<p>STFC 90°</p>  <p>Page A167 TC..21.5.. TC..32.5..</p>	<p>A-STFC 90° </p>  <p>Page A168 TC..21.5..</p>	<p>SVQC 107°30'</p>  <p>Page A169 VC..33..</p>	<p>SVUC 93°</p>  <p>Page A170 VC..22.. VC..33..</p>

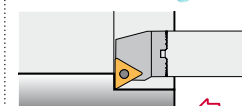
Anti-vibration tools

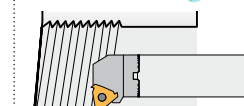
<p>J..  </p>  <p>Page A175</p>	<p>MTUN 93°-N </p>  <p>Page A176 TNM..33.. TNM..43..</p>	<p>PCLN 95°-N </p>  <p>Page A177 CN..43.. CN..54..</p>	<p>PDUN 93°-N </p>  <p>Page A178 DN..43.. DN..44..</p>	<p>PWLN 95°-N </p>  <p>Page A179 WNMG43..</p>
<p>SCLC 95°-N </p>  <p>Page A180 CC..32.5.. CC..43..</p>	<p>SDUC 93°-N </p>  <p>Page A181 DC..32.5..</p>	<p>STFC 90°-N </p>  <p>Page A182 TC..32.5..</p>	<p>STXN 90°-N </p>  <p>Page A183 16NR/L.. 22NR/L..</p>	



Characteristics:

Boring bar for internal turning applications equipped with rhombic negative inserts (angle 80°).

For low powered machines and small pieces choose boring bars Ref. SCLC (Page: A161).

Axial -5°
Radial -13.5°

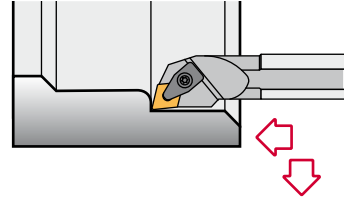
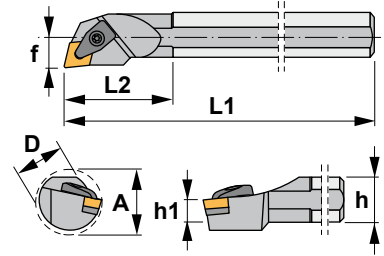

DCLN 95°-N

Reference	D	h	h1	L1	L2	f	A	Insert size	
S16T-DCLNR/L4N	1.000	0.900	0.450	12.00	1.575	0.640	1.280	CN..43..	0.700
S20U-DCLNR/L4N	1.250	1.180	0.590	14.00	1.771	0.765	1.530	CN..43..	2.050
S24U-DCLNR/L4N	1.500	1.370	0.685	14.00	1.968	0.890	1.780	CN..43..	3.750

Reference							Nm
S16T-DCLNR/L4N	ICSN-422	1766	2712	1696	4295	5004	3.5
S20U-DCLNR/L4N	ICSN-442	1766	2712	1696	4295	5004	3.5
S24U-DCLNR/L4N	ICSN-442	1766	2712	1696	4295	5004	3.5

CN.. 80° rhombic negative inserts. A24-26																												
Reference	l	T	d																									
CN..43..	0.508	0.187	0.500	<table border="0"> <tr> <td></td> <td></td> <td></td> <td></td> <td></td> <td colspan="5"></td> </tr> <tr> <td></td> <td></td> <td></td> <td></td> <td></td> <td colspan="5"></td> </tr> </table>																								



Characteristics:

Boring bar for internal turning and profiling applications equipped with rhombic negative inserts (angle 55°).

For low powered machines and small pieces choose boring bars Ref. SDUC (Page: A163).

Axial -6°
Radial -14°

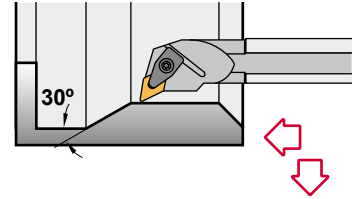
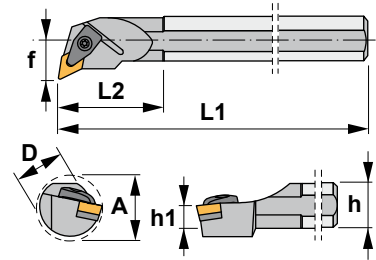

DDUN 93°-N

Reference	D	h	h1	L1	L2	f	A	Insert size	
S20U-DDUNR/L4N	1.250	1.180	0.590	14.00	1.771	0.765	1.530	DN..43..	2.050
S24U-DDUNR/L4N	1.500	1.370	0.685	14.00	1.968	0.890	1.780	DN..43..	3.750

Reference							Nm
S20U-DDUNR/L4N	IDSN-432	1766	2712	1696	4295	5004	3.5
S24U-DDUNR/L4N	IDSN-432	1766	2712	1696	4295	5004	3.5

DN..	55° rhombic negative inserts. A28-30		
Reference	l	T	d
DN..43..	0.610	0.187	0.500

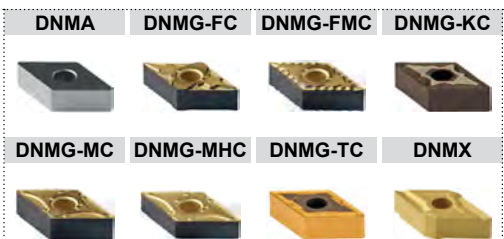



Characteristics:

Multipurpose boring bar equipped with rhombic negative double-sided insert (angle 80°).

For low powered machines and small pieces choose boring bars Ref. SCLC (Page: A161).

Axial -5°
Radial -13.5°

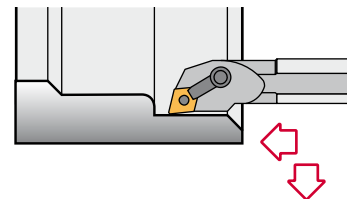
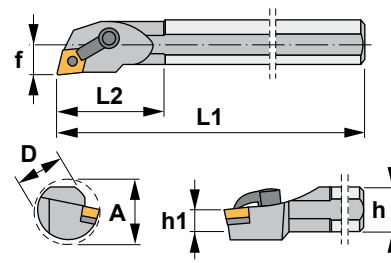

MCLN 95°

Reference	D	h	h1	L1	L2	f	A	Insert size	lbs
S16T-MCLNR/L4	1.000	0.900	0.450	12.00	2.50	0.640	1.280	CN..43..	1.540
S20U-MCLNR/L4	1.250	1.180	0.590	14.00	3.00	0.765	1.530	CN..43..	4.510
S24U-MCLNR/L4	1.500	1.370	0.685	14.00	3.00	0.890	1.780	CN..43..	8.250
S28U-MCLNR/L4	1.750	1.630	0.815	14.00	4.00	1.015	2.030	CN..43..	9.300
S32V-MCLNR/L4	2.000	1.870	0.935	16.00	4.00	1.281	2.562	CN..43..	13.750
S40V-MCLNR/L4	2.500	2.380	1.190	16.00	4.00	1.531	3.062	CN..43..	21.800
S32V-MCLNR/L5	2.000	1.870	0.935	16.00	4.00	1.281	2.562	CN..54..	13.750
S40V-MCLNR/L5	2.500	2.380	1.190	16.00	4.00	1.531	3.062	CN..54..	21.800
S32V-MCLNR/L6	2.000	1.870	0.935	16.00	4.00	1.281	2.562	CN..64..	13.750
S40V-MCLNR/L6	2.500	2.380	1.190	16.00	4.00	1.531	3.062	CN..64..	21.800

Reference							Nm ¹	Nm ²
S16T-MCLNR/L4	CL-20	XNS-47	5103	-	NL-44	5124	3.0	3.5
S20U-MCLNR/L4	CL-20	XNS-48	5103	ICSN-432	NL-46	5124	3.0	3.5
S24U-MCLNR/L4	CL-20	XNS-48	5103	ICSN-432	NL-46	5124	3.0	3.5
S28U-MCLNR/L4	CL-20	XNS-48	5103	ICSN-432	NL-46	5124	3.0	3.5
S32V-MCLNR/L4	CL-20	XNS-48	5103	ICSN-432	NL-46	5124	3.0	3.5
S40V-MCLNR/L4	CL-20	XNS-48	5103	ICSN-432	NL-46	5124	3.0	3.5
S32V-MCLNR/L5	CL-12	XNS-510	5004	ICSN-533	NL-58	5103	3.5	3.0
S40V-MCLNR/L5	CL-12	XNS-510	5004	ICSN-533	NL-58	5103	3.5	3.0
S32V-MCLNR/L6	CL-12	XNS-510	5004	ICSN-633	NL-68	5135	3.5	4.0
S40V-MCLNR/L6	CL-12	XNS-510	5004	ICSN-633	NL-68	5135	3.5	4.0

CN..

80° rhombic negative inserts. A24-26

Reference	l	T	d
CN..43..	0.508	0.187	0.500
CN..54..	0.633	0.250	0.625
CN..64..	0.763	0.250	0.750

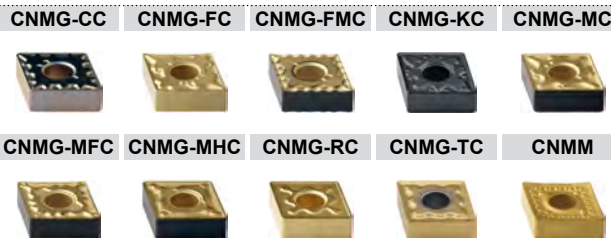
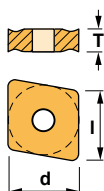



Characteristics:

Multipurpose boring bar equipped with rhombic negative double-sided insert (angle 80°).

For low powered machines and small pieces choose boring bars Ref. A-SCLC (Page: A162).

Axial -5°
Radial -13.5°

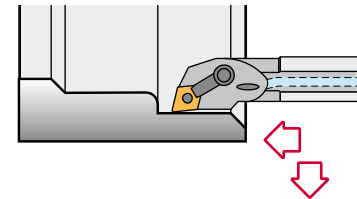
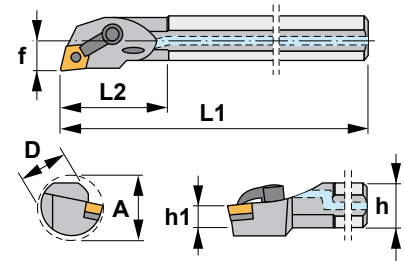

A-MCLN 95°

Reference	D	h	h1	L1	L2	f	A	Insert size	lbs
A16T-MCLNR/L4	1.000	0.900	0.450	12.00	2.50	0.640	1.280	CN..43..	1.540
A20U-MCLNR/L4	1.250	1.180	0.590	14.00	3.00	0.765	1.530	CN..43..	4.510
A24U-MCLNR/L4	1.500	1.370	0.685	14.00	3.00	0.890	1.780	CN..43..	8.250
A28U-MCLNR/L4	1.750	1.630	0.815	14.00	4.00	1.015	2.030	CN..43..	9.300
A32V-MCLNR/L5	2.000	1.870	0.935	16.00	4.00	1.281	2.562	CN..54..	13.750
A32V-MCLNR/L6	2.000	1.870	0.935	16.00	4.00	1.281	2.562	CN..64..	13.750

Reference							Nm ¹	Nm ²
A16T-MCLNR/L4	CL-20	XNS-47	5103	-	NL-44	5124	3.0	3.5
A20U-MCLNR/L4	CL-20	XNS-48	5103	ICSN-432	NL-46	5124	3.0	3.5
A24U-MCLNR/L4	CL-20	XNS-48	5103	ICSN-432	NL-46	5124	3.0	3.5
A28U-MCLNR/L4	CL-20	XNS-48	5103	ICSN-432	NL-46	5124	3.0	3.5
A32V-MCLNR/L5	CL-12	XNS-510	5004	ICSN-533	NL-58	5103	3.5	3.0
A32V-MCLNR/L6	CL-12	XNS-510	5004	ICSN-633	NL-68	5135	3.5	4.0

CN..

80° rhombic negative inserts. A24-26

Reference	l	T	d
CN..43..	0.508	0.187	0.500
CN..54..	0.633	0.250	0.625
CN..64..	0.763	0.250	0.750

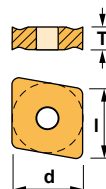



Characteristics:

Internal turning and profiling boring bar equipped with rhombic negative double-sided insert (angle 55°).

For low powered machines and small pieces choose boring bars Ref. SDUC (Page: A163).

Axial -6°
Radial -12°

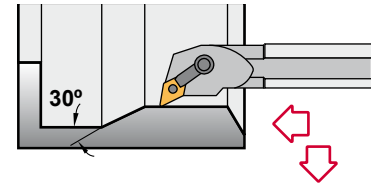
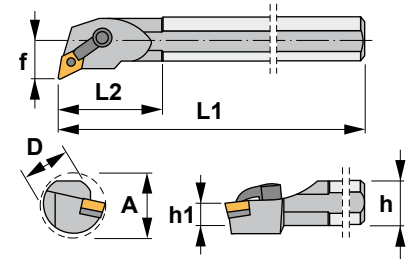

MDUN 93°

Reference	D	h	h1	L1	L2	f	A	Insert size	
S16T-MDUNR/L4	1.000	0.900	0.450	12.00	2.50	0.875	1.750	DN..43..	1.540
S20U-MDUNR/L4	1.250	1.180	0.590	14.00	3.00	1.000	2.000	DN..43..	4.510
S24U-MDUNR/L4	1.500	1.370	0.685	14.00	3.00	1.125	2.250	DN..43..	8.250
S32V-MDUNR/L4	2.000	1.870	0.935	16.00	4.00	1.375	3.000	DN..43..	13.750
S32V-MDUNR/L5	2.000	1.870	0.935	16.00	4.00	1.500	3.000	DN..54..	13.750
S40V-MDUNR/L5	2.500	2.380	1.190	16.00	4.00	1.750	3.500	DN..54..	21.800

Reference							Nm ¹	Nm ²
S16T-MDUNR/L4	CL-20	XNS-47	5103	-	NL-44	5124	3.0	3.5
S20U-MDUNR/L4	CL-20	XNS-48	5103	IDSN-432	NL-46	5124	3.0	3.5
S24U-MDUNR/L4	CL-20	XNS-48	5103	IDSN-432	NL-46	5124	3.0	3.5
S32V-MDUNR/L4	CL-20	XNS-48	5103	IDSN-432	NL-46	5124	3.0	3.5
S32V-MDUNR/L5	CL-12	XNS-510	5004	IDSN-533	NL-58	5103	3.5	3.0
S40V-MDUNR/L5	CL-12	XNS-510	5004	IDSN-533	NL-58	5103	3.5	3.0

DN..

55° rhombic negative inserts. A28-30

Reference	l	T	d
DN..43..	0.610	0.187	0.500
DN..54..	0.764	0.250	0.625

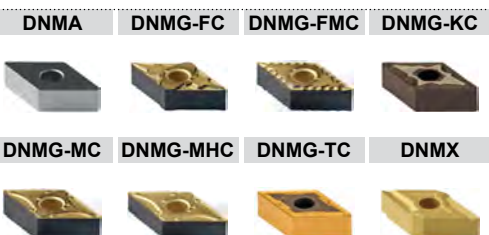



Characteristics:

Internal turning and profiling boring bar equipped with rhombic negative double-sided insert (angle 55°).

For low powered machines and small pieces choose boring bars Ref. A-SDUC (Page: A164).

Axial -6°
Radial -12°

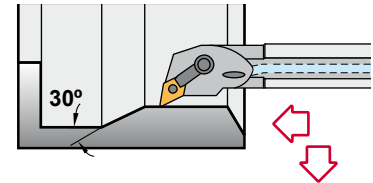
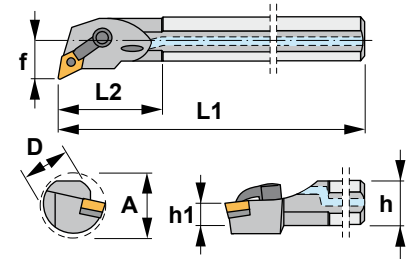

A-MDUN 93°

Reference	D	h	h1	L1	L2	f	A	Insert size	
A16T-MDUNR/L4	1.000	0.900	0.450	12.00	2.50	0.875	1.750	DN..43..	1.540
A20U-MDUNR/L4	1.250	1.180	0.590	14.00	3.00	1.000	2.000	DN..43..	4.510
A24U-MDUNR/L4	1.500	1.370	0.685	14.00	3.00	1.125	2.250	DN..43..	8.250
A32V-MDUNR/L4	2.000	1.870	0.935	16.00	4.00	1.375	3.000	DN..43..	13.750

Reference							Nm ¹	Nm ²
A16T-MDUNR/L4	CL-20	XNS-47	5103	-	NL-44	5124	3.0	3.5
A20U-MDUNR/L4	CL-20	XNS-48	5103	IDSN-432	NL-46	5124	3.0	3.5
A24U-MDUNR/L4	CL-20	XNS-48	5103	IDSN-432	NL-46	5124	3.0	3.5
A32V-MDUNR/L4	CL-20	XNS-48	5103	IDSN-432	NL-46	5124	3.0	3.5

DN..	55° rhombic negative inserts. A28-30		
Reference	l	T	d
DN..43..	0.610	0.187	0.500

**Characteristics:**

Boring bar for internal turning applications equipped with square negative inserts.
For low powered machines and small pieces choose boring bars Ref. SSKC (Page: A166).

Axial -3.25°
Radial -11°

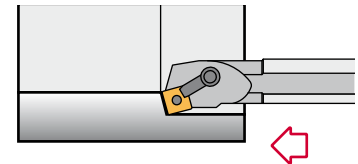
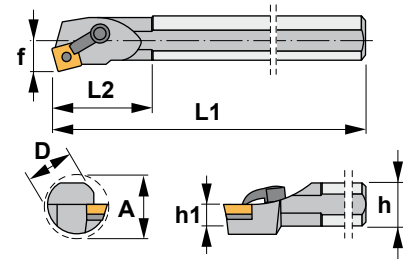

MSKN 75°

Reference	D	h	h1	L1	L2	f	A	Insert size	
S20U-MSKNR/L4	1.250	1.180	0.590	14.00	3.00	0.765	1.530	SNM..43..	4.510
S24U-MSKNR/L4	1.500	1.370	0.685	14.00	3.00	0.890	1.780	SNM..43..	8.250
S32V-MSKNR/L5	2.000	1.870	0.935	16.00	4.00	1.281	2.562	SNM..54..	13.750
S32V-MSKNR/L6	2.000	1.870	0.935	16.00	4.00	1.281	2.562	SNM..64..	13.750
S40V-MSKNR/L6	2.500	2.380	1.190	16.00	4.00	1.531	3.062	SNM..64..	21.800

Reference							Nm ¹	Nm ²
S20U-MSKNR/L4	CL-20	XNS-48	5103	ISSN-432	NL-46	5124	3.0	3.5
S24U-MSKNR/L4	CL-20	XNS-48	5103	ISSN-432	NL-46	5124	3.0	3.5
S32V-MSKNR/L5	CL-12	XNS-510	5004	ISSN-533	NL-58	5103	3.5	3.0
S32V-MSKNR/L6	CL-12	XNS-510	5004	ISSN-633	NL-68	5135	3.5	4.0
S40V-MSKNR/L6	CL-12	XNS-510	5004	ISSN-633	NL-68	5135	3.5	4.0

SNM..

Square negative inserts. A33-34

Reference	l	T	d
SNM..43..	0.500	0.187	0.500
SNM..54..	0.625	0.250	0.625
SNM..64..	0.750	0.250	0.750

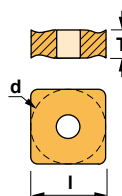

SNMG-FMC



SNMG-KC



SNMG-MHC



SNMG-RC



SNMG-TC



SNMM





Characteristics:

Internal turning and profiling boring bar equipped with triangular negative double-sided insert.

For low powered machines and small pieces choose boring bars Ref. STFC (Page: A167).

Axial -6°
Radial -11°

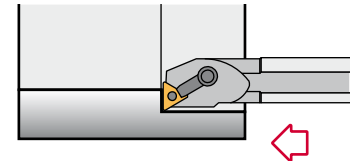
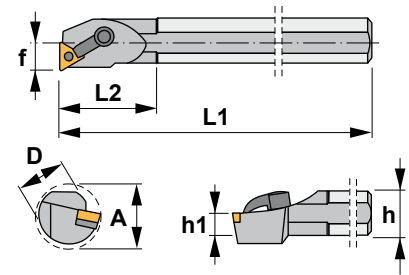

MTFN 90°

Reference	D	h	h1	L1	L2	f	A	Insert size	lbs
S16T-MTFNR/L3	1.000	0.900	0.450	12.00	2.50	0.640	1.280	TNM..33..	1.540
S20U-MTFNR/L3	1.250	1.180	0.590	14.00	3.00	0.765	1.530	TNM..33..	4.510
S24U-MTFNR/L3	1.500	1.370	0.685	14.00	3.00	0.890	1.780	TNM..33..	8.250
S20U-MTFNR/L4	1.250	1.180	0.590	14.00	3.00	0.765	1.530	TNM..43..	4.510
S24U-MTFNR/L4	1.500	1.370	0.685	14.00	3.00	0.890	1.780	TNM..43..	8.250
S28U-MTFNR/L4	1.750	1.630	0.815	14.00	4.00	1.015	2.030	TNM..43..	9.000
S32V-MTFNR/L4	2.000	1.870	0.935	16.00	4.00	1.281	2.562	TNM..43..	13.450
S40V-MTFNR/L4	2.500	2.380	1.190	16.00	4.00	1.531	3.062	TNM..43..	21.500
S32V-MTFNR/L5	2.000	1.870	0.935	16.00	4.00	1.281	2.562	TNM..54..	13.450

Reference							Nm ¹	Nm ²
S16T-MTFNR/L3	CL-20	XNS-47	5103	-	NL-33L	5102	3.0	1.4
S20U-MTFNR/L3	CL-20	XNS-48	5103	ITSN-322	NL-34L	5102	3.0	1.4
S24U-MTFNR/L3	CL-20	XNS-48	5103	ITSN-322	NL-34L	5102	3.0	1.4
S20U-MTFNR/L4	CL-20	XNS-48	5103	ITSN-433	NL-46	5124	3.0	3.5
S24U-MTFNR/L4	CL-20	XNS-48	5103	ITSN-433	NL-46	5124	3.0	3.5
S28U-MTFNR/L4	CL-20	XNS-48	5103	ITSN-433	NL-46	5124	3.0	3.5
S32V-MTFNR/L4	CL-20	XNS-48	5103	ITSN-433	NL-46	5124	3.0	3.5
S40V-MTFNR/L4	CL-20	XNS-48	5103	ITSN-433	NL-46	5124	3.0	3.5
S32V-MTFNR/L5	CL-12	XNS-510	5004	ITSN-533	NL-58	5103	3.5	3.0

TNM..

Triangular negative inserts. A37-38

Reference	l	T	d
TNM..33..	0.650	0.187	0.375
TNM..43..	0.866	0.187	0.500
TNM..54..	1.083	0.250	0.625

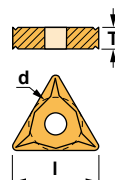



Characteristics:

Internal turning and profiling boring bar equipped with triangular negative double-sided insert.

For low powered machines and small pieces choose boring bars Ref. A-STFC (Page: A168).

Axial -6°
Radial -11°

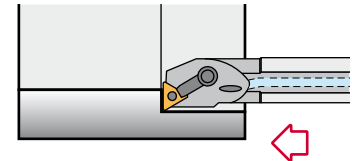
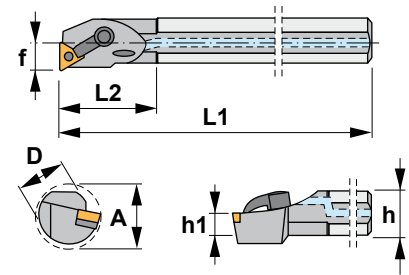

A-MTFN 90°

Reference	D	h	h1	L1	L2	f	A	Insert size	lbs
A16T-MTFNR/L3	1.000	0.900	0.450	12.00	2.50	0.640	1.280	TNM..33..	1.540
A20U-MTFNR/L3	1.250	1.180	0.590	14.00	3.00	0.765	1.530	TNM..33..	4.510
A24U-MTFNR/L4	1.500	1.370	0.685	14.00	3.00	0.890	1.780	TNM..43..	8.250
A28U-MTFNR/L4	1.750	1.630	0.815	14.00	4.00	1.015	2.030	TNM..43..	9.000
A32V-MTFNR/L4	2.000	1.870	0.935	16.00	4.00	1.281	2.562	TNM..43..	13.450

Reference							Nm ¹	Nm ²
A16T-MTFNR/L3	CL-20	XNS-47	5103	-	NL-33L	5102	3.0	1.4
A20U-MTFNR/L3	CL-20	XNS-48	5103	ITSN-322	NL-34L	5102	3.0	1.4
A24U-MTFNR/L4	CL-20	XNS-48	5103	ITSN-433	NL-46	5124	3.0	3.5
A28U-MTFNR/L4	CL-20	XNS-48	5103	ITSN-433	NL-46	5124	3.0	3.5
A32V-MTFNR/L4	CL-20	XNS-48	5103	ITSN-433	NL-46	5124	3.0	3.5

TNM..

Triangular negative inserts. A37-38

Reference	l	T	d
TNM..33..	0.650	0.187	0.375
TNM..43..	0.866	0.187	0.500

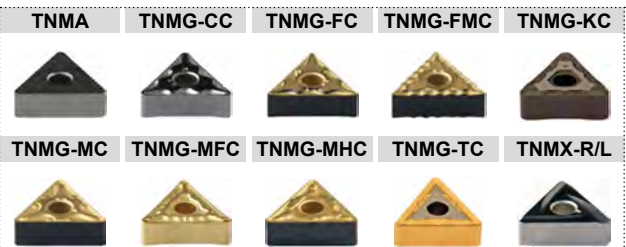
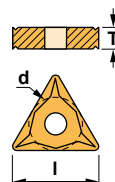



Characteristics:

Internal turning and profiling boring bar equipped with triangular negative double-sided insert.

For low powered machines and small pieces choose boring bars Ref. STFC (Page: A167).

Axial -6°
Radial -13°

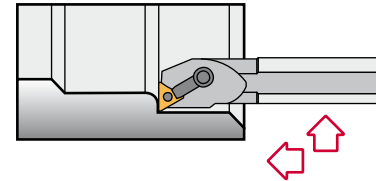
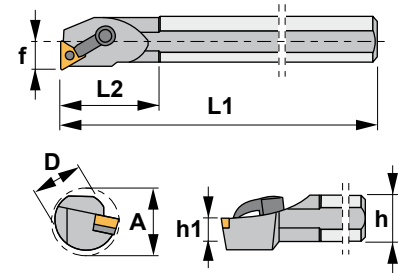

MTUN 93°

Reference	D	h	h1	L1	L2	f	A	Insert size	lbs
S16T-MTUNR/L3	1.000	0.900	0.450	12.00	2.50	0.640	1.280	TNM..33..	1.540
S20U-MTUNR/L3	1.250	1.180	0.590	14.00	3.00	0.765	1.530	TNM..33..	4.510
S24U-MTUNR/L4	1.500	1.370	0.685	14.00	3.00	0.890	1.780	TNM..43..	8.250

Reference							Nm ¹	Nm ²
S16T-MTUNR/L3	CL-20	XNS-47	5103	-	NL-33L	5102	3.0	1.4
S20U-MTUNR/L3	CL-20	XNS-48	5103	ITSN-322	NL-34L	5102	3.0	1.4
S24U-MTUNR/L4	CL-20	XNS-48	5103	ITSN-433	NL-46	5124	3.0	3.5

TNM..

Triangular negative inserts. A37-38

Reference	l	T	d
TNM..33..	0.650	0.187	0.375
TNM..43..	0.866	0.187	0.500

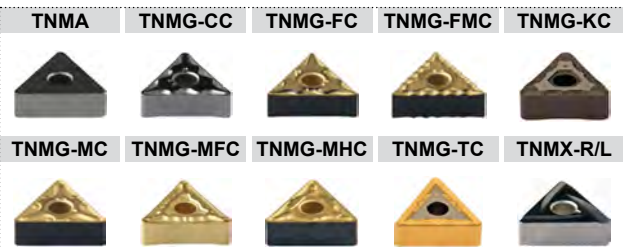
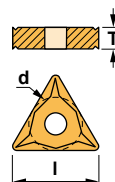



Characteristics:

Internal turning and profiling boring bar equipped with rhombic negative double-sided insert (angle 35°).





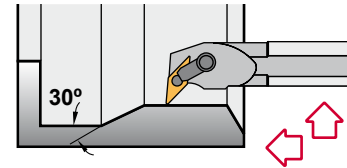
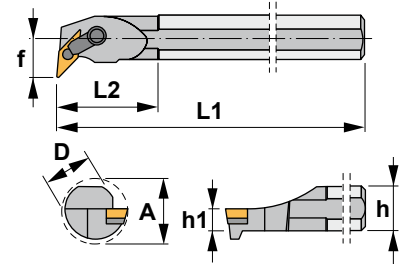

For low powered machines and small pieces choose boring bars Ref. SVUC (Page: A170).

Axial -5°
Radial -15°



MVUN 93°

Reference	D	h	h1	L1	L2	f	A	Insert size	
S16T-MVUNR/L3	1.000	0.900	0.450	12.00	2.50	1.000	2.000	VN..33..	1.540
S20U-MVUNR/L3	1.250	1.180	0.590	14.00	3.00	1.125	2.250	VN..33..	4.510
S24U-MVUNR/L3	1.500	1.370	0.685	14.00	3.00	1.250	2.500	VN..33..	8.250
S32V-MVUNR/L4	2.000	1.870	0.935	16.00	4.00	1.500	3.250	VN..43..	13.750
S40V-MVUNR/L4	2.500	2.380	1.190	16.00	4.00	1.750	3.750	VN..43..	21.800

Reference							Nm ¹	Nm ²
S16T-MVUNR/L3	CL-22	XNS-47	5103	IVSN-322	NL-34L	5102	3.0	1.4
S20U-MVUNR/L3	CL-22	XNS-48	5103	IVSN-322	NL-34L	5102	3.0	1.4
S24U-MVUNR/L3	CL-22	XNS-48	5103	IVSN-322	NL-34L	5102	3.0	1.4
S32V-MVUNR/L4	CL-12	XNS-510	5004	IVSN-432	NL-46	5124	3.5	3.5
S40V-MVUNR/L4	CL-12	XNS-510	5004	IVSN-432	NL-46	5124	3.5	3.5

VN..

35° rhombic negative inserts.  A41

Reference

Reference	l	T	d
VN..33..	0.650	0.187	0.375
VN..43..	0.866	0.187	0.500

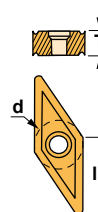

VNGP



VNMG



VNMG-TC





Characteristics:

Internal turning and profiling boring bar equipped with rhombic negative double-sided insert (angle 35°).

For low powered machines and small pieces choose boring bars Ref. SVUC (Page: A170).

Axial -5°
Radial -15°

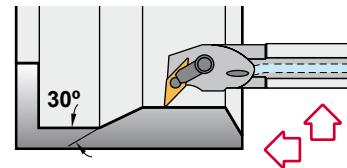
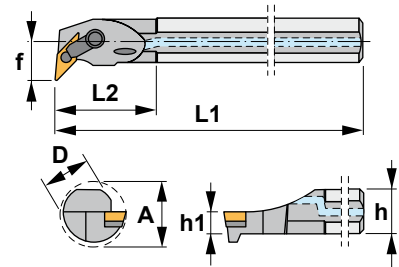

A-MVUN 93°

Reference	D	h	h1	L1	L2	f	A	Insert size	lbs
A16T-MVUNR/L3	1.000	0.900	0.450	12.00	2.50	1.000	2.000	VN..33..	1.540
A20U-MVUNR/L3	1.250	1.180	0.590	14.00	3.00	1.125	2.250	VN..33..	4.510
A24U-MVUNR/L3	1.500	1.370	0.685	14.00	3.00	1.250	2.500	VN..33..	8.250

Reference							Nm ¹	Nm ²
A16T-MVUNR/L3	CL-22	XNS-47	5103	IVSN-322	NL-34L	5102	3.0	1.4
A20U-MVUNR/L3	CL-22	XNS-48	5103	IVSN-322	NL-34L	5102	3.0	1.4
A24U-MVUNR/L3	CL-22	XNS-48	5103	IVSN-322	NL-34L	5102	3.0	1.4

VN..

35° rhombic negative inserts. A41

Reference

l T d

VN..33.. 0.650 0.187 0.375

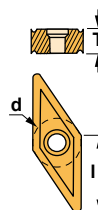

VNGP



VNMG



VNMG-TC



**Characteristics:**





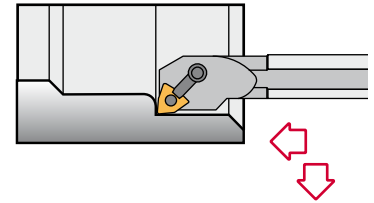
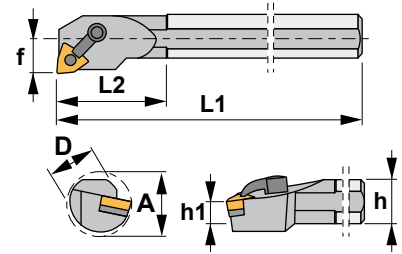

Multipurpose boring bar equipped with trigon negative double-sided insert (angle 80°). Internal profiling boring bar for general applications, roughing, semi-finishing and finishing.

Axial -6°
Radial -14°



MWLN 95°

Reference	D	h	h1	L1	L2	f	A	Insert size	
S16T-MWLN/R/L4	1.000	0.900	0.450	12.00	2.50	0.640	1.280	WNMG43..	1.540
S20U-MWLN/R/L4	1.250	1.180	0.590	14.00	3.00	0.765	1.530	WNMG43..	4.510
S24U-MWLN/R/L4	1.500	1.370	0.685	14.00	3.00	0.890	1.780	WNMG43..	8.250

Reference							Nm ¹	Nm ²
S16T-MWLN/R/L4	CL-20	XNS-47	5103	-	NL-44	5124	3.0	3.5
S20U-MWLN/R/L4	CL-20	XNS-48	5103	IWSN-433	NL-46	5124	3.0	3.5
S24U-MWLN/R/L4	CL-20	XNS-48	5103	IWSN-433	NL-46	5124	3.0	3.5

WNMG80° trigon negative inserts.  A42-43

Reference	l	T	d
WNMG43..	0.320	0.187	0.500

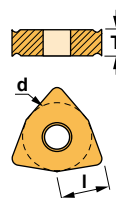

WNMG-FC	WNMG-FMC	WNMG-KC	WNMG-MFC
---------	----------	---------	----------



WNMG-MC	WNMG-MHC	WNMG-TC
---------	----------	---------





Characteristics:

Multipurpose boring bar equipped with trigon negative double-sided insert (angle 80°). Internal profiling boring bar for general applications, roughing, semi-finishing and finishing.

Axial -6°
Radial -14°

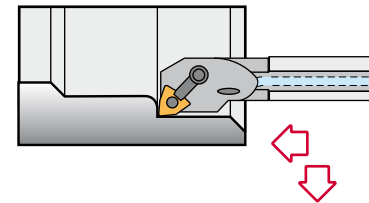
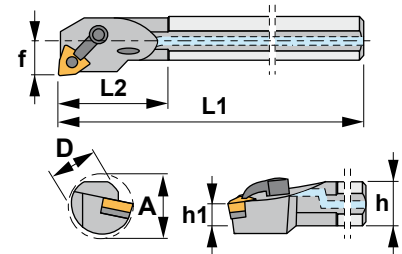

A-MWLN 95°

Reference	D	h	h1	L1	L2	f	A	Insert size	lbs
A12S-MWLN/L3	0.750	0.700	0.350	10.00	1.378	0.500	0.929	WNMG33..	0.850
A16T-MWLN/L4	1.000	0.900	0.450	12.00	2.500	0.640	1.280	WNMG43..	1.540
A20U-MWLN/L4	1.250	1.180	0.590	14.00	3.000	0.765	1.530	WNMG43..	4.510
A24U-MWLN/L4	1.500	1.370	0.685	14.00	3.000	0.890	1.780	WNMG43..	8.250

Reference								Nm ¹	Nm ²
A12S-MWLN/L3	CL-6	XNS-36	5102	-	NL-33L	5124	1.4	3.5	
A16T-MWLN/L4	CL-20	XNS-47	5103	-	NL-44	5124	3.0	3.5	
A20U-MWLN/L4	CL-20	XNS-48	5103	IWSN-433	NL-46	5124	3.0	3.5	
A24U-MWLN/L4	CL-20	XNS-48	5103	IWSN-433	NL-46	5124	3.0	3.5	

WNMG				80° trigon negative inserts. A42-43					
Reference	l	T	d						
WNMG33..	0.241	0.187	0.375			WNMG-FC	WNMG-FMC	WNMG-KC	WNMG-MFC
WNMG43..	0.320	0.187	0.500			WNMG-MC	WNMG-MHC	WNMG-TC	



Characteristics:

Internal turning and profiling boring bar equipped with triangular negative double-sided insert.

For low powered machines and small pieces choose boring bars Ref. CTFP (Page: A160) or STFC (page: A167).

Axial -6°
Radial -13°

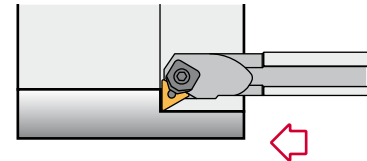
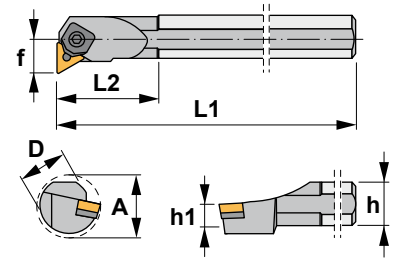

WTFN 90°

Reference	D	h	h1	L1	L2	f	A	Insert size	lbs
S16T-WTFNR/L3	1.000	0.900	0.450	12.00	2.50	0.640	1.280	TNM..33..	1.540
S20U-WTFNR/L3	1.250	1.180	0.590	14.00	3.00	0.765	1.530	TNM..33..	4.510
S24U-WTFNR/L3	1.500	1.370	0.685	14.00	3.00	0.890	1.780	TNM..33..	8.250
S20U-WTFNR/L4	1.250	1.180	0.590	14.00	3.00	0.765	1.530	TNM..43..	1.540
S24U-WTFNR/L4	1.500	1.370	0.685	14.00	3.00	0.890	1.780	TNM..43..	8.250
S28U-WTFNR/L4	1.750	1.630	0.815	14.00	4.00	1.015	2.030	TNM..43..	9.300
S32V-WTFNR/L4	2.000	1.870	0.935	16.00	4.00	1.281	2.562	TNM..43..	13.750
S40V-WTFNR/L4	2.500	2.380	1.180	16.00	4.00	1.531	3.062	TNM..43..	21.800

Reference						Nm
S16T-WTFNR/L3	2013	5105	3414	1644	1813	4.0
S20U-WTFNR/L3	2013	5105	3414	1644	1393	4.0
S24U-WTFNR/L3	2013	5105	3414	1644	1393	4.0
S20U-WTFNR/L4	2029	5105	ITSN-433	1661	1394	4.0
S24U-WTFNR/L4	2029	5105	ITSN-433	1661	1394	4.0
S28U-WTFNR/L4	2029	5105	ITSN-433	1661	1394	4.0
S32V-WTFNR/L4	2029	5105	ITSN-433	1661	1394	4.0
S40V-WTFNR/L4	2029	5105	ITSN-433	1661	1394	4.0

TNM..

Triangular negative inserts. A37-38

Reference	l	T	d
TNM..33..	0.650	0.187	0.375
TNM..43..	0.866	0.187	0.500

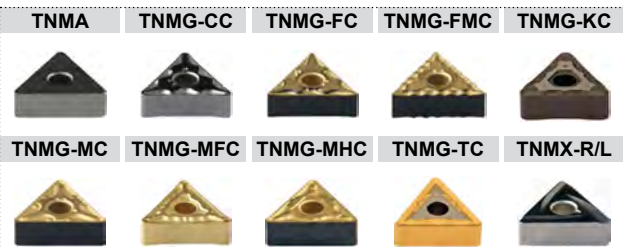
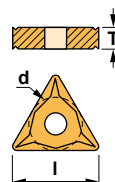



Characteristics:
 Internal turning and profiling boring bar equipped with triangular negative double-sided insert.
 Multipurpose boring bar for specific applications, roughing, semi-finishing and finishing.

Axial -6°
 Radial -13°

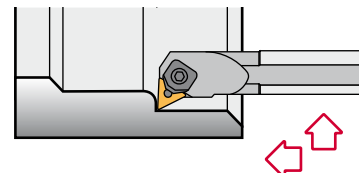
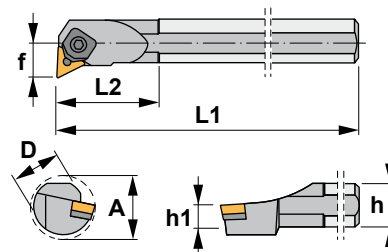

WTUN 93°

Reference	D	h	h1	L1	L2	f	A	Insert size	
S16T-WTUNR/L3	1.000	0.900	0.450	12.00	2.50	0.640	1.280	TNM..33..	1.540
S24U-WTUNR/L4	1.500	1.370	0.685	14.00	3.00	0.890	1.780	TNM..43..	8.250

Reference						Nm
S16T-WTUNR/L3	2013	5105	3414	1644	1813	4.0
S24U-WTUNR/L4	2029	5105	ITSN-433	1661	1394	4.0

TNM..

Triangular negative inserts. A37-38

Reference	l	T	d
TNM..33..	0.650	0.187	0.375
TNM..43..	0.866	0.187	0.500

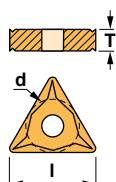



Characteristics:

Multipurpose boring bar equipped with trigon negative double-sided insert (angle 80°).

Not suitable for cermet, ceramic or K10, P10 grade inserts.

Axial -5°
Radial -14°

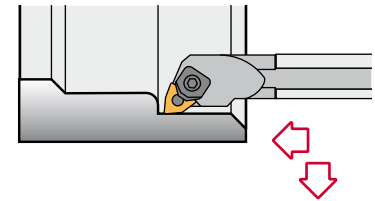
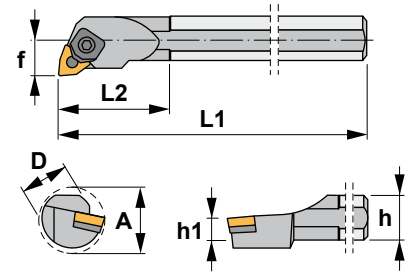

WWLN 95°

Reference	D	h	h1	L1	L2	f	A	Insert size	lbs
S12S-WWLNR/L3	0.750	0.710	0.355	10.00	1.50	0.500	1.000	WNMG33..	1.210
S16T-WWLNR/L4	1.000	0.900	0.450	12.00	2.50	0.640	1.280	WNMG43..	1.540
S20U-WWLNR/L4	1.250	1.180	0.590	14.00	3.00	0.765	1.530	WNMG43..	4.510
S24U-WWLNR/L4	1.500	1.370	0.685	14.00	3.00	0.890	1.780	WNMG43..	8.250

Reference						Nm
S12S-WWLNR/L3	2007	5126	-	1643	1813	4.0
S16T-WWLNR/L4	2012	5105	-	1647	1814	4.0
S20U-WWLNR/L4	2012	5105	IWSN-433	1661	1814	4.0
S24U-WWLNR/L4	2012	5105	IWSN-433	1661	1814	4.0

WNMG

80° trigon negative inserts. A42-43

Reference	l	T	d
WNMG33..	0.254	0.187	0.375
WNMG43..	0.320	0.187	0.500

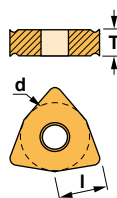

**Characteristics:**

Boring bar for internal turning applications equipped with square positive inserts.
For interrupted cut choose boring bars Ref. MSKN (Page: A148).

Axial 5.75°
Radial 1.5°

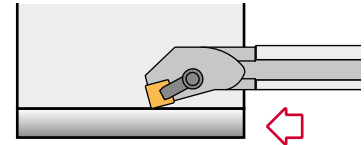
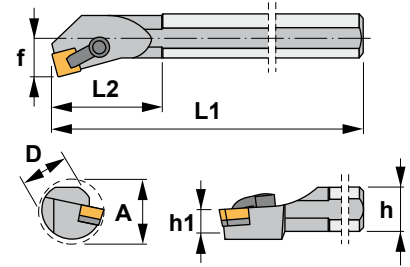

CSKP 75°

Reference	D	h	h1	L1	L2	f	A	Insert size	lbs
S16T-CSKPR/L4	1.000	0.900	0.450	12.00	2.50	0.640	1.180	SP..42..	2.310
S20U-CSKPR/L4	1.250	1.180	0.590	14.00	3.00	0.765	1.154	SP..42..	4.510
S24U-CSKPR/L4	1.500	1.370	0.685	14.00	3.00	0.890	1.800	SP..42..	8.030
S28U-CSKPR/L4	1.750	1.630	0.815	14.00	4.00	1.015	2.040	SP..42..	9.300
S24U-CSKPR/L6	1.500	1.370	0.685	14.00	3.00	0.890	2.060	SP..63..	8.030
S28U-CSKPR/L6	1.750	1.630	0.815	14.00	3.00	1.015	2.340	SP..63..	9.300
S32V-CSKPR/L6	2.000	1.870	0.935	16.00	4.00	1.281	2.580	SP..63..	13.750
S40V-CSKPR/L6	2.500	2.380	1.190	16.00	4.00	1.531	3.080	SP..63..	21.800

Reference						Nm
S16T-CSKPR/L4	CL-20	XNS-47	5103	-	-	3.0
S20U-CSKPR/L4	CL-20	XNS-47	5103	3112	4002	3.0
S24U-CSKPR/L4	CL-20	XNS-48	5103	3112	4002	3.0
S28U-CSKPR/L4	CL-20	XNS-48	5103	3112	4002	3.0
S24U-CSKPR/L6	CL-22	XNS-47	5004	3119	4012	3.5
S28U-CSKPR/L6	CL-22	XNS-48	5004	3119	4012	3.5
S32V-CSKPR/L6	CL-22	XNS-48	5004	3119	4012	3.5
S40V-CSKPR/L6	CL-22	XNS-48	5004	3119	4012	3.5

SP..

Square positive inserts with 11° clearance. A35

Reference

Reference	l	T	d
SP..42..	0.500	0.125	0.500
SP..63..	0.750	0.187	0.750

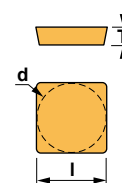
**SPMR****SPUN**



Characteristics:

Boring bar for internal turning applications equipped with triangular positive inserts. For interrupted cut choose boring bars Ref. MTFN (Page: A149).

Axial 6°
Radial 0°

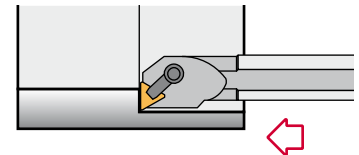
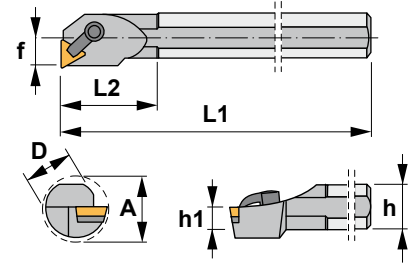

CTFP 90°

Reference	D	h	h1	L1	L2	f	A	Insert size	
S16T-CTFPR/L3	1.000	0.900	0.450	12.00	2.50	0.640	1.220	TP..32..	1.540
S20U-CTFPR/L3	1.250	1.180	0.590	14.00	3.00	0.765	1.600	TP..32..	4.510
S24U-CTFPR/L3	1.500	1.370	0.685	14.00	3.00	0.890	1.840	TP..32..	8.250
S28U-CTFPR/L3	1.750	1.630	0.815	14.00	4.00	1.015	2.100	TP..32..	9.300
S24U-CTFPR/L4	1.500	1.370	0.685	14.00	3.00	0.890	2.120	TP..43..	8.030
S28U-CTFPR/L4	1.750	1.630	0.815	14.00	3.00	1.015	2.380	TP..43..	9.300
S32V-CTFPR/L4	2.000	1.870	0.935	16.00	4.00	1.281	2.620	TP..43..	13.750
S40V-CTFPR/L4	2.500	2.380	1.190	16.00	4.00	1.531	3.120	TP..43..	21.800

Reference						Nm
S16T-CTFPR/L3	CL-7	XNS-34	5124	-	-	3.5
S20U-CTFPR/L3	CL-7	XNS-34	5124	3116	4002	3.5
S24U-CTFPR/L3	CL-6	XNS-36	5124	3116	4002	3.5
S28U-CTFPR/L3	CL-6	XNS-36	5124	3116	4002	3.5
S24U-CTFPR/L4	CL-20	XNS-47	5103	3122	4012	3.0
S28U-CTFPR/L4	CL-20	XNS-48	5103	3122	4012	3.0
S32V-CTFPR/L4	CL-20	XNS-48	5103	3122	4012	3.0
S40V-CTFPR/L4	CL-20	XNS-48	5103	3122	4012	3.0

TP..

Triangular positive inserts with 11° clearance.  A39

Reference	l	T	d
TP..32..	0.650	0.125	0.375
TP..43..	0.866	0.187	0.500

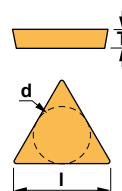

TPMN



TPUX-R



TPMR



TPUX-L



TPUN





Characteristics:

Multipurpose boring bar equipped with rhombic positive insert (angle 80°).
For boring bars with negative inserts see Ref. MCLN (Page: A144).

Axial 0°
Radial -9°

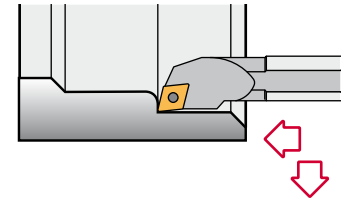
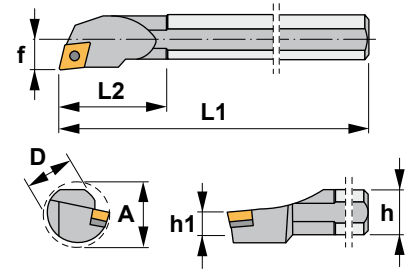

SCLC 95°

Reference	D	h	h1	L1	L2	f	A	Insert size	
S06M-SCLCR/L2	0.375	0.340	0.170	6.00	0.830	0.250	0.500	CC..21.5..	0.132
S08M-SCLCR/L2	0.500	0.460	0.230	6.00	0.910	0.312	0.625	CC..21.5..	0.330
S10R-SCLCR/L2	0.625	0.580	0.290	8.00	1.060	0.406	0.812	CC..21.5..	0.660
S08M-SCLCR/L3	0.500	0.460	0.230	6.00	0.984	0.312	0.625	CC..32.5..	0.330
S10R-SCLCR/L3	0.625	0.580	0.290	8.00	1.060	0.406	0.812	CC..32.5..	0.660
S12S-SCLCR/L3M	0.750	0.710	0.355	10.00	1.580	0.500	1.000	CC..32.5..	1.210
S16T-SCLCR/L3M	1.000	0.900	0.450	12.00	1.810	0.640	1.280	CC..32.5..	1.210
S16T-SCLCR/L4	1.000	0.900	0.450	12.00	3.000	0.640	1.280	CC..43..	1.540
S20U-SCLCR/L4	1.250	1.180	0.590	14.00	3.000	0.765	1.530	CC..43..	4.510
S24V-SCLCR/L4	1.500	1.370	0.685	15.75	3.000	0.890	1.780	CC..43..	8.250

Reference					Nm
S06M-SCLCR/L2	1425	5507	-	-	0.9
S08M-SCLCR/L2	1425	5507	-	-	0.9
S10R-SCLCR/L2	1425	5507	-	-	0.9
S08M-SCLCR/L3	1440	5515	-	-	3.0
S10R-SCLCR/L3	1440	5515	-	-	3.0
S12S-SCLCR/L3M	1440	5515	-	-	3.0
S16T-SCLCR/L3M	1440	5515	-	-	3.0
S16T-SCLCR/L4	1250	5520	-	-	4.0
S20U-SCLCR/L4	1540	5517	3614	1760	
S24V-SCLCR/L4	1540	5517	3614	1760	

CC..

80° rhombic positive inserts with 7° clearance. A23

Reference	l	T	d
CC..21.5..	0.254	0.093	0.250
CC..32.5..	0.380	0.156	0.375
CC..43..	0.508	0.187	0.500

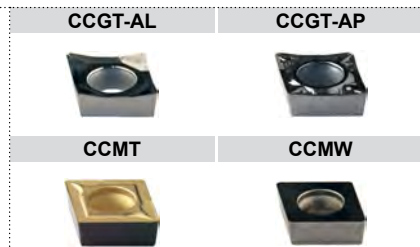
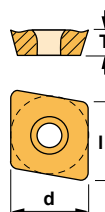





Characteristics:

Multipurpose boring bar equipped with rhombic positive insert (angle 80°).
For boring bars with negative inserts see Ref. MCLN (Page: A144).

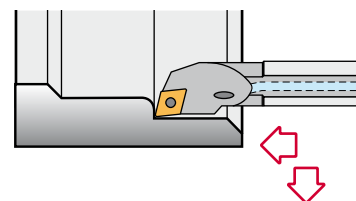
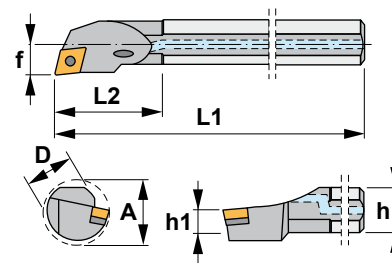
Axial 0°
Radial -9°



A-SCLC 95°

Reference	D	h	h1	L1	L2	f	A	Insert size	
A06M-SCLCR/L2	0.375	0.340	0.170	6.00	0.830	0.250	0.500	CC..21.5..	0.132
A08M-SCLCR/L2	0.500	0.460	0.230	6.00	0.910	0.312	0.625	CC..21.5..	0.330
A10R-SCLCR/L2	0.625	0.580	0.290	8.00	1.060	0.406	0.812	CC..21.5..	0.660
A10R-SCLCR/L3	0.625	0.580	0.290	8.00	1.060	0.406	0.812	CC..32.5..	0.660
A12S-SCLCR/L3M	0.750	0.710	0.355	10.00	1.580	0.500	1.000	CC..32.5..	1.210

Reference			Nm
A06M-SCLCR/L2	1425	5507	0.9
A08M-SCLCR/L2	1425	5507	0.9
A10R-SCLCR/L2	1425	5507	0.9
A10R-SCLCR/L3	1440	5515	3.0
A12S-SCLCR/L3M	1440	5515	3.0

CC..

80° rhombic positive inserts with 7° clearance.  A23

Reference

Reference	l	T	d
CC..21.5..	0.254	0.093	0.250
CC..32.5..	0.380	0.156	0.375

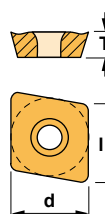

CCGT-AL



CCGT-AP



CCMT



CCMW





Characteristics:
 Multipurpose profiling boring bar equipped with rhombic positive insert (angle 55°).
 For boring bars with negative inserts see Ref. MDUN (Page: A146).

Axial 0°
 Radial -8°

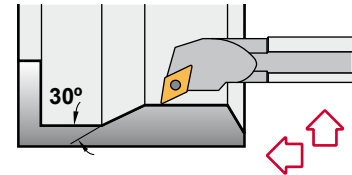
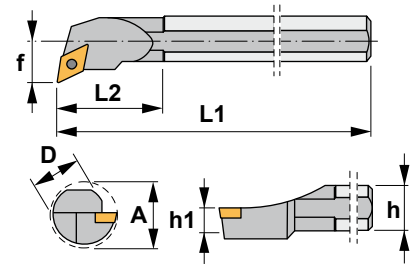

SDUC 93°

Reference	D	h	h1	L1	L2	f	A	Insert size	lbs
S06M-SDUCR/L2	0.375	0.340	0.170	6.00	0.830	0.375	0.750	DC..21.5..	0.132
S08M-SDUCR/L2	0.500	0.460	0.230	6.00	0.910	0.438	0.875	DC..21.5..	0.330
S10R-SDUCR/L2	0.625	0.580	0.290	8.00	1.060	0.500	1.000	DC..21.5..	0.660
S12S-SDUCR/L3M	0.750	0.710	0.355	10.00	1.580	0.625	1.250	DC..32.5..	1.210
S16T-SDUCR/L3M	1.000	0.900	0.450	12.00	1.810	0.750	1.500	DC..32.5..	1.540
S20U-SDUCR/L3M	1.250	1.180	0.590	14.00	1.890	0.875	1.750	DC..32.5..	4.510

Reference					Nm
S06M-SDUCR/L2	1425	5507	-	-	0.9
S08M-SDUCR/L2	1225	5507	-	-	0.9
S10R-SDUCR/L2	1225	5507	-	-	0.9
S12S-SDUCR/L3M	1240	5515	-	-	3.0
S16T-SDUCR/L3M	1240	5515	-	-	3.0
S20U-SDUCR/L3M	1335	5516	3714	1750	3.0

DC..

55° rhombic positive inserts with 7° clearance. A27

Reference	l	T	d
DC..21.5..	0.305	0.093	0.250
DC..32.5..	0.456	0.156	0.375

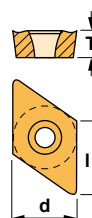

DCGT-AL



DCGT-AP



DCMT



DCMW





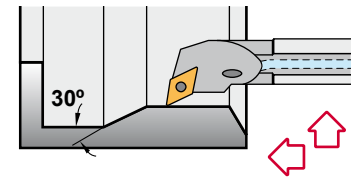
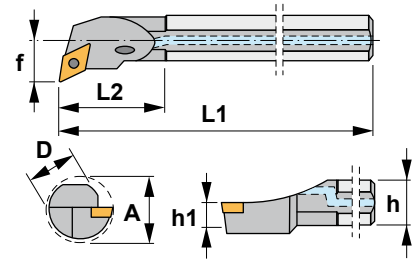

Characteristics:
 Multipurpose profiling boring bar equipped with rhombic positive insert (angle 55°).
 For boring bars with negative inserts see Ref. A-MDUN (Page: A147).

Axial 0°
 Radial -8°



A-SDUC 93°

Reference	D	h	h1	L1	L2	f	A	Insert size	
A06M-SDUCR/L2	0.375	0.340	0.170	6.00	0.830	0.375	0.750	DC..21.5..	0.132
A08M-SDUCR/L2	0.500	0.460	0.230	6.00	0.910	0.438	0.875	DC..21.5..	0.330
A10R-SDUCR/L2	0.625	0.580	0.290	8.00	1.060	0.500	1.000	DC..21.5..	0.660
A12S-SDUCR/L3M	0.750	0.710	0.355	10.00	1.580	0.625	1.250	DC..32.5..	1.210

Reference			Nm
A06M-SDUCR/L2	1425	5507	0.9
A08M-SDUCR/L2	1225	5507	0.9
A10R-SDUCR/L2	1225	5507	0.9
A12S-SDUCR/L3M	1240	5515	3.0

DC..

55° rhombic positive inserts with 7° clearance.  A27

Reference	l	T	d
DC..21.5..	0.305	0.093	0.250
DC..32.5..	0.456	0.156	0.375

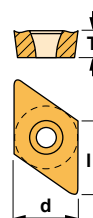

DCGT-AL



DCGT-AP



DCMT



DCMW





Characteristics:

Backwards multipurpose profiling boring bar equipped with rhombic positive insert (angle 55°).

Profiling and copying boring bar for semi-finishing and finishing operations.

Axial 0°
Radial -6°

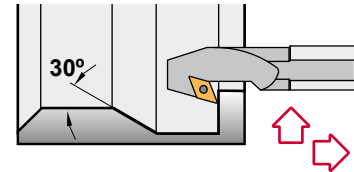
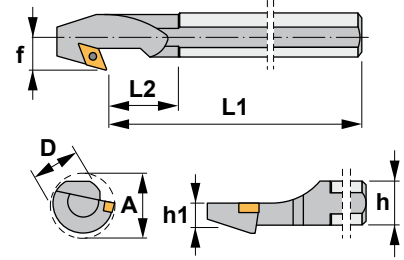

SDUC 93°-EX

Reference	D	h	h1	L1	L2	f	A	Insert size	
S12S-SDUCR/L2EX	0.750	0.710	0.355	10.00	0.760	0.625	1.250	DC..21.5..	1.210
S16T-SDUCR/L2DX	1.000	0.900	0.450	12.00	1.000	0.750	1.500	DC..21.5..	1.540
S20U-SDUCR/L3X	1.250	1.180	0.590	14.00	1.270	0.765	1.750	DC..32.5..	4.510

Reference					Nm
S12S-SDUCR/L2EX	1225	5507	-	-	0.9
S16T-SDUCR/L2DX	1225	5507	-	-	0.9
S20U-SDUCR/L3X	1335	5516	3714	1750	3.0

DC..

55° rhombic positive inserts with 7° clearance. A27

Reference	l	T	d
DC..21.5..	0.305	0.093	0.250
DC..32.5..	0.456	0.156	0.375

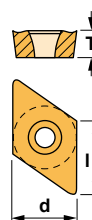

DCGT-AL



DCGT-AP



DCMT



DCMW





Characteristics:

Multipurpose boring bar equipped with square positive insert.
For boring bars with negative inserts see Ref. MSKN (Page: A148).

Axial 0°
Radial -7°

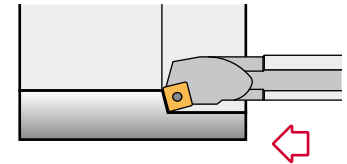
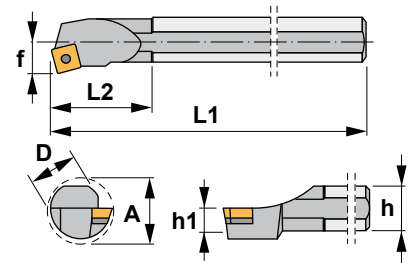

SSKC 75°

Reference	D	h	h1	L1	L2	f	A	Insert size	
S10R-SSKCR/L3	0.625	0.580	0.290	8.00	1.060	0.406	0.812	SC..32.5..	0.660
S12S-SSKCR/L3	0.750	0.710	0.355	10.00	1.580	0.500	1.000	SC..32.5..	1.210
S16T-SSKCR/L3	1.000	0.900	0.450	12.00	1.810	0.640	1.280	SC..32.5..	1.540

Reference			Nm
S10R-SSKCR/L3	1440	5515	3.0
S12S-SSKCR/L3	1240	5515	3.0
S16T-SSKCR/L3	1240	5515	3.0

SC..

Square positive inserts with 7° clearance.  A32

Reference

l

T

d

SC..32.5..

0.375

0.156

0.375

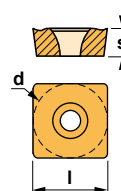

SCGT-AL



SCMT



SCMT-39



SCMW





Characteristics:
 Multipurpose boring bar equipped with triangular positive insert.
 For boring bars with negative inserts see Ref. MTFN (Page: A149).

Axial 0°
 Radial -12°

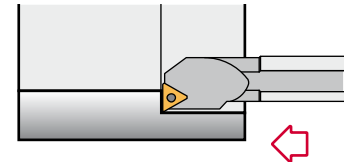
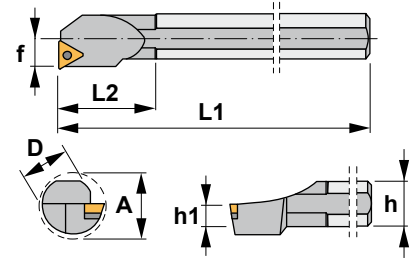

STFC 90°

Reference	D	h	h1	L1	L2	f	A	Insert size	lbs
S06M-STFCR/L2	0.375	0.340	0.170	6.00	0.850	0.250	0.500	TC..21.5..	0.132
S08M-STFCR/L2	0.500	0.460	0.230	6.00	0.800	0.312	0.625	TC..21.5..	0.330
S10R-STFCR/L2	0.625	0.580	0.290	8.00	0.960	0.406	0.812	TC..21.5..	0.660
S12S-STFCR/L2	0.750	0.710	0.355	10.00	1.420	0.500	1.000	TC..21.5..	1.210
S16T-STFCR/L3	1.000	0.900	0.450	12.00	1.930	0.640	1.280	TC..32.5..	1.540
S20U-STFCR/L3	1.250	1.180	0.590	14.00	1.970	0.765	1.530	TC..32.5..	4.510
S24V-STFCR/L3	1.500	1.370	0.685	15.75	2.360	0.890	1.780	TC..32.5..	8.250

Reference					Nm
S06M-STFCR/L2	1425	5507	-	-	0.9
S08M-STFCR/L2	1425	5507	-	-	0.9
S10R-STFCR/L2	1225	5507	-	-	0.9
S12S-STFCR/L2	1225	5507	-	-	0.9
S16T-STFCR/L3	1240	5515	-	-	3.0
S20U-STFCR/L3	1335	5516	3414	1750	3.0
S24V-STFCR/L3	1335	5516	3414	1750	3.0

TC..

Triangular positive inserts with 7° clearance. A36

Reference	l	T	d
TC..21.5..	0.433	0.094	0.250
TC..32.5..	0.650	0.156	0.375

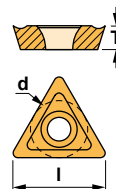

TCGT-AL

TCMT



TCMW







Characteristics:

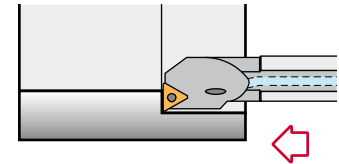
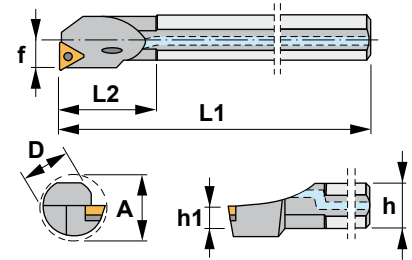

Multipurpose boring bar equipped with triangular positive insert.
For boring bars with negative inserts see Ref. MTFN (Page: A149).

Axial 0°
Radial -12°



A-STFC 90°

Reference	D	h	h1	L1	L2	f	A	Insert size	
A06M-STFCR/L2	0.375	0.340	0.170	6.00	0.850	0.250	0.500	TC..21.5..	0.132
A08M-STFCR/L2	0.500	0.460	0.230	6.00	0.800	0.312	0.625	TC..21.5..	0.330
A10R-STFCR/L2	0.625	0.580	0.290	8.00	0.960	0.406	0.812	TC..21.5..	0.660
A12S-STFCR/L2	0.750	0.710	0.355	10.00	1.420	0.500	1.000	TC..21.5..	1.210

Reference			Nm
A06M-STFCR/L2	1425	5507	0.9
A08M-STFCR/L2	1225	5507	0.9
A10R-STFCR/L2	1225	5507	0.9
A12S-STFCR/L2	1225	5507	0.9

TC..

Triangular positive inserts with 7° clearance.  A36

Reference

l

T

d

TC..21.5..

0.433

0.094

0.250

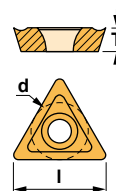

TCGT-AL



TCMT



TCMW





Characteristics:
 Multipurpose profiling boring bar equipped with rhombic positive insert (angle 35°).
 For general applications, roughing, semi-finishing and finishing.

Axial 0°
 Radial -6°

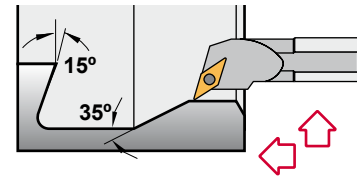
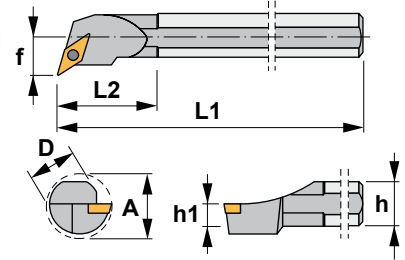

SVQC 107°30'

Reference	D	h	h1	L1	L2	f	A	Insert size	
S16T-SVQCR/L3	1.000	0.900	0.450	12.00	0.910	0.750	1.375	VC..33..	1.540
S20U-SVQCR/L3	1.250	1.180	0.590	14.00	1.060	0.875	1.625	VC..33..	4.510
S24V-SVQCR/L3	1.500	1.370	0.685	15.75	1.370	1.063	2.000	VC..33..	8.250

Reference					Nm
S16T-SVQCR/L3	1240	5515	-	-	3.0
S20U-SVQCR/L3	1335	5516	3718	1750	3.0
S24V-SVQCR/L3	1335	5516	3718	1750	3.0

VC..				35° rhombic positive inserts with 7° clearance. A40	
Reference	l	T	d		
VC..33..	0.650	0.187	0.375		



Characteristics:

Multipurpose profiling boring bar equipped with rhombic positive insert (angle 35°).
For boring bars with negative inserts see Ref. MVUN (Page: A152).

Axial 0°
Radial -7°

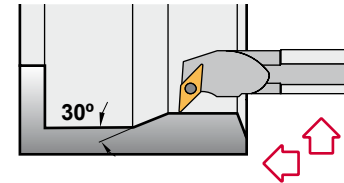
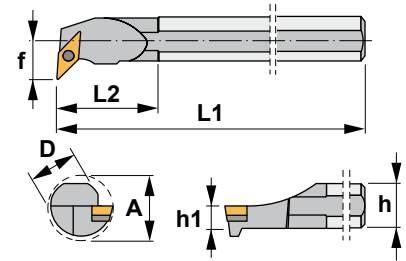

SVUC 93°

Reference	D	h	h1	L1	L2	f	A	Insert size	lbs
S10R-SVUCR/L2E	0.625	0.580	0.290	8.00	1.060	0.500	0.867	VC..22..	0.660
S12S-SVUCR/L2E	0.750	0.710	0.355	10.00	1.580	0.625	1.060	VC..22..	1.210
S16T-SVUCR/L2D	1.000	0.900	0.450	12.00	1.810	0.750	1.300	VC..22..	1.540
S20U-SVUCR/L3	1.250	1.180	0.590	14.00	3.000	1.000	2.000	VC..33..	4.510
S24V-SVUCR/L3	1.500	1.370	0.685	15.75	3.000	1.125	2.250	VC..33..	8.250
S32W-SVUCR/L3	2.000	1.870	0.935	17.75	4.000	1.375	2.750	VC..33..	15.210

Reference					Nm
S10R-SVUCR/L2E	1225	5507	-	-	0.9
S12S-SVUCR/L2E	1225	5507	-	-	0.9
S16T-SVUCR/L2D	1225	5507	-	-	0.9
S20U-SVUCR/L3	1335	5516	3718	1750	3.0
S24V-SVUCR/L3	1335	5516	3718	1750	3.0
S32W-SVUCR/L3	1335	5516	3718	1750	3.0

VC..

35° rhombic positive inserts with 7° clearance. A40

Reference

Reference	l	T	d
VC..22..	0.433	0.125	0.250
VC..33..	0.650	0.187	0.375

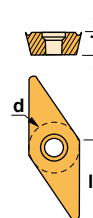

VCGT-AL



VCGT-AP



VCMT



J..

Anti-vibration shank



Strong tightening

With the use of “split” sleeves the clamping force (black colour) will be as high as possible and the bar will work optimally.

Machining recommendations

Notes for anti-vibration shank

Centering line

The anti-vibration bar is centered by taking as a reference the plane indicated by the arrow.



Calibration procedure

The bars are supplied pre-calibrated, but a new, different calibration may be necessary, depending on the type of application.

The variables to consider are many:

- Head type
- Insert type
- Material to be machined
- Cutting depth
- Speeds and feeds, etc.

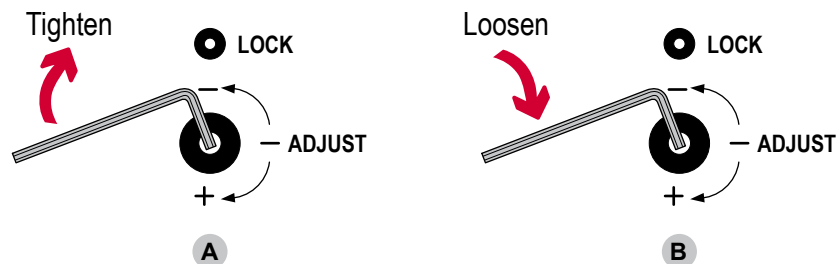

Machining recommendations

Notes for anti-vibration shank

Calibration procedure



- 1 - Make sure that the LOCKING screw is loose.
- 2 - Calibrate by turning the ADJUSTING screw by tightening or loosening.
- A - If the frequency of the vibration produces a high sound, tighten the adjustment.
- B - If the frequency of the vibration produces a low sound, loosen the adjustment
- 3 - Make sure that the LOCKING screw is tightened.
- 4 - Try the tool and, if necessary, repeat the adjustments until you obtain satisfactory results.

Use a suitable SLEEVE in order to have a vibration-free tool.

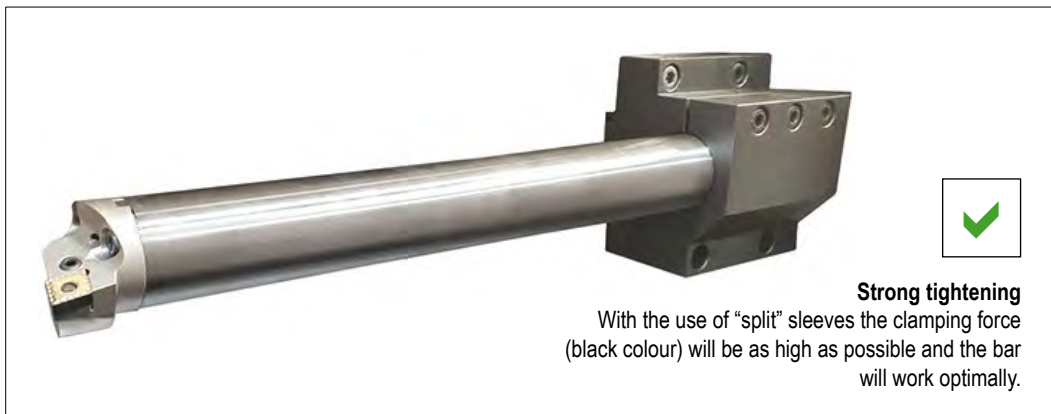
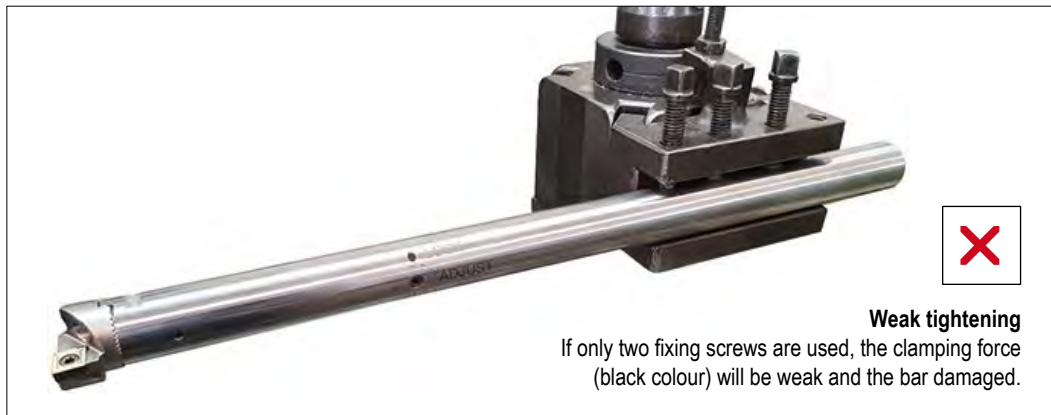

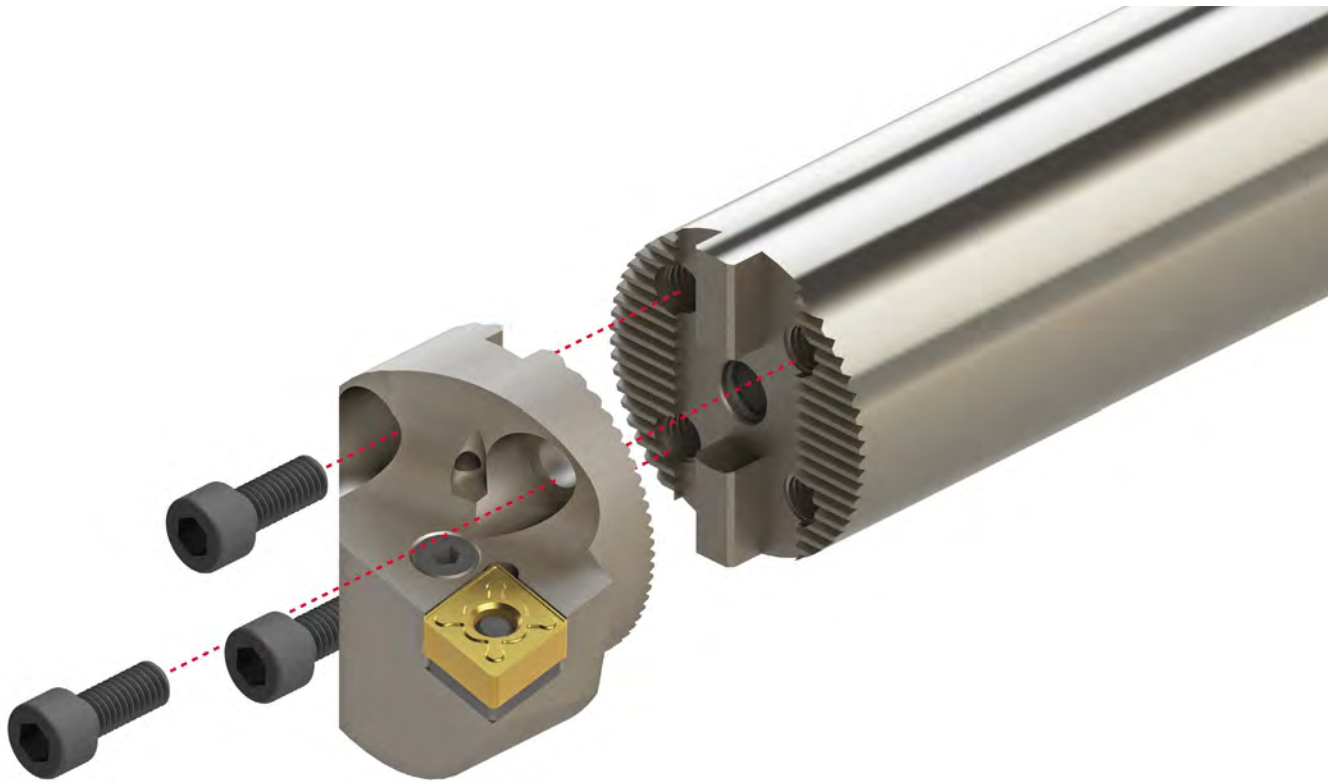



MTUN 93°-N	PCLN 95°-N	PDUN 93°-N	PWLN 95°-N
SCLC 95°-N	SDUC 93°-N	STFC 90°-N	STXN 90°-N



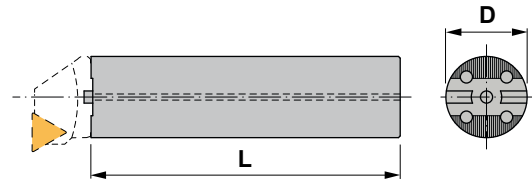

Characteristics:
 Anti-vibration shank with internal coolant.
 Max. cutting depth: 7 x Diameter



J..  

Reference		D	L	Thread	 lbs
J16/1200	25	1.000	12.00	1/4-18 NPT	2.645
J20/1400	32	1.250	14.00	1/4-18 NPT	4.850
J24/1600	32	1.500	16.00	1/4-18 NPT	5.900
J28/1800	40	1.750	18.00	1/4-18 NPT	8.820
J32/2000	50	2.000	20.00	1/4-18 NPT	18.740
J40/2500	60	2.500	25.00	1/4-18 NPT	31.750

Reference			Nm
J16/1200	1924	5025	2.0
J20/1400	1925	5003	3.0
J24/1600	1925	5003	3.0
J28/1800	1926	5004	3.5
J32/2000	1928	5005	4.0
J40/2500	1928	5005	4.0



Characteristics:
 Internal turning and profiling boring head equipped with triangular negative double-sided insert.
 For general applications, roughing, semi-finishing and finishing.

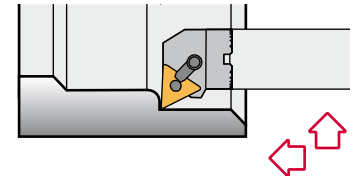
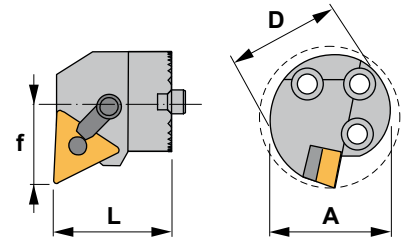

MTUN 93°-N

Reference	D	L	f	A	Insert size	lbs
A32X-MTUNR/L16-N	1.260	1.811	0.866	1.575	TNM..33..	0.330
A40X-MTUNR/L16-N	1.575	1.811	1.063	1.968	TNM..33..	0.660
A50X-MTUNR/L16-N	1.968	1.811	1.378	2.480	TNM..33..	1.435
A50X-MTUNR/L22-N	1.968	1.575	1.378	2.480	TNM..43..	1.435
A60X-MTUNR/L22-N	2.362	1.575	1.693	3.150	TNM..43..	1.875

Reference								Nm ¹	Nm ²	
A32X-MTUNR/L16-N	2613	-	5003	ITSN-322	1086	1665	-	5002	3.0	1.4
A40X-MTUNR/L16-N	2613	-	5003	ITSN-322	1086	1665	-	5002	3.0	1.4
A50X-MTUNR/L16-N	2613	-	5003	ITSN-322	1086	1665	-	5002	3.0	1.4
A50X-MTUNR/L22-N	-	2024	5005	ITSN-433	1394	-	1661	-	4.0	-
A60X-MTUNR/L22-N	-	2024	5005	ITSN-433	1394	-	1661	-	4.0	-

TNM.. Triangular negative inserts. A37-38

Reference	l	T	d
TNM..33..	0.650	0.187	0.375
TNM..43..	0.866	0.187	0.500

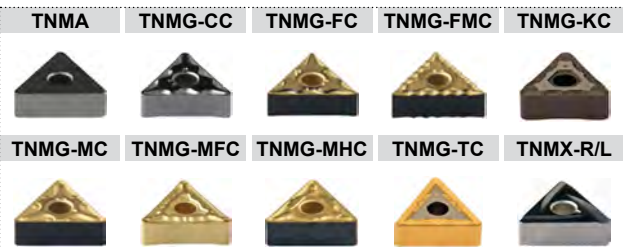
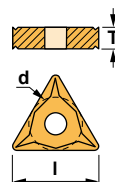



Characteristics:

Boring head for internal turning applications equipped with rhombic negative inserts (angle 80°). For low powered machines and small pieces choose boring bars Ref. A-SCLC (Page: A162).

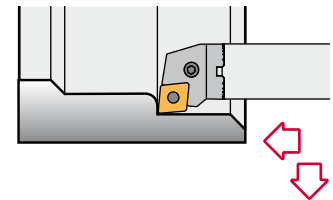
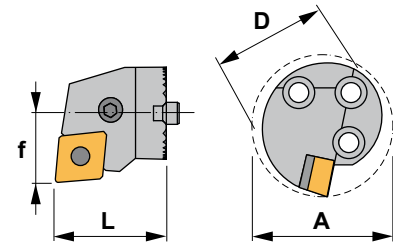

PCLN 95°-N

Reference	D	L	f	A	Insert size	lbs
A25X-PCLNR/L12-N	0.984	1.811	0.669	1.260	CN..43..	0.110
A32X-PCLNR/L12-N	1.260	1.811	0.866	1.575	CN..43..	0.330
A40X-PCLNR/L12-N	1.575	1.811	1.063	1.968	CN..43..	0.660
A50X-PCLNR/L12-N	1.968	1.811	1.378	2.480	CN..43..	1.325
A60X-PCLNR/L12-N	2.362	1.575	1.693	3.150	CN..43..	1.765
A50X-PCLNR/L16-N	1.968	1.575	1.378	2.480	CN..54..	1.325
A60X-PCLNR/L16-N	2.362	1.575	1.693	3.150	CN..54..	1.765

Reference							Nm
A25X-PCLNR/L12-N	8212	1626	5025	-	-	-	2.0
A32X-PCLNR/L12-N	8312	1648	5003	3612	4112	0012	3.0
A40X-PCLNR/L12-N	8012	1608	5003	3612	4112	0012	3.0
A50X-PCLNR/L12-N	8012	1608	5003	3612	4112	0012	3.0
A60X-PCLNR/L12-N	8012	1608	5003	3612	4112	0012	3.0
A50X-PCLNR/L16-N	8016	1618	5003	3616	4115	0015	3.0
A60X-PCLNR/L16-N	8016	1618	5003	3616	4115	0015	3.0

CN..

80° rhombic negative inserts. A24-26

Reference	l	T	d
CN..43..	0.508	0.187	0.500
CN..54..	0.630	0.250	0.625

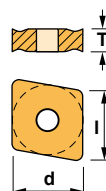



Characteristics:

Boring head for internal turning and profiling applications equipped with rhombic negative inserts (angle 55°). For low powered machines and small pieces choose boring bars Ref. A-SDUC (Page: A164).

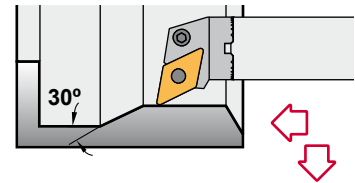
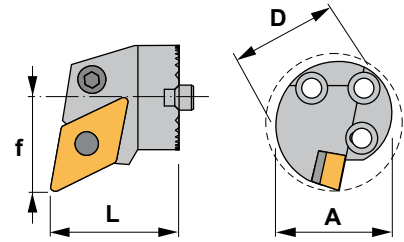

PDUN 93°-N

Reference	D	L	f	A	Insert size	
A32X-PDUNR/L15-N	1.260	1.378	0.866	1.575	DN..44..	0.330
A40X-PDUNR/L15-N	1.575	1.811	1.063	1.968	DN..44..	0.660
A50X-PDUNR/L15-N	1.968	1.575	1.378	2.480	DN..44..	1.325
A60X-PDUNR/L15-N	2.362	1.575	1.693	3.150	DN..44..	1.765

Reference									Nm
A32X-PDUNR/L15-N	8415	1648	5003	3715	4112	0012	3725	4135	3.0
A40X-PDUNR/L15-N	8415	1638	5003	3715	4112	0012	3725	4135	3.0
A50X-PDUNR/L15-N	8415	1638	5003	3715	4112	0012	3725	4135	3.0
A60X-PDUNR/L15-N	8415	1638	5003	3715	4112	0012	3725	4135	3.0

For DNM..43.. inserts

DN..

55° rhombic negative inserts. A28-30

Reference	l	T	d
DN..43..	0.610	0.187	0.500
DN..44..	0.610	0.250	0.500

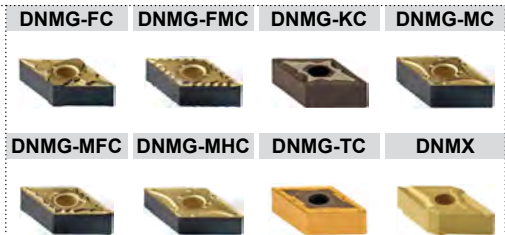



Characteristics:

Boring head for internal turning applications equipped with trigon negative inserts (angle 80°). For general applications, roughing, semi-finishing and finishing.

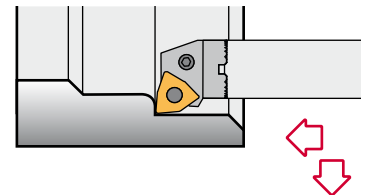
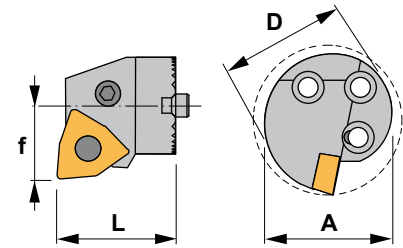

PWLN 95°-N

Reference	D	L	f	A	Insert size	lbs
A32X-PWLN/L08-N	1.260	1.811	0.866	1.575	WNMG43..	0.330
A40X-PWLN/L08-N	1.575	1.811	1.063	1.968	WNMG43..	0.660
A50X-PWLN/L08-N	1.968	1.575	1.378	2.480	WNMG43..	1.325
A60X-PWLN/L08-N	2.362	1.575	1.693	3.150	WNMG43..	1.765

Reference							Nm
A32X-PWLN/L08-N	8012	1608	5003	3008	4112	0012	3.0
A40X-PWLN/L08-N	8012	1608	5003	3008	4112	0012	3.0
A50X-PWLN/L08-N	8012	1608	5003	3008	4112	0012	3.0
A60X-PWLN/L08-N	8012	1608	5003	3008	4112	0012	3.0

WNMG

80° trigon negative inserts. A42-43

Reference	l	T	d
WNMG43..	0.320	0.187	0.500

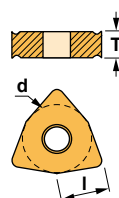



Characteristics:
 Multipurpose boring head equipped with rhombic positive insert (angle 80°).

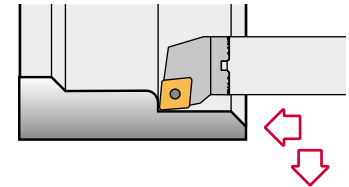
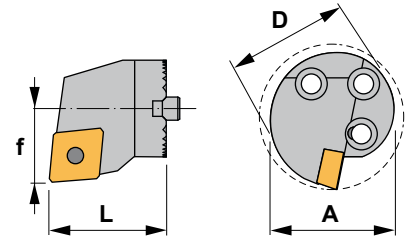

SCLC 95°-N

Reference	D	L	f	A	Insert size	
A25X-SCLCR/L09-N	0.984	0.984	0.669	1.260	CC..32.5..	0.155
A32X-SCLCR/L12-N	1.260	1.811	0.866	1.575	CC..43..	0.330
A40X-SCLCR/L12-N	1.575	1.811	1.063	1.968	CC..43..	0.550
A50X-SCLCR/L12-N	1.968	1.575	1.378	2.480	CC..43..	1.435
A60X-SCLCR/L12-N	2.362	1.575	1.693	3.150	CC..43..	1.875

Reference					Nm
A25X-SCLCR/L09-N	1440	5515	-	-	3.0
A32X-SCLCR/L12-N	1540	5517	3614	1760	3.0
A40X-SCLCR/L12-N	1540	5517	3614	1760	3.0
A50X-SCLCR/L12-N	1540	5517	3614	1760	3.0
A60X-SCLCR/L12-N	1540	5517	3614	1760	3.0

CC..

80° rhombic positive inserts with 7° clearance. A23

Reference	l	T	d
CC..32.5..	0.380	0.156	0.375
CC..43..	0.508	0.187	0.500

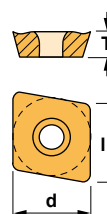

CCGT-AL



CCGT-AP



CCMT



CCMW





Characteristics:
Multipurpose profiling boring head equipped with rhombic positive insert (angle 55°).

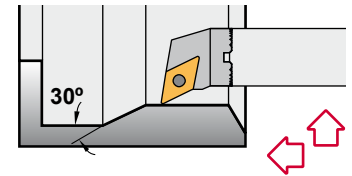
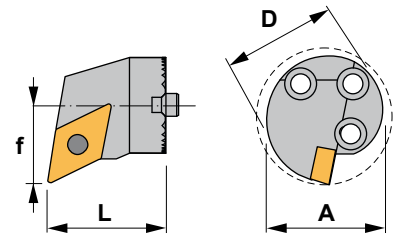

SDUC 93°-N

Reference	D	L	f	A	Insert size	
A25X-SDUCR/L11-N	0.984	0.984	0.669	1.260	DC..32.5..	0.155
A32X-SDUCR/L11-N	1.260	1.811	0.866	1.575	DC..32.5..	0.330
A40X-SDUCR/L11-N	1.575	1.811	1.063	1.968	DC..32.5..	0.550
A50X-SDUCR/L11-N	1.968	1.575	1.378	2.480	DC..32.5..	1.435
A60X-SDUCR/L11-N	2.362	1.575	1.693	3.150	DC..32.5..	1.875

Reference					Nm
A25X-SDUCR/L11-N	1240	5515	-	-	3.0
A32X-SDUCR/L11-N	1335	5516	3714	1750	3.0
A40X-SDUCR/L11-N	1335	5516	3714	1750	3.0
A50X-SDUCR/L11-N	1335	5516	3714	1750	3.0
A60X-SDUCR/L11-N	1335	5516	3714	1750	3.0

DC.. 55° rhombic positive inserts with 7° clearance. A27

Reference	l	T	d
DC..32.5..	0.457	0.156	0.375

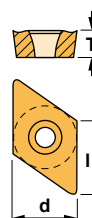

DCGT-AL



DCGT-AP



DCMT



DCMW





Characteristics:
 Multipurpose boring head equipped with triangular positive insert.
 For general applications, roughing, semi-finishing and finishing.

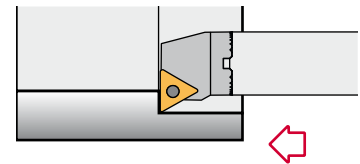
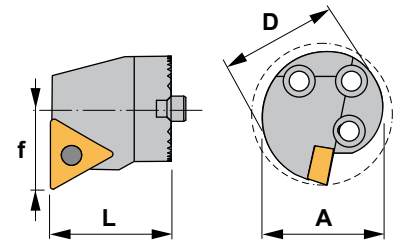

STFC 90°-N

Reference	D	L	f	A	Insert size	
A25X-STFCR/L16-N	0.984	0.984	0.669	1.260	TC..32.5..	0.155
A32X-STFCR/L16-N	1.260	1.811	0.866	1.575	TC..32.5..	0.330
A40X-STFCR/L16-N	1.575	1.811	1.063	1.968	TC..32.5..	0.550
A50X-STFCR/L16-N	1.968	1.575	1.378	2.480	TC..32.5..	1.435
A60X-STFCR/L16-N	2.362	1.575	1.693	3.150	TC..32.5..	1.875

Reference					Nm
A25X-STFCR/L16-N	1240	5515	-	-	3.0
A32X-STFCR/L16-N	1335	5516	3414	1750	3.0
A40X-STFCR/L16-N	1335	5516	3414	1750	3.0
A50X-STFCR/L16-N	1335	5516	3414	1750	3.0
A60X-STFCR/L16-N	1335	5516	3414	1750	3.0

TC..	Triangular positive inserts with 7° clearance. A36				TCGT-AL	TCMT
	Reference	l	T		d	
	TC..32.5..	0.650	0.156	0.375	TCMW	



Characteristics:
Boring head for internal threading
equipped with triangular negative
insert.

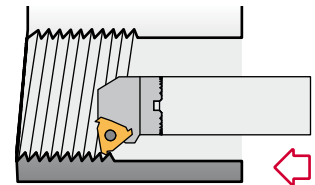
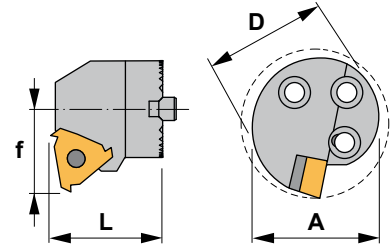

STXN 90°-N

Reference	D	L	f	A	Insert size	lbs
A25X-STXNR/L16-N	0.984	0.984	0.641	1.260	16NR/L..	0.155
A32X-STXNR/L16-N	1.260	1.811	0.771	1.575	16NR/L..	0.330
A32X-STXNR/L22-N	1.260	1.260	0.846	1.575	22NR/L..	0.330
A40X-STXNR/L22-N	1.575	1.260	1.015	1.968	22NR/L..	0.550
A50X-STXNR/L22-N	1.968	1.575	1.236	2.480	22NR/L..	1.435
A60X-STXNR/L22-N	2.362	1.575	1.433	3.150	22NR/L..	1.875

Reference							Nm
A25X-STXNR/L16-N	SA3	SA3	YE3	YE3	SY3	SY3	2.0
A32X-STXNR/L16-N	SA3	SA3	YE3	YE3	SY3	SY3	2.0
A32X-STXNR/L22-N	SA4	SA4	YE4	YE4	SY4	SY4	4.0
A40X-STXNR/L22-N	SA4	SA4	YE4	YE4	SY4	SY4	4.0
A50X-STXNR/L22-N	SA4	SA4	YE4	YE4	SY4	SY4	4.0
A60X-STXNR/L22-N	SA4	SA4	YE4	YE4	SY4	SY4	4.0

NR/L

Triangular negative inserts for internal threading. C04, C06-07, C09-10

Reference	l	d
16NR/L..	0.629	0.375
22NR/L..	0.866	0.500

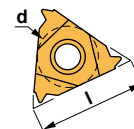

N R/L



N R/L TD



Nominal cutting speed and feed values for boring bars

Material	P	Type of treatment	Alloy	Hardness HB
Non alloyed steel		Annealed Annealed Tempered	≤ .15% C .15% - .45% C ≥ .45% C	125 150-250 300
Low alloyed steel		Annealed Tempered Tempered		180 250-300 350
High alloyed steel		Annealed Tempered		200 350
Corrosion-resistant steel		Annealed Tempered	ferritic martensitic	200 325
Material	M	Type of treatment	Alloy	Hardness HB
Stainless steel		Annealed Quenched Quenched Hardened	ferritic / martensitic austenitic duplex martensitic / austenitic	200 180 230-260 330
Material	K	Type of treatment	Alloy	Hardness HB
Gray cast iron			pearlitic / ferritic pearlitic / martensitic	180 260
Spheroidal cast iron			ferritic pearlitic	160 -
Malleable cast iron			ferritic pearlitic	130 230
Material	N	Type of treatment	Alloy	Hardness HB
Aluminium wrought alloys		Non hardened Hardened		60 100
Aluminium cast alloys		Non hardened Hardened Non hardened	< 12% Si < 12% Si < 12% Si	80 90 130
Copper and copper alloys (bronze, brass)			machining alloy stock (1% Pb) brass, red bronze bronze lead-free copper and electrolytic copper	- 90 100 100
Non-metallic materials			thermosetting plastics fiber-reinforced plastics hard rubber	- - -
Material	S	Type of treatment	Alloy	Hardness HB
Heat-resistant alloys		Annealed Hardened Annealed Hardened Cast	Fe-base Fe-base Ni or Co-base Ni or Co-base 30 - 58 HRC Ni or Co-base 1500 - 2200 N/mm ²	200 280 250 - -
Titanium alloys			pure titanium alpha + beta alloys	R _m 440* R _m 1050*
Material	H	Type of treatment	Alloy	Hardness HB
Tempered steel		Hardened and tempered Hardened and tempered		55 HRC 60 HRC
Chilled castings		Cast		400
Tempered cast iron		Hardened and tempered		55 HRC

* R_m = ultimate tensile strength, measured in MPa



Uncoated carbide		Coated carbide						Cermet
KM15	ZR10	TK15	TN15	TN30	TN35	TS15	TS20	NC25
V _c (sfpm)	V _c (sfpm)	V _c (sfpm)	V _c (sfpm)	V _c (sfpm)	V _c (sfpm)	V _c (sfpm)	V _c (sfpm)	V _c (sfpm)
-	-	754-1476	853-1640	585-748	-	-	-	1312-1706
-	-	656-1115	722-1312	553-618	-	-	-	1148-1312
-	-	525-886	590-984	423-488	-	-	-	984-1148
-	-	656-1181	853-1312	553-618	-	-	-	1312-1440
-	-	492-951	656-1050	293-488	-	-	-	984-1180
-	-	426-853	492-918	228-423	-	-	-	820-984
-	-	492-951	590-1050	390-650	-	-	-	1017-1245
-	-	328-853	394-918	163-325	-	-	-	917-1312
-	-	525-951	656-1050	455-585	-	-	-	1148-1312
-	-	426-820	492-918	358-520	-	-	-	851-1017
Uncoated carbide		Coated carbide						Cermet
KM15	ZR10	TK15	TN15	TN30	TN35	TS15	TS20	NC25
V _c (sfpm)	V _c (sfpm)	V _c (sfpm)	V _c (sfpm)	V _c (sfpm)	V _c (sfpm)	V _c (sfpm)	V _c (sfpm)	V _c (sfpm)
-	-	-	722-984	455-650	140-200	492-656	423-715	820-1050
-	-	-	-	358-618	110-190	394-656	390-585	984-1148
-	-	-	-	260-488	80-150	294-525	163-293	-
-	-	-	-	179-244	55-75	197-263	-	689-820
Uncoated carbide		Coated carbide						Cermet
KM15	ZR10	TK15	TN15	TN30	TN35	TS15	TS20	NC25
V _c (sfpm)	V _c (sfpm)	V _c (sfpm)	V _c (sfpm)	V _c (sfpm)	V _c (sfpm)	V _c (sfpm)	V _c (sfpm)	V _c (sfpm)
394-525	455-656	492-1312	459-1214	-	-	394-525	-	1114-1573
294-458	328-525	590-1148	459-1082	-	-	294-425	-	853-1180
425-558	522-656	656-1476	623-1410	-	-	394-525	-	1181-1706
294-425	361-492	525-984	459-886	-	-	394-589	-	984-1312
458-656	525-722	656-1804	590-1706	-	-	458-722	-	1081-1640
394-525	458-589	525-1148	492-1082	-	-	361-525	-	589-1050
Uncoated carbide		Coated carbide						Cermet
KM15	ZR10	TK15	TN15	TN30	TN35	TS15	TS20	NC25
V _c (sfpm)	V _c (sfpm)	V _c (sfpm)	V _c (sfpm)	V _c (sfpm)	V _c (sfpm)	V _c (sfpm)	V _c (sfpm)	V _c (sfpm)
984-11480	984-9840	-	-	-	-	328-1968	-	-
656-6560	656-8200	-	-	-	-	328-1312	-	-
1312-4920	1312-6560	-	-	-	-	328-1968	-	-
1312-4920	1312-5904	-	-	-	-	328-1312	-	-
656-2624	656-3280	-	-	-	-	328-1312	-	-
820-1968	820-2624	-	-	-	-	328-1968	-	-
656-1968	656-2624	-	-	-	-	328-1968	-	-
492-1312	492-1968	-	-	-	-	328-1312	-	-
492-984	492-1312	-	-	-	-	328-1312	-	-
261-589	328-7216	-	-	-	-	-	-	-
197-492	263-656	-	-	-	-	-	-	-
328-820	328-656	-	-	-	-	-	-	-
Uncoated carbide		Coated carbide						Cermet
KM15	ZR10	TK15	TN15	TN30	TN35	TS15	TS20	NC25
V _c (sfpm)	V _c (sfpm)	V _c (sfpm)	V _c (sfpm)	V _c (sfpm)	V _c (sfpm)	V _c (sfpm)	V _c (sfpm)	V _c (sfpm)
-	115-164	-	-	-	-	66-164	260-390	-
-	82-130	-	-	-	-	66-164	195-325	-
-	82-130	-	-	-	-	48-130	114-293	-
-	66-97	-	-	-	-	66-115	98-163	-
-	48-82	-	-	-	-	33-82	98-146	-
-	261-458	-	-	-	-	261-455	228-390	-
-	130-328	-	-	-	-	82-145	130-228	-
Uncoated carbide		Coated carbide						Cermet
KM15	ZR10	TK15	TN15	TN30	TN35	TS15	TS20	NC25
V _c (sfpm)	V _c (sfpm)	V _c (sfpm)	V _c (sfpm)	V _c (sfpm)	V _c (sfpm)	V _c (sfpm)	V _c (sfpm)	V _c (sfpm)
-	-	-	-	-	-	-	-	-
-	-	-	-	-	-	-	-	-
-	-	-	-	-	-	-	-	-
-	-	-	-	-	-	-	-	-

Lever lock
Double lock
Top clamp
Center screw

