

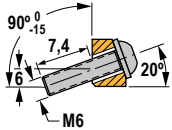
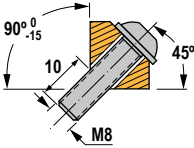
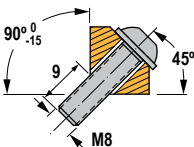
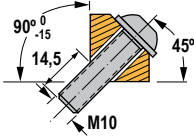

CARTRIDGES CARTUTXOS

Technical information Informació tècnica	A250-251
Code system (ISO) Codificació (ISO)	A252
Applications index Índex d'aplicacions	A253
Lever lock cartridges Cartutxos amb fixació per palanca	A254-258
Top clamp cartridges Cartutxos amb fixació per brida superior	A259-262
Center screw cartridges Cartutxos amb fixació per cargol central	A263-267

Assembly dimensions
Mides de muntatge

Cartridge size Mida del cartutx	Cartridge code Referència cartutx	Dimensions / Mides, mm											
		K _r	b _c	h ₁	h ₂₁	l ₈	l ₂₁	l ₂₂	l ₂₃	D _{m1} min	D _{m2} min	R max	ch max
12CA 	PSKN R/L 12CA-12	75°	14,0	12	16,0	35,0	36,5	56,5	52,0	50	-	5,0	0,4
	PSSN R/L 12CA-12	45°	14,0	12	16,0	27,0	32,0	52,0	40,5	50	-	5,0	0,4
	PTFN R/L 12CA-16	90°	14,0	12	16,0	35,0	33,0	53,0	49,0	50	-	5,0	0,4
	PTGN R/L 12CA-16	90°	14,0	12	16,0	35,0	30,5	50,5	45,0	50	75	5,0	0,4
	PTSN R/L 12CA-16	45°	14,0	12	16,0	27,0	33,5	53,5	49,0	50	-	5,0	0,4
	PTTN R/L 12CA-16	60°	14,0	12	16,0	35,0	30,5	50,5	49,0	50	75	5,0	0,4
	PTWN R/L 12CA-16	60°	14,0	12	16,0	27,0	30,5	50,5	46,0	50	-	5,0	0,4
16CA 	PCFN R/L 16CA-12	90°	17,5	16	20,5	38,0	34,0	59,0	55,0	55	-	6,0	0,4
	PCLN R/L 16CA-12	95°	17,5	16	20,5	38,0	32,0	57,0	54,0	55	75	6,0	0,4
	PSKN R/L 16CA-12	75°	17,5	16	20,5	38,0	38,5	63,5	55,0	55	-	6,0	0,4
	PSRN R/L 16CA-12	75°	19,0	16	20,5	38,0	27,5	52,5	51,0	60	75	6,0	0,4
	PSSN R/L 16CA-12	45°	17,0	16	20,5	28,0	31,5	56,5	41,0	55	75	6,0	0,4
	PTFN R/L 16CA-16	90°	17,5	16	21,5	38,0	35,0	60,0	54,0	55	-	6,0	0,4
	PTGN R/L 16CA-16	90°	18,5	16	20,5	38,0	32,0	57,0	55,0	60	75	6,0	0,4
	PTSN R/L 16CA-16	45°	17,0	16	20,5	28,0	32,5	57,5	54,0	55	-	6,0	0,4
	PTTN R/L 16CA-16	60°	15,3	16	20,5	25,0	36,0	61,0	54,0	55	75	6,0	0,4
PTWN R/L 16CA-16	60°	19,5	16	21,0	28,0	36,0	61,0	54,0	55	75	6,0	0,4	
20CA 	PCFN R/L 20CA-12	90°	16,0	20	26,0	40,0	-	-	61,0	-	-	6,0	0,4
	PCLN R/L 20CA-12	95°	15,6	20	25,0	40,0	-	-	61,0	-	-	6,0	0,4
	PSKN R/L 20CA-12	75°	16,5	20	26,0	40,0	41,0	71,0	64,0	-	-	6,0	0,4
	PSRN R/L 20CA-12	75°	21,5	20	25,0	40,0	33,0	63,0	68,0	-	90	6,0	0,4
	PSSN R/L 20CA-12	45°	18,2	20	27,0	30,0	35,0	65,0	60,0	70	-	6,0	0,4
	PTFN R/L 20CA-22	90°	15,5	20	27,0	40,0	37,0	67,0	61,0	70	-	6,0	0,4
	PTGN R/L 20CA-22	90°	16,0	20	25,0	40,0	32,5	62,5	56,7	70	90	6,0	0,4
	PTSN R/L 20CA-22	45°	15,5	20	25,0	30,0	37,0	67,0	62,0	70	-	6,0	0,4
	PTTN R/L 20CA-22	60°	18,1	20	26,0	22,5	-	-	61,5	-	-	6,0	0,4
PTWN R/L 20CA-22	60°	17,4	20	26,0	29,6	-	-	61,0	-	-	6,0	0,4	
25CA 	PCFN R/L 25CA-16	90°	24,0	25	32,9	50,0	-	-	88,5	-	-	8,0	0,7
	PCLN R/L 25CA-16	95°	24,6	25	32,9	50,0	41,5	91,5	90,6	100	115	8,0	0,7
	PSKN R/L 25CA-15	75°	24,0	25	31,9	49,0	-	-	93,5	-	-	8,0	0,7
	PTFN R/L 25CA-22	90°	21,5	25	32,9	50,0	-	-	88,5	-	-	8,0	0,7
	PTSN R/L 25CA-22	45°	23,7	25	32,9	39,0	-	-	72,8	-	-	8,0	0,7

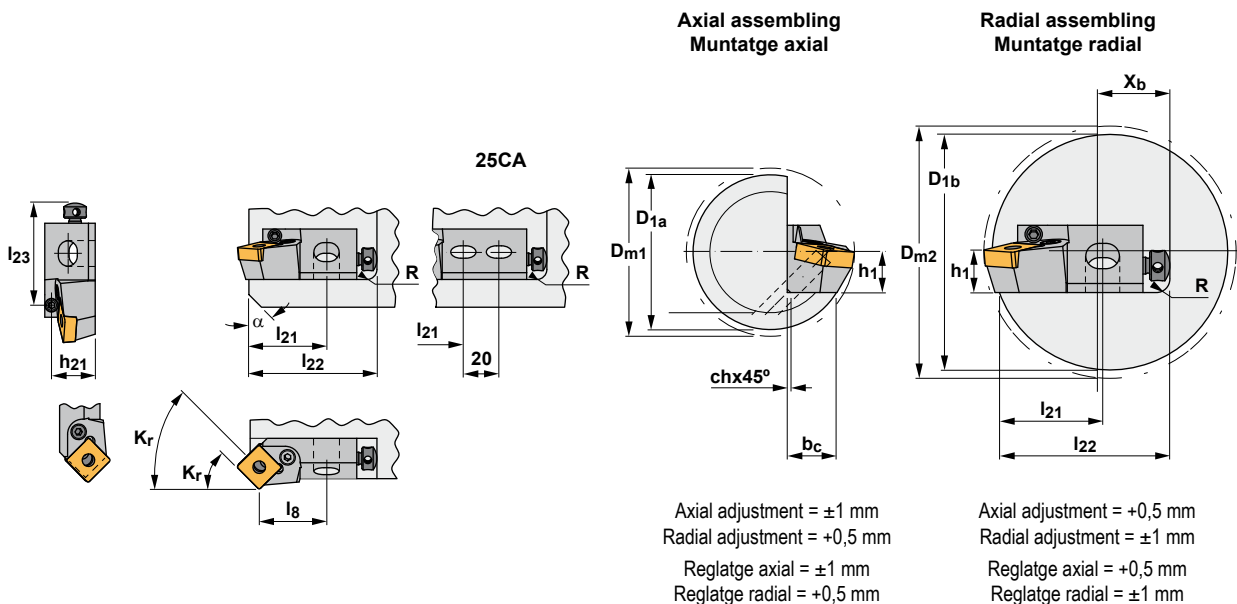

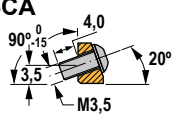
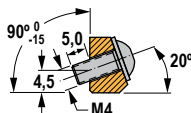
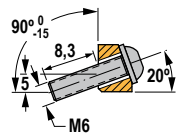
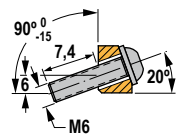
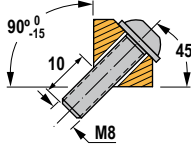

Assembly dimensions
Mides de muntatge

Cartridge size Mida del cartutx	Cartridge code Referència cartutx	Dimensions / Mides, mm											
		K _r	b _c	h ₁	h ₂₁	l ₈	l ₂₁	l ₂₂	l ₂₃	D _{m1} min	D _{m2} min	R max	ch max
06CA 	SCFC R/L 06CA-06	90°	7,2	6	2,1	13	12,0	24,0	18,0	20	31	2,5	0,3
	SCLC R/L 06CA-06	95°	7,8	6	2,1	13	12,0	24,0	18,0	20	31	2,5	0,3
08CA 	SCFC R/L 08CA-06	90°	6,0	8	2,2	15	13,5	30,5	24,2	25	38	1,5	0,3
	SCLC R/L 08CA-06	95°	5,8	8	2,9	15	13,5	30,5	24,2	25	38	2,5	0,3
	STFC R/L 08CA-09	90°	6,5	8	2,2	15	13,5	30,5	24,2	25	38	2,5	0,3
	STFC R/L 08CA-11	90°	6,8	8	2,9	15	13,5	30,5	24,2	25	38	2,5	0,3
	STSC R/L 08CA-09	45°	6,0	8	2,5	11	13,5	30,5	21,5	25	38	2,5	0,3
	STSC R/L 08CA-11	45°	5,8	8	2,9	10	13,5	30,5	21,5	25	38	2,5	0,3
	STTC R/L 08CA-09	60°	6,0	8	2,5	15	12,2	29,2	21,5	25	37	2,5	0,3
	STTC R/L 08CA-11	60°	6,6	8	2,9	9,6	13,5	30,5	22,4	25	38	2,5	0,3
	STWC R/L 08CA-11	60°	5,8	8	2,9	9,8	13,5	30,5	23,9	25	38	2,5	0,3
10CA 	SCFC R/L 10CA-09	90°	9,0	10	3,0	30	27,5	47,5	39,5	40	55	2,5	0,3
	SCLC R/L 10CA-09	95°	10,0	10	3,0	30	28,5	48,5	39,0	40	55	4,0	0,4
	SSKC R/L 10CA-09	75°	9,8	10	3,0	30	28,5	48,5	39,0	40	55	4,0	0,4
	SSSC R/L 10CA-09	45°	10,0	10	3,0	30	28,5	48,5	37,5	40	55	4,0	0,4
	STFC R/L 10CA-11	90°	10,6	10	3,0	30	27,5	47,5	39,5	40	55	4,0	0,4
	STGC R/L 10CA-11	90°	9,0	10	3,0	30	26,5	46,5	39,5	40	55	4,0	0,4
	STSC R/L 10CA-11	45°	9,0	10	3,0	24	29,0	49,0	39,5	40	55	4,0	0,4
	STTC R/L 10CA-11	60°	9,0	10	3,0	30	28,0	48,0	39,5	40	55	4,0	0,4
	STWC R/L 10CA-11	60°	10,6	10	3,0	24	27,0	47,0	39,5	40	55	4,0	0,4
12CA 	SCFC R/L 12CA-12	90°	14,0	12	5,0	35	28,5	48,5	40,0	50	75	5,0	0,4
	SCLC R/L 12CA-12	95°	15,8	12	5,0	35	28,5	48,5	40,0	50	75	5,0	0,4
	SSKC R/L 12CA-12	75°	13,5	12	5,0	35	36,0	56,0	40,0	50	75	5,0	0,4
	SSSC R/L 12CA-12	45°	13,0	12	5,0	27	31,5	51,5	39,0	50	75	5,0	0,4
	STFC R/L 12CA-16	90°	13,0	12	5,0	35	33,2	53,2	40,0	50	75	5,0	0,4
	STGC R/L 12CA-16	90°	15,0	12	5,0	35	31,0	51,0	40,0	50	75	5,0	0,4
	STSC R/L 12CA-16	45°	13,0	12	5,0	27	35,0	55,0	43,0	50	75	5,0	0,4
	STTC R/L 12CA-16	60°	13,0	12	5,0	35	33,0	53,0	40,0	50	75	5,0	0,4
	STWC R/L 12CA-16	60°	13,0	12	5,0	27	32,0	52,0	40,0	50	75	5,0	0,4
16CA 	SSKC R/L 16CA-12	75°	16,5	16	5,0	38	34,0	60,0	49,0	55	-	6,0	0,4
	SSSC R/L 16CA-12	45°		16	5,0	28	36,0	61,0	42,0	55	75	6,0	0,4
	STFC R/L 16CA-16	90°	17,0	16	5,0	38	36,0	61,0	52,0	55	-	5,0	0,4
	STGC R/L 16CA-16	90°	18,5	16	5,0	38	32,0	57,0	48,0	60	75	6,0	0,4
	STSC R/L 16CA-16	45°	16,5	16	5,0	28	35,5	60,5	48,0	55	-	6,0	0,4
	STTC R/L 16CA-16	60°	17,5	16	5,0	38	35,5	60,5	48,0	60	75	6,0	0,4
STWC R/L 16CA-16	60°	16,5	16	5,0	28	32,5	57,5	46,0	55	-	6,0	0,4	

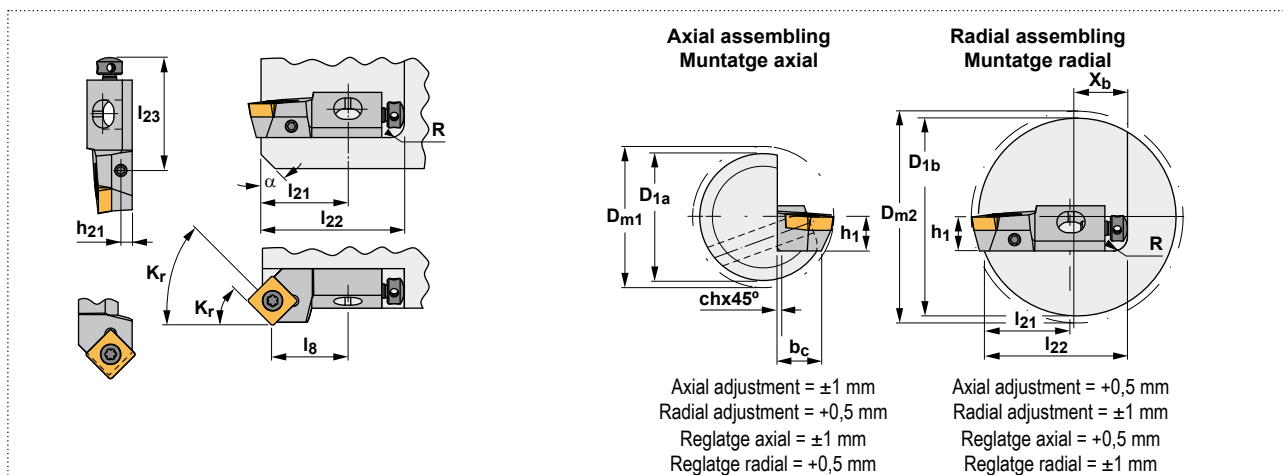



Code system / Codificació (ISO)

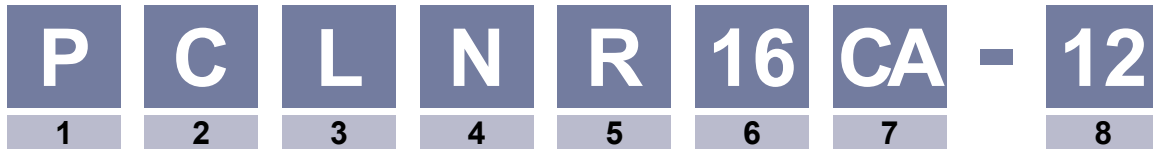

1 *Clamping method of insert*
Sistema de fixació de la plaqueta

2 *Insert shape*
Forma de la plaqueta

4 *Clearance angle of insert*
Angle d'incidència de la plaqueta

6 *Cutting edge height*
Alçada de l'aresta de tall

h1		
6	8	10
12	16	20
25		

3 *Holder style*
Tipus d'eina

5 *Hand*
Direcció de tall

7 *Cartridge code*
Codi de cartutx

C	A
C (Cartridge) C (Cartutx)	A (ISO5611)

8 *Cutting edge length*
Mida de l'aresta de tall

Lever lock cartridges
Cartutxos amb fixació per palanca

<p>PCFN 90°</p> <p>Page CN.. 1204.. Pàgina A254 CN.. 1606..</p>	<p>PCLN 95°</p> <p>Page CN.. 1204.. Pàgina A254 CN.. 1606..</p>	<p>PSKN 75°</p> <p>Page SNM.. 1204.. Pàgina A255 SNM.. 1506..</p>	<p>PSRN 75°</p> <p>Page SNM.. 1204.. Pàgina A255 SNM.. 1204..</p>	<p>PSSN 45°</p> <p>Page SNM.. 1204.. Pàgina A256 SNM.. 1204..</p>
<p>PTFN 90°</p> <p>Page TNM.. 1604.. Pàgina A256 TNM.. 2204..</p>	<p>PTGN 90°</p> <p>Page TNM.. 1604.. Pàgina A257 TNM.. 2204..</p>	<p>PTSN 45°</p> <p>Page TNM.. 1604.. Pàgina A257 TNM.. 2204..</p>	<p>PTTN 60°</p> <p>Page TNM.. 1604.. Pàgina A258 TNM.. 2204..</p>	<p>PTWN 30°</p> <p>Page TNM.. 1604.. Pàgina A258 TNM.. 2204..</p>

Top clamp cartridges
Cartutxos amb fixació per brida superior

<p>CSKP 75°</p> <p>Page SP.. 0903.. Pàgina A259 SP.. 1203..</p>	<p>CSSP 45°</p> <p>Page SP.. 0903.. Pàgina A259 SP.. 1203..</p>	<p>CTFP 90°</p> <p>Page TP.. 1103.. Pàgina A260 TP.. 1603..</p>	<p>CTGP 90°</p> <p>Page TP.. 1103.. Pàgina A260 TP.. 1603..</p>	<p>CTSP 45°</p> <p>Page TP.. 1103.. Pàgina A261 TP.. 1603..</p>
<p>CTTP 60°</p> <p>Page TP.. 1103.. Pàgina A261 TP.. 1603..</p>	<p>CTWP 30°</p> <p>Page TP.. 1103.. Pàgina A262 TP.. 1603..</p>			

Center screw cartridges
Cartutxos amb fixació per cargol central

<p>SCFC 90°</p> <p>CC.. 0602.. CC.. 09T3.. CC.. 1204.. Page Pàgina A263</p>	<p>SCLC 95°</p> <p>CC.. 0602.. CC.. 09T3.. CC.. 1204.. Page Pàgina A263</p>	<p>SSKC 75°</p> <p>Page SC.. 09T3.. Pàgina A264 SC.. 1204..</p>	<p>SSSC 45°</p> <p>Page SC.. 09T3.. Pàgina A264 SC.. 1204..</p>	<p>STFC 90°</p> <p>TC.. 0902.. TC.. 1102.. TC.. 16T3.. Page Pàgina A265</p>
<p>STGC 90°</p> <p>TC.. 0902.. TC.. 1102.. TC.. 16T3.. Page Pàgina A265</p>	<p>STSC 45°</p> <p>TC.. 0902.. TC.. 1102.. TC.. 16T3.. Page Pàgina A266</p>	<p>STTC 60°</p> <p>TC.. 0902.. TC.. 1102.. TC.. 16T3.. Page Pàgina A266</p>	<p>STWC 60°</p> <p>TC.. 1102.. TC.. 16T3.. Page Pàgina A267</p>	



Characteristics:
Cartridge equipped with rhombic negative inserts (angle 80°) and strong cutting edges.
Axial -6°
Radial -8°

Característiques:
Cartutx equipat amb plaquetes ròmbiques negatives (angle 80°) amb arestes de tall reforçades.

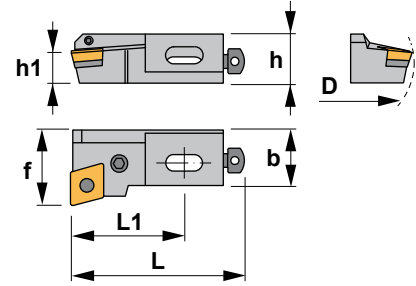

PCFN 90°

Reference Referència	D	h	h1	L	L1	f	b	Insert size Mida plaqueta	KG
PCFN R/L 16CA-12	60	25	16	63	38	25	20	CNM.. 1204..	0,140
PCFN R/L 20CA-12	70	30	20	70	40	25	20	CNM.. 1204..	0,170
PCFN R/L 25CA-16	100	35	25	100	50	32	25	CNM.. 1606..	0,380

Reference Referència													Nm
PCFN R/L 16CA-12	8312	1648	5003	3612	4112	1406	1505	0012	5025	2808	1808	5005	3.0
PCFN R/L 20CA-12	8012	1608	5003	3612	4112	1406	1506	0012	5003	2808	1808	5005	3.0
PCFN R/L 25CA-16	8016	1618	5003	3616	4115	1408	1508	0015	5004	2810	1810	5006	3.0

CN.. 80° rhombic negative inserts. Plaquetes ròmbiques negatives 80°. A32-34

Reference / Ref.	l	s	d
CN.. 1204..	12,90	4,76	12,70
CN.. 1606..	16,10	6,35	15,88

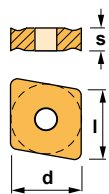

CNMG-CC **CNMG-FC** **CNMG-MC** **CNMG-MHC** **CNMG-RC**



More inserts / Altres plaquetes: CNGP, CNMA, CNMG-KC, CNMG-FMC, CNMG-MFC, CNMG-TC, CNMM.



Characteristics:
Cartridge equipped with rhombic negative double-sided insert (angle 80°) with strong cutting edge.
Axial -6°
Radial -6°

Característiques:
Cartutx equipat amb plaquetes ròmbiques negatives de doble cara (angle 80°) amb arestes de tall reforçades.

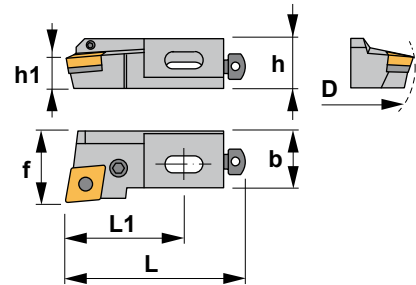

PCLN 95°

Reference Referència	D	h	h1	L	L1	f	b	Insert size Mida plaqueta	KG
PCLN R/L 16CA-12	60	25	16	63	38	25	20	CNM.. 1204..	0,135
PCLN R/L 20CA-12	70	30	20	70	40	25	20	CNM.. 1204..	0,160
PCLN R/L 25CA-16	100	35	25	100	50	32	25	CNM.. 1606..	0,375

Reference Referència													Nm
PCLN R/L 16CA-12	8312	1648	5003	3612	4112	1406	1505	0012	5025	2808	1808	5005	3.0
PCLN R/L 20CA-12	8012	1608	5003	3612	4112	1406	1506	0012	5003	2808	1808	5005	3.0
PCLN R/L 25CA-16	8016	1618	5003	3616	4115	1408	1508	0015	5004	2810	1810	5006	3.0

CN.. 80° rhombic negative inserts. Plaquetes ròmbiques negatives 80°. A32-34

Reference / Ref.	l	s	d
CN.. 1204..	12,90	4,76	12,70
CN.. 1606..	16,10	6,35	15,88

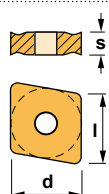

CNMG-CC **CNMG-FC** **CNMG-MC** **CNMG-MHC** **CNMG-RC**



More inserts / Altres plaquetes: CNGP, CNMA, CNMG-KC, CNMG-FMC, CNMG-MFC, CNMG-TC, CNMM.



Characteristics:
 Cartridge equipped with square negative inserts and strong cutting edges.
 Axial -4°
 Radial -4°

Característiques:
 Cartutx equipat amb plaquetes quadrades negatives amb arestes de tall reforçades.

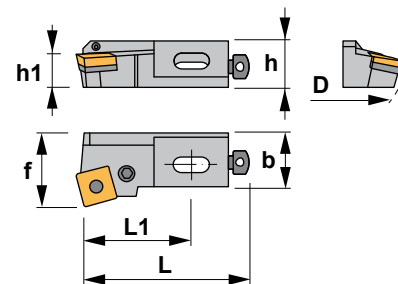

PSKN 75°

Reference Referència	D	h	h1	L	L1	f	b	Insert size Mida plaqueta	Kg
PSKN R/L 12CA-12	50	20	12	55	35	20	16	SNM.. 1204..	0,080
PSKN R/L 16CA-12	60	25	16	63	38	25	20	SNM.. 1204..	0,135
PSKN R/L 20CA-12	70	30	20	70	40	25	20	SNM.. 1204..	0,180
PSKN R/L 25CA-15	100	35	25	100	50	32	25	SNM.. 1506..	0,400

Reference Referència												Nm	
PSKN R/L 12CA-12	8212	1626	5025	-	-	1405	1505	-	5025	2806	1806	5004	2.0
PSKN R/L 16CA-12	8312	1648	5003	3512	4112	1406	1505	0012	5025	2808	1808	5005	3.0
PSKN R/L 20CA-12	8012	1608	5003	3512	4112	1406	1506	0012	5003	2808	1808	5005	3.0
PSKN R/L 25CA-15	8016	1618	5003	3515	4115	1408	1508	0015	5004	2810	1810	5006	3.0

SNM..

Square negative inserts.
 Plaquetes quadrades negatives. A41-42

Reference / Ref.	l	s	d
SNM.. 1204..	12,70	4,76	12,70
SNM.. 1506..	15,88	6,35	15,88

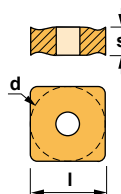

Characteristics:
 Cartridge equipped with square negative inserts and strong cutting edges.
 Axial -11,25°
 Radial -3,25°

Característiques:
 Cartutx equipat amb plaquetes quadrades negatives amb arestes de tall reforçades.

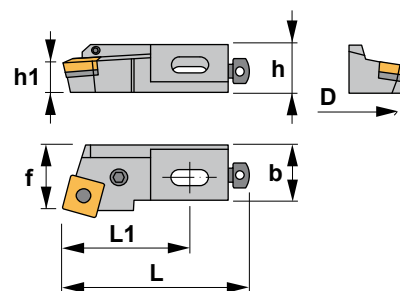

PSRN 75°

Reference Referència	D	h	h1	L	L1	f	b	Insert size Mida plaqueta	Kg
PSRN R/L 16CA-12	60	25	16	63	38	25	20	SNM.. 1204..	0,135
PSRN R/L 20CA-12	70	30	20	70	40	25	20	SNM.. 1204..	0,180

Reference Referència												Nm	
PSRN R/L 16CA-12	8312	1648	5003	3512	4112	1406	1505	0012	5025	2808	1808	5005	3.0
PSRN R/L 20CA-12	8012	1608	5003	3512	4112	1406	1506	0012	5003	2808	1808	5005	3.0

SNM..

Square negative inserts.
 Plaquetes quadrades negatives. A41-42

Reference / Ref.	l	s	d
SNM.. 1204..	12,70	4,76	12,70

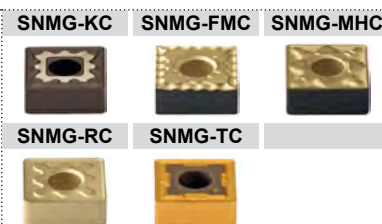
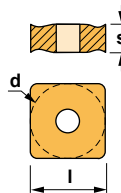



Characteristics:
Cartridge equipped with square negative inserts and strong cutting edges.
Axial -7°
Radial -7°

Característiques:
Cartutx equipat amb plaquetes quadrades negatives amb arestes de tall reforçades.

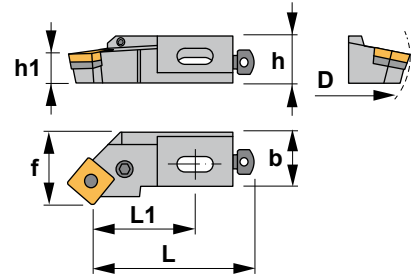

PSSN 45°

Reference Referència	D	h	h1	L	L1	f	b	Insert size Mida plaqueta	
PSSN R/L 12CA-12	50	20	12	47	27	20	16	SNM.. 1204..	0,070
PSSN R/L 16CA-12	60	25	16	53	28	25	20	SNM.. 1204..	0,110
PSSN R/L 20CA-12	70	30	20	60	30	25	20	SNM.. 1204..	0,140

Reference Referència												Nm	
PSSN R/L 12CA-12	8212	1626	5025	-	-	1405	1505	-	5025	2806	1806	5004	2.0
PSSN R/L 16CA-12	8312	1648	5003	3512	4112	1406	1505	0012	5025	2808	1808	5005	3.0
PSSN R/L 20CA-12	8012	1608	5003	3512	4112	1406	1506	0012	5003	2808	1808	5005	3.0

SNM..

Square negative inserts.
Plaquetes quadrades negatives. A41-42

Reference / Ref.	l	s	d
SNM.. 1204..	12,70	4,76	12,70

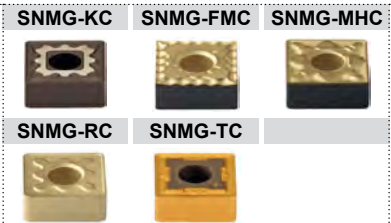
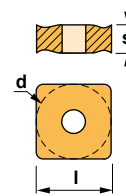

Characteristics:
Cartridge equipped with triangular negative inserts and strong cutting edges.
Axial -6°
Radial -8°

Característiques:
Cartutx equipat amb plaquetes triangulars negatives amb arestes de tall reforçades.

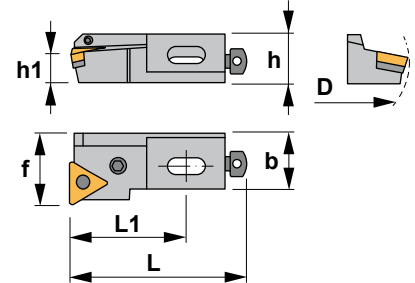

PTFN 90°

Reference Referència	D	h	h1	L	L1	f	b	Insert size Mida plaqueta	
PTFN R/L 12CA-16	50	20	12	55	35	20	16	TNM.. 1604..	0,080
PTFN R/L 16CA-16	60	25	16	63	38	25	20	TNM.. 1604..	0,120
PTFN R/L 20CA-22	70	30	20	70	40	25	20	TNM.. 2204..	0,160
PTFN R/L 25CA-22	100	35	25	100	50	32	25	TNM.. 2204..	0,400

Reference Referència												Nm	
PTFN R/L 12CA-16	8216	1605	5002	-	-	1405	1505	-	5025	2806	1806	5004	1.4
PTFN R/L 16CA-16	8009	1606	5025	3416	4109	1406	1505	0009	5025	2808	1808	5005	2.0
PTFN R/L 20CA-22	8012	1608	5003	3422	4112	1406	1506	0012	5003	2808	1808	5005	3.0
PTFN R/L 25CA-22	8012	1608	5003	3422	4112	1408	1508	0012	5004	2810	1810	5006	3.0

TNM..

Triangular negative inserts.
Plaquetes triangulars negatives. A45-46

Reference / Ref.	l	s	d
TNM.. 1604..	16,50	4,76	9,52
TNM.. 2204..	22,00	4,76	12,70

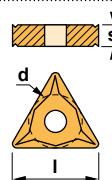



Characteristics:

Cartridge equipped with triangular negative inserts and strong cutting edges.

Axial -6°
 Radial -10°

Característiques:

Cartutx equipat amb plaquetes triangulars negatives amb arestes de tall reforçades.

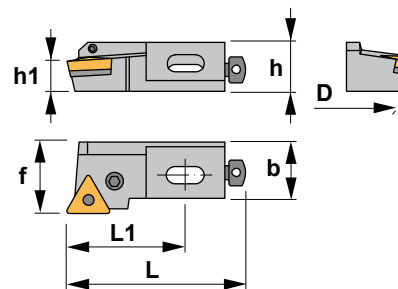

PTGN 90°

Reference Referència	D	h	h1	L	L1	f	b	Insert size Mida plaqueta	⚖️
PTGN R/L 12CA-16	50	20	12	55	35	20	16	TNM.. 1604..	0,080
PTGN R/L 16CA-16	60	25	16	63	38	25	20	TNM.. 1604..	0,120
PTGN R/L 20CA-22	70	30	20	70	40	25	20	TNM.. 2204..	0,160

Reference Referència												Nm	
PTGN R/L 12CA-16	8216	1605	5002	-	-	1405	1505	-	5025	2806	1806	5004	1.4
PTGN R/L 16CA-16	8009	1606	5025	3416	4109	1406	1505	0009	5025	2808	1808	5005	2.0
PTGN R/L 20CA-22	8012	1608	5003	3422	4112	1406	1506	0012	5003	2808	1808	5005	3.0

TNM..

Triangular negative inserts.
 Plaquetes triangulars negatives. ⓘ A45-46

Reference / Ref.	l	s	d
TNM.. 1604..	16,50	4,76	9,52
TNM.. 2204..	22,00	4,76	12,70

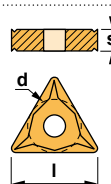

TNMG-FC	TNMG-MC
More inserts / Altres plaquetes: TNMA, TNMG-CC, TNMG-FMC, TNMG-KC, TNMG-MFC, TNMG-MHC, TNMG-TC, TNMX.	



Characteristics:

Cartridge equipped with triangular negative inserts and strong cutting edges.

Axial -7,75°
 Radial -7,75°

Característiques:

Cartutx equipat amb plaquetes triangulars negatives amb arestes de tall reforçades.

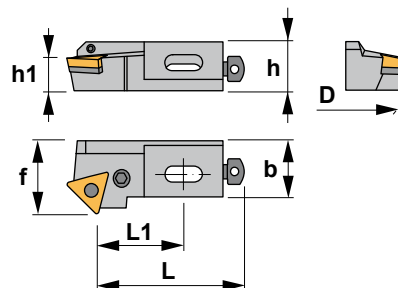

PTSN 45°

Reference Referència	D	h	h1	L	L1	f	b	Insert size Mida plaqueta	⚖️
PTSN R/L 12CA-16	50	20	12	47	27	20	16	TNM.. 1604..	0,070
PTSN R/L 16CA-16	60	25	16	53	28	25	20	TNM.. 1604..	0,130
PTSN R/L 20CA-22	70	30	20	60	30	25	20	TNM.. 2204..	0,165
PTSN R/L 25CA-22	100	35	25	67	37	32	25	TNM.. 2204..	0,330

Reference Referència												Nm	
PTSN R/L 12CA-16	8216	1605	5002	-	-	1405	1505	-	5025	2806	1806	5004	1.4
PTSN R/L 16CA-16	8009	1606	5025	3416	4109	1406	1505	0009	5025	2808	1808	5005	2.0
PTSN R/L 20CA-22	8012	1608	5003	3422	4112	1406	1506	0012	5003	2808	1808	5005	3.0
PTSN R/L 25CA-22	8012	1608	5003	3422	4112	1408	1508	0012	5004	2810	1810	5006	3.0

TNM..

Triangular negative inserts.
 Plaquetes triangulars negatives. ⓘ A45-46

Reference / Ref.	l	s	d
TNM.. 1604..	16,50	4,76	9,52
TNM.. 2204..	22,00	4,76	12,70

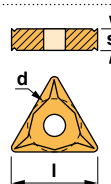

TNMG-FC	TNMG-MC
More inserts / Altres plaquetes: TNMA, TNMG-CC, TNMG-FMC, TNMG-KC, TNMG-MFC, TNMG-MHC, TNMG-TC, TNMX.	



Characteristics:
Cartridge equipped with triangular negative inserts and strong cutting edges.
Axial -6°
Radial -10°

Característiques:
Cartutx equipat amb plaquetes triangulars negatives amb arestes de tall reforçades.

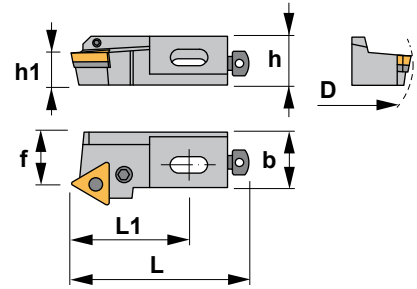

PTTN 60°

Reference Referència	D	h	h1	L	L1	f	b	Insert size Mida plaqueta	KG
PTTN R/L 12CA-16	50	20	12	55	35	13	16	TNM.. 1604..	0,135
PTTN R/L 16CA-16	60	25	16	63	38	15	20	TNM.. 1604..	0,120
PTTN R/L 20CA-22	70	30	20	70	40	15	20	TNM.. 2204..	0,160

Reference Referència													Nm
PTTN R/L 12CA-16	8216	1605	5002	-	-	1405	1505	-	5025	2806	1806	5004	1.4
PTTN R/L 16CA-16	8009	1606	5025	3416	4109	1406	1505	0009	5025	2808	1808	5005	2.0
PTTN R/L 20CA-22	8012	1608	5003	3422	4112	1406	1506	0012	5003	2808	1808	5005	3.0

TNM..

Triangular negative inserts.
Plaquetes triangulars negatives. A45-46

Reference / Ref.	l	s	d
TNM.. 1604..	16,50	4,76	9,52
TNM.. 2204..	22,00	4,76	12,70

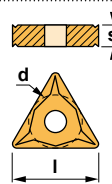

TNMG-FC

TNMG-MC



More inserts / Altres plaquetes: TNMA, TNMG-CC, TNMG-FMC, TNMG-KC, TNMG-MFC, TNMG-MHC, TNMG-TC, TNMX.



Characteristics:
Cartridge equipped with triangular negative inserts and strong cutting edges.
Axial -6°
Radial -10°

Característiques:
Cartutx equipat amb plaquetes triangulars negatives amb arestes de tall reforçades.

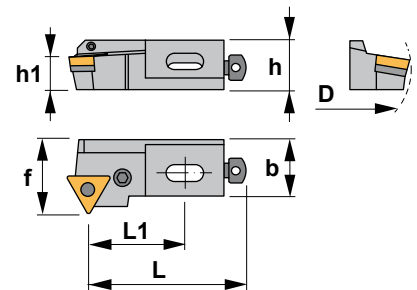

PTWN 30°

Reference Referència	D	h	h1	L	L1	f	b	Insert size Mida plaqueta	KG
PTWN R/L 12CA-16	50	20	12	47	27	20	16	TNM.. 1604..	0,080
PTWN R/L 16CA-16	60	25	16	53	28	25	20	TNM.. 1604..	0,130
PTWN R/L 20CA-22	70	30	20	60	30	25	20	TNM.. 2204..	0,165

Reference Referència													Nm
PTWN R/L 12CA-16	8216	1605	5002	-	-	1405	1505	-	5025	2806	1806	5004	1.4
PTWN R/L 16CA-16	8009	1606	5025	3416	4109	1406	1505	0009	5025	2808	1808	5005	2.0
PTWN R/L 20CA-22	8012	1608	5003	3422	4112	1406	1506	0012	5003	2808	1808	5005	3.0

TNM..

Triangular negative inserts.
Plaquetes triangulars negatives. A45-46

Reference / Ref.	l	s	d
TNM.. 1604..	16,50	4,76	9,52
TNM.. 2204..	22,00	4,76	12,70

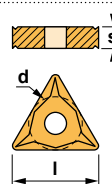

TNMG-FC

TNMG-MC



More inserts / Altres plaquetes: TNMA, TNMG-CC, TNMG-FMC, TNMG-KC, TNMG-MFC, TNMG-MHC, TNMG-TC, TNMX.



Characteristics:
 Cartridge equipped with square positive inserts and strong cutting edges.
 Axial 5,75°
 Radial 1,50°

Característiques:
 Cartutx equipat amb plaquetes quadrades positives amb arestes de tall reforçades.

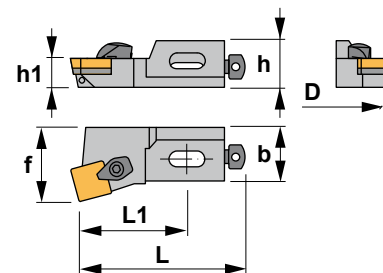

CSKP 75°

Reference Referència	D	h	h1	L	L1	f	b	Insert size Mida plaqueta	Kg
CSKP R/L 10CA-09	40	15	10	50	30	14	11	SP..0903..	0,035
CSKP R/L 12CA-12	50	20	12	55	35	20	16	SP..1203..	0,075
CSKP R/L 16CA-12	55	25	16	63	38	25	20	SP..1203..	0,125

Reference Referència												Nm
CSKP R/L 10CA-09	2304	5025	-	-	1405	1504	5002	2806	1816	5004		2.0
CSKP R/L 12CA-12	2305	5003	-	-	1405	1505	5025	2806	1806	5004		3.0
CSKP R/L 16CA-12	2305	5003	3112	4002	1406	1505	5025	2808	1808	5005		3.0

SP..

Square positive inserts with 11° clearance. A43
 Plaquetes quadrades positives amb 11° incidència.

Reference / Ref.	l	s	d
SP.. 0903..	9,52	3,18	9,52
SP.. 1203..	12,70	3,18	12,70

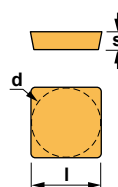

SPMR



SPUN



Characteristics:
 Cartridge equipped with square positive inserts and strong cutting edges.
 Axial 5°
 Radial 0°

Característiques:
 Cartutx equipat amb plaquetes quadrades positives amb arestes de tall reforçades.

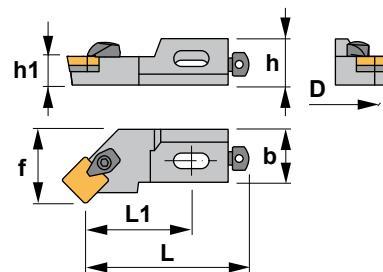

CSSP 45°

Reference Referència	D	h	h1	L	L1	f	b	Insert size Mida plaqueta	Kg
CSSP R/L 10CA-09	40	15	10	44	24	14	11	SP..0903..	0,035
CSSP R/L 12CA-12	50	20	12	47	27	20	16	SP..1203..	0,065
CSSP R/L 16CA-12	55	25	16	53	28	25	20	SP..1203..	0,090

Reference Referència												Nm
CSSP R/L 10CA-09	2304	5025	-	-	1405	1504	5002	2806	1816	5004		2.0
CSSP R/L 12CA-12	2305	5003	-	-	1405	1505	5025	2806	1806	5004		3.0
CSSP R/L 16CA-12	2305	5003	3112	4002	1406	1505	5025	2808	1808	5005		3.0

SP..

Square positive inserts with 11° clearance. A43
 Plaquetes quadrades positives amb 11° incidència.

Reference / Ref.	l	s	d
SP.. 0903..	9,52	3,18	9,52
SP.. 1203..	12,70	3,18	12,70

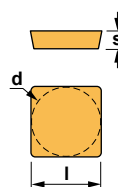

SPMR



SPUN





Characteristics:

Cartridge equipped with triangular positive inserts and strong cutting edges.

Axial 6°
Radial 0°

Característiques:

Cartutx equipat amb plaquetes triangulars positives amb arestes de tall reforçades.

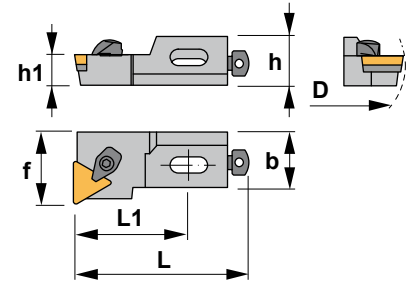

CTFP 90°

Reference Referència	D	h	h1	L	L1	f	b	Insert size Mida plaqueta	Kg
CTFP R/L 10CA-11	40	15	10	50	30	14	11	TP..1103..	0,035
CTFP R/L 12CA-16	50	20	12	55	35	20	16	TP..1603..	0,080
CTFP R/L 16CA-16	55	25	16	63	38	25	20	TP..1603..	0,120

Reference Referència										Nm	
CTFP R/L 10CA-11	2304	5025	-	-	1405	1504	5002	2806	1816	5004	2.0
CTFP R/L 12CA-16	2305	5003	-	-	1405	1505	5025	2806	1806	5004	3.0
CTFP R/L 16CA-16	2305	5003	3116	4002	1406	1505	5025	2808	1808	5005	3.0

TP.. Triangular positive inserts with 11° clearance. A47
Plaquetes triangulars positives amb 11° incidència.

Reference / Ref.	l	s	d
TP.. 1103..	11,00	3,18	6,35
TP.. 1603..	16,50	3,18	9,52

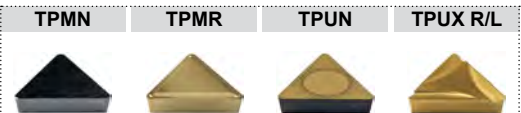
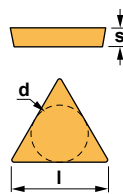

Characteristics:

Cartridge equipped with triangular positive inserts and strong cutting edges.

Axial 0°
Radial 4°

Característiques:

Cartutx equipat amb plaquetes triangulars positives amb arestes de tall reforçades.

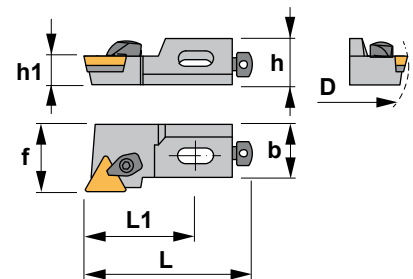

CTGP 90°

Reference Referència	D	h	h1	L	L1	f	b	Insert size Mida plaqueta	Kg
CTGP R/L 10CA-11	40	15	10	50	30	14	11	TP..1103..	0,035
CTGP R/L 12CA-16	50	20	12	55	35	20	16	TP..1603..	0,070
CTGP R/L 16CA-16	60	25	16	63	38	25	20	TP..1603..	0,115

Reference Referència										Nm	
CTGP R/L 10CA-11	2304	5025	-	-	1405	1504	5002	2806	1816	5004	2.0
CTGP R/L 12CA-16	2305	5003	-	-	1405	1505	5025	2806	1806	5004	3.0
CTGP R/L 16CA-16	2305	5003	3116	4002	1406	1505	5025	2808	1808	5005	3.0

TP.. Triangular positive inserts with 11° clearance. A47
Plaquetes triangulars positives amb 11° incidència.

Reference / Ref.	l	s	d
TP.. 1103..	11,00	3,18	6,35
TP.. 1603..	16,50	3,18	9,52

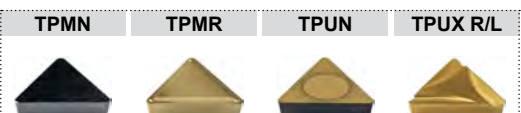
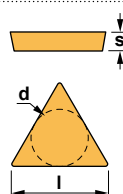



Characteristics:
 Cartridge equipped with triangular positive inserts and strong cutting edges.
 Axial 3,50°
 Radial 3,50°

Característiques:
 Cartutx equipat amb plaquetes triangulars positives amb arestes de tall reforçades.

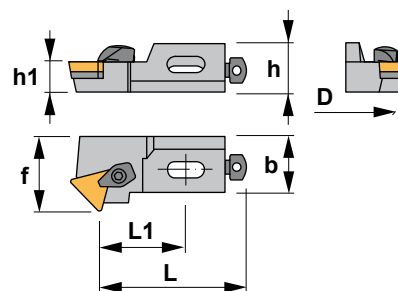

CTSP 45°

Reference Referència	D	h	h1	L	L1	f	b	Insert size Mida plaqueta	Kg
CTSP R/L 10CA-11	40	15	10	44	24	14	11	TP..1103..	0,035
CTSP R/L 12CA-16	50	20	12	47	27	20	16	TP..1603..	0,075
CTSP R/L 16CA-16	55	25	16	53	28	25	20	TP..1603..	0,140

Reference Referència										Nm	
CTSP R/L 10CA-11	2304	5025	-	-	1405	1504	5002	2806	1816	5004	2.0
CTSP R/L 12CA-16	2305	5003	-	-	1405	1505	5025	2806	1806	5004	3.0
CTSP R/L 16CA-16	2305	5003	3116	4002	1406	1505	5025	2808	1808	5005	3.0

TP.. Triangular positive inserts with 11° clearance. A47
 Plaquetes triangulars positives amb 11° incidència.

Reference / Ref.	l	s	d
TP.. 1103..	11,00	3,18	6,35
TP.. 1603..	16,50	3,18	9,52

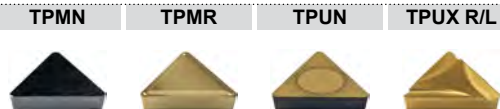
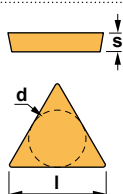

Characteristics:
 Cartridge equipped with triangular positive inserts and strong cutting edges.
 Axial 0°
 Radial 4°

Característiques:
 Cartutx equipat amb plaquetes triangulars positives amb arestes de tall reforçades.

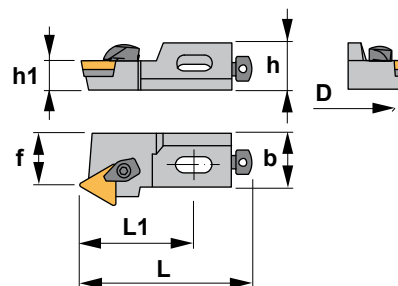

CTTP 60°

Reference Referència	D	h	h1	L	L1	f	b	Insert size Mida plaqueta	Kg
CTTP R/L 10CA-11	40	15	10	50	30	9	11	TP..1103..	0,040
CTTP R/L 12CA-16	50	20	12	55	35	13	16	TP..1603..	0,075
CTTP R/L 16CA-16	55	25	16	63	38	15	20	TP..1603..	0,115

Reference Referència										Nm	
CTTP R/L 10CA-11	2304	5025	-	-	1405	1504	5002	2806	1816	5004	2.0
CTTP R/L 12CA-16	2305	5003	-	-	1405	1505	5025	2806	1806	5004	3.0
CTTP R/L 16CA-16	2305	5003	3116	4002	1406	1505	5025	2808	1808	5005	3.0

TP.. Triangular positive inserts with 11° clearance. A47
 Plaquetes triangulars positives amb 11° incidència.

Reference / Ref.	l	s	d
TP.. 1103..	11,00	3,18	6,35
TP.. 1603..	16,50	3,18	9,52

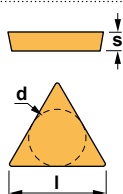



Characteristics:

Cartridge equipped with triangular positive inserts and strong cutting edges.
Axial 5,25°
Radial 3°

Característiques:

Cartutx equipat amb plaquetes triangulars positives amb arestes de tall reforçades.

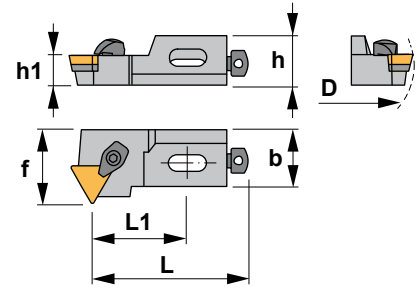

CTWP 30°

Reference Referència	D	h	h1	L	L1	f	b	Insert size Mida plaqueta	Kg
CTWP R/L 10CA-11	40	15	10	44	24	14	11	TP..1103..	0,035
CTWP R/L 12CA-16	50	20	12	47	27	20	16	TP..1603..	0,065
CTWP R/L 16CA-16	55	25	16	53	28	25	20	TP..1603..	0,105

Reference Referència											Nm
CTWP R/L 10CA-11	2304	5025	-	-	1405	1504	5002	2806	1816	5004	2.0
CTWP R/L 12CA-16	2305	5003	-	-	1405	1505	5025	2806	1806	5004	3.0
CTWP R/L 16CA-16	2305	5003	3116	4002	1406	1505	5025	2808	1808	5005	3.0

TP.. Triangular positive inserts with 11° clearance. A47
Plaquetes triangulars positives amb 11° incidència.

Reference / Ref.	l	s	d
TP.. 1103..	11,00	3,18	6,35
TP.. 1603..	16,50	3,18	9,52

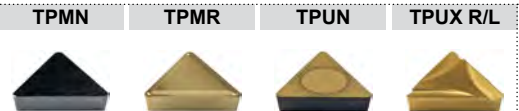
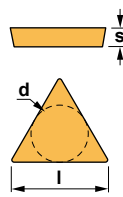



Characteristics:
 Cartridge equipped with rhombic positive insert (angle 80°).
 Axial 0°
 Radial 0°

Característiques:
 Cartutx equipat amb plaqueta ròmbica positiva (angle 80°).

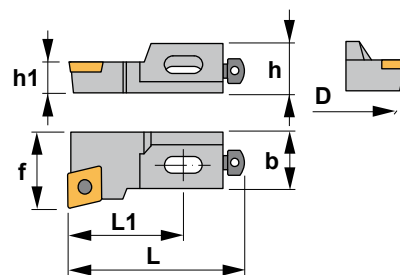

SCFC 90°

Reference Referència	D	h	h1	L	L1	f	b	Insert size Mida plaqueta	
SCFC R/L 06CA-06	20	8	6	25	13,5	10	5,0	CCM.. 0602..	0,005
SCFC R/L 08CA-06	25	11	8	27	15,0	10	7,5	CCM.. 0602..	0,010
SCFC R/L 10CA-09	30	14	10	42	24,0	14	10,0	CCM.. 09T3..	0,030
SCFC R/L 12CA-12	40	16	12	47	35,0	20	14,0	CCM.. 1204..	0,060

Reference Referència									Nm
SCFC R/L 06CA-06	1425	5507	1403	1503	5015	2803	1803	5002	0.9
SCFC R/L 08CA-06	1425	5507	1404	1503	5015	2804	1804	5025	0.9
SCFC R/L 10CA-09	1440	5515	1405	1504	5002	2806	1806	5004	3.0
SCFC R/L 12CA-12	1250	5520	1405	1505	5025	2806	1806	5004	4.0

CC.. 80° rhombic positive inserts with 7° clearance. A30-31
 Plaquetes ròmbiques positives 80° amb 7° incidència.

Reference / Ref.	l	s	d
CC.. 0602..	6,45	2,38	6,35
CC.. 09T3..	9,65	3,97	9,52
CC.. 1204..	12,90	4,76	12,70

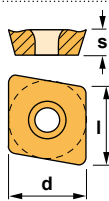

Characteristics:
 Cartridge equipped with rhombic positive insert (angle 80°).
 Axial 0°
 Radial 0°

Característiques:
 Cartutx equipat amb plaqueta ròmbica positiva (angle 80°).

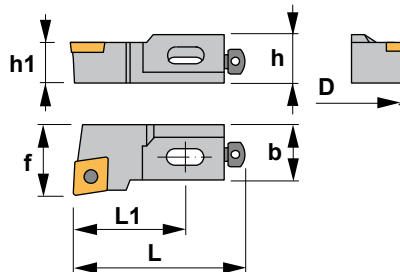

SCLC 95°

Reference Referència	D	h	h1	L	L1	f	b	Insert size Mida plaqueta	
SCLC R/L 06CA-06	20	8	6	25	13,5	10	5,0	CCM.. 0602..	0,005
SCLC R/L 08CA-06	25	11	8	27	15,0	12	7,5	CCM.. 0602..	0,010
SCLC R/L 10CA-09	30	14	10	42	24,0	14	10,0	CCM.. 09T3..	0,030
SCLC R/L 12CA-12	40	16	12	47	35,0	20	14,0	CCM.. 1204..	0,060

Reference Referència									Nm
SCLC R/L 06CA-06	1425	5507	1403	1503	5015	2803	1803	5002	0.9
SCLC R/L 08CA-06	1425	5507	1404	1503	5015	2804	1804	5025	0.9
SCLC R/L 10CA-09	1440	5515	1405	1504	5002	2806	1806	5004	3.0
SCLC R/L 12CA-12	1250	5520	1405	1505	5025	2806	1806	5004	4.0

CC.. 80° rhombic positive inserts with 7° clearance. A30-31
 Plaquetes ròmbiques positives 80° amb 7° incidència.

Reference / Ref.	l	s	d
CC.. 0602..	6,45	2,38	6,35
CC.. 09T3..	9,65	3,97	9,52
CC.. 1204..	12,90	4,76	12,70

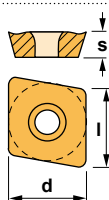



Characteristics:
Cartridge equipped with square positive inserts.
Axial -6°
Radial -10°

Característiques:
Cartutx equipat amb plaquetes quadrades positives.

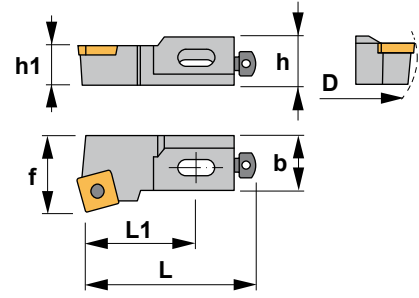

SSKC 75°

Reference Referència	D	h	h1	L	L1	f	b	Insert size Mida plaqueta	
SSKC R/L 10CA-09	30	14	10	50	30	14	10,0	SC.. 09T3..	0,030
SSKC R/L 12CA-12	40	16	12	55	35	20	14,0	SC.. 1204..	0,065
SSKC R/L 16CA-12	50	20	16	63	38	25	17,5	SC.. 1204..	0,115

Reference Referència									Nm
SSKC R/L 10CA-09	1440	5515	1405	1504	5002	2806	1816	5004	3.0
SSKC R/L 12CA-12	1250	5520	1405	1505	5025	2806	1806	5004	4.0
SSKC R/L 16CA-12	1250	5520	1406	1505	5025	2808	1808	5005	4.0

SC.. Square positive inserts with 7° clearance. A40
Plaquetes quadrades positives amb 7° incidència.

Reference / Ref.	l	s	d
SC.. 09T3..	9,52	3,97	9,52
SC.. 1204..	12,70	4,76	12,70

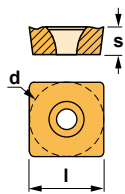

SCGT-AL **SCMT** **SCMT-39** **SCMW**



Characteristics:
Cartridge equipped with square positive inserts.
Axial -3,5°
Radial -3,5°

Característiques:
Cartutx equipat amb plaquetes quadrades positives.

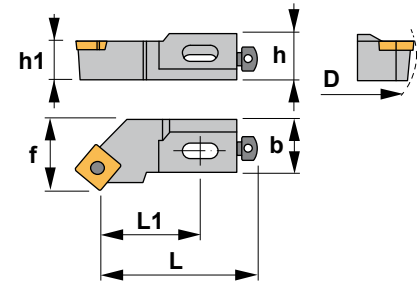

SSSC 45°

Reference Referència	D	h	h1	L	L1	f	b	Insert size Mida plaqueta	
SSSC R/L 10CA-09	30	14	10	44	24	14	10,0	SC.. 09T3..	0,030
SSSC R/L 12CA-12	40	16	12	47	27	20	14,0	SC.. 1204..	0,055
SSSC R/L 16CA-12	50	20	16	53	28	25	17,5	SC.. 1204..	0,090

Reference Referència									Nm
SSSC R/L 10CA-09	1440	5515	1405	1504	5002	2806	1816	5004	3.0
SSSC R/L 12CA-12	1250	5520	1405	1505	5025	2806	1806	5004	4.0
SSSC R/L 16CA-12	1250	5520	1406	1505	5025	2808	1808	5005	4.0

SC.. Square positive inserts with 7° clearance. A40
Plaquetes quadrades positives amb 7° incidència.

Reference / Ref.	l	s	d
SC.. 09T3..	9,52	3,97	9,52
SC.. 1204..	12,70	4,76	12,70

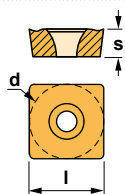

SCGT-AL **SCMT** **SCMT-39** **SCMW**





Characteristics:

Cartridge for face turning applications equipped with triangular positive inserts.
 Axial 0°
 Radial -3°

Característiques:

Cartutx per aplicacions de refrentat equipat amb plaquetes triangulars positives.

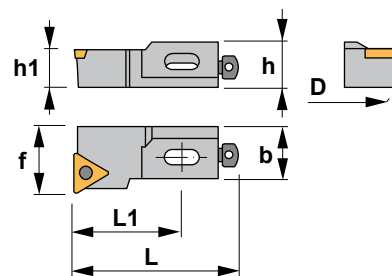

STFC 90°

Reference Referència	D	h	h1	L	L1	f	b	Insert size Mida plaqueta	KG
STFC R/L 08CA-09	25	11	8	32	15	10	7,5	TC.. 0902..	0,010
STFC R/L 08CA-11	25	11	8	32	15	11	7,5	TC.. 1102..	0,010
STFC R/L 10CA-11	30	14	10	50	30	14	10,0	TC.. 1102..	0,035
STFC R/L 12CA-16	40	16	12	55	35	20	14,0	TC.. 16T3..	0,065
STFC R/L 16CA-16	50	20	16	63	38	25	17,5	TC.. 16T3..	0,125

Reference Referència									Nm
STFC R/L 08CA-09	1222	5506	1404	1503	5015	2804	1804	5025	0.6
STFC R/L 08CA-11	1225	5507	1404	1503	5015	2804	1804	5025	0.9
STFC R/L 10CA-11	1225	5507	1405	1504	5002	2806	1816	5004	0.9
STFC R/L 12CA-16	1240	5515	1405	1505	5025	2806	1806	5004	3.0
STFC R/L 16CA-16	1240	5515	1406	1505	5025	2808	1808	5005	3.0



Characteristics:

Cartridge for face turning applications equipped with triangular positive inserts.
 Axial 0°
 Radial -3°

Característiques:

Cartutx per aplicacions de refrentat equipat amb plaquetes triangulars positives.

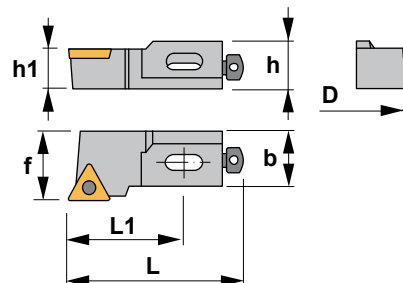

STGC 90°

Reference Referència	D	h	h1	L	L1	f	b	Insert size Mida plaqueta	KG
STGC R/L 10CA-11	30	14	10	50	30	14	10,0	TC.. 1102..	0,035
STGC R/L 12CA-16	40	16	12	55	35	20	14,0	TC.. 16T3..	0,065
STGC R/L 16CA-16	50	20	16	63	38	25	17,5	TC.. 16T3..	0,125

Reference Referència									Nm
STGC R/L 10CA-11	1225	5507	1405	1504	5002	2806	1816	5004	0.9
STGC R/L 12CA-16	1240	5515	1405	1505	5025	2806	1806	5004	3.0
STGC R/L 16CA-16	1240	5515	1406	1505	5025	2808	1808	5005	3.0

TC.. Triangular positive inserts with 7° clearance. A44
 Plaquetes triangulars positives amb 7° incidència.

Reference / Ref.	l	s	d
TC.. 0902..	9,62	2,38	5,55
TC.. 1102..	11,00	2,38	6,35
TC.. 16T3..	16,50	3,97	9,52

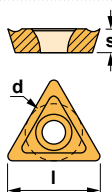



Characteristics:

Cartridge for face turning applications equipped with triangular positive inserts.
Axial -3,5°
Radial -3,5°

Característiques:

Cartutx per aplicacions de refrenat equipat amb plaquetes triangulars positives.

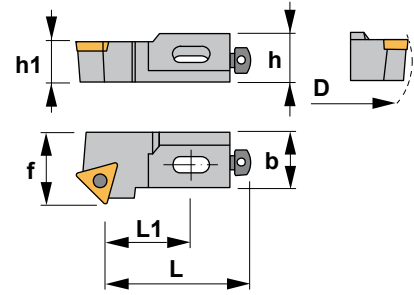

STSC 45°

Reference Referència	D	h	h1	L	L1	f	b	Insert size Mida plaqueta	
STSC R/L 08CA-09	25	11	8	28	11	10	7,5	TC.. 0902..	0,005
STSC R/L 08CA-11	25	11	8	27	10	11	7,5	TC.. 1102..	0,005
STSC R/L 10CA-11	30	14	10	44	24	14	10,0	TC.. 1102..	0,035
STSC R/L 12CA-16	40	16	12	47	27	20	14,0	TC.. 16T3..	0,065
STSC R/L 16CA-16	50	20	16	53	28	25	17,5	TC.. 16T3..	0,110

Reference Referència									Nm
STSC R/L 08CA-09	1222	5506	1404	1503	5015	2804	1804	5025	0.6
STSC R/L 08CA-11	1225	5507	1404	1503	5015	2804	1804	5025	0.9
STSC R/L 10CA-11	1225	5507	1405	1504	5002	2806	1816	5004	0.9
STSC R/L 12CA-16	1240	5515	1405	1505	5025	2806	1806	5004	3.0
STSC R/L 16CA-16	1240	5515	1406	1505	5025	2808	1808	5005	3.0



Characteristics:

Cartridge for face turning applications equipped with triangular positive inserts.
Axial -1,5°
Radial -2,5°

Característiques:

Cartutx per aplicacions de refrenat equipat amb plaquetes triangulars positives.

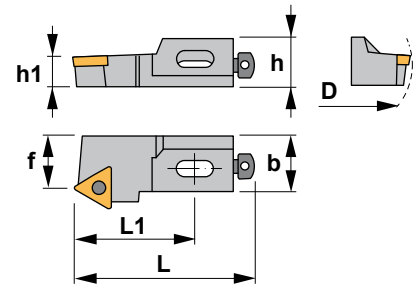

STTC 60°

Reference Referència	D	h	h1	L	L1	f	b	Insert size Mida plaqueta	
STTC R/L 08CA-09	25	11	8	32	15	6	7,5	TC.. 0902..	0,010
STTC R/L 08CA-11	25	11	8	32	15	6	7,5	TC.. 1102..	0,010
STTC R/L 10CA-11	30	14	10	50	30	14	10,0	TC.. 1102..	0,035
STTC R/L 12CA-16	40	16	12	55	35	13	14,0	TC.. 16T3..	0,065
STTC R/L 16CA-16	50	20	16	63	38	15	17,5	TC.. 16T3..	0,105

Reference Referència									Nm
STTC R/L 08CA-09	1222	5506	1404	1503	5015	2804	1804	5025	0.6
STTC R/L 08CA-11	1225	5507	1404	1503	5015	2804	1804	5025	0.9
STTC R/L 10CA-11	1225	5507	1405	1504	5002	2806	1816	5004	0.9
STTC R/L 12CA-16	1240	5515	1405	1505	5025	2806	1806	5004	3.0
STTC R/L 16CA-16	1240	5515	1406	1505	5025	2808	1808	5005	3.0

TC.. Triangular positive inserts with 7° clearance. A44
Plaquetes triangulars positives amb 7° incidència.

Reference / Ref.	l	s	d
TC.. 0902..	9,62	2,38	5,55
TC.. 1102..	11,00	2,38	6,35
TC.. 16T3..	16,50	3,97	9,52

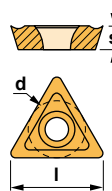

TCGT-AL

TCMT

TCMW





Characteristics:

Cartridge for face turning applications equipped with triangular positive inserts.
 Axial -1,5°
 Radial -2,5°

Característiques:

Cartutx per aplicacions de refrentat equipat amb plaquetes triangulars positives.

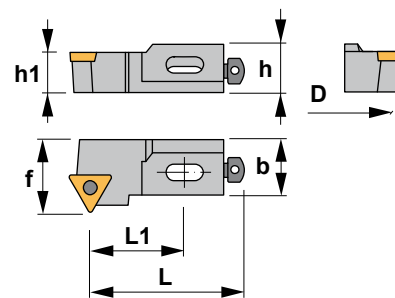

STWC 60°

Reference Referència	D	h	h1	L	L1	f	b	Insert size Mida plaqueta	KG
STWC R/L 08CA-11	25	11	8	27	10	10	7,5	TC.. 1102..	0,005
STWC R/L 10CA-11	30	14	10	44	24	14	10,0	TC.. 1102..	0,035
STWC R/L 12CA-16	40	16	12	47	27	20	14,0	TC.. 16T3..	0,065
STWC R/L 16CA-16	50	20	16	53	28	25	17,5	TC.. 16T3..	0,110

Reference Referència									Nm
STWC R/L 08CA-11	1225	5507	1404	1503	5015	2804	1804	5025	0.9
STWC R/L 10CA-11	1225	5507	1405	1504	5002	2806	1816	5004	0.9
STWC R/L 12CA-16	1240	5515	1405	1505	5025	2806	1806	5004	3.0
STWC R/L 16CA-16	1240	5515	1406	1505	5025	2808	1808	5005	3.0

TC.. Triangular positive inserts with 7° clearance. A44
 Plaquetes triangulars positives amb 7° incidència.

Reference / Ref.	l	s	d
TC.. 1102..	11,00	2,38	6,35
TC.. 16T3..	16,50	3,97	9,52

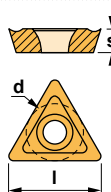

TCGT-AL TCMT TCMW



