



# THREADING ROSCAT



Code system (ISO) Codificació (ISO)	<b>C02</b>
Threading inserts Plaquetes de roscar	<b>C03-10</b>
Applications index Índex d'aplicacions	<b>C11</b>
External threading Roscat exterior	<b>C12-16</b>
Internal threading Roscat interior	<b>C17-20</b>
Cutting data Condicions de tall	<b>C21-24</b>
Technical information Informació tècnica	<b>C25-26</b>

## Code system / Codificació (ISO)

**16** **E** **L** - **AG** **55**

**1** **2** **3** **4** **5**

### 1 Insert size Mida de la plaqueta

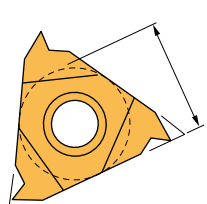

	IC=inch / Polz.	D=mm.
<b>06</b>	5/32	3,96
<b>08</b>	3/16	4,76
<b>11</b>	1/4	6,35
<b>16</b>	3/8	9,52
<b>22</b>	1/2	12,70
<b>27</b>	5/8	15,87

### 2 Insert type Tipus de plaqueta

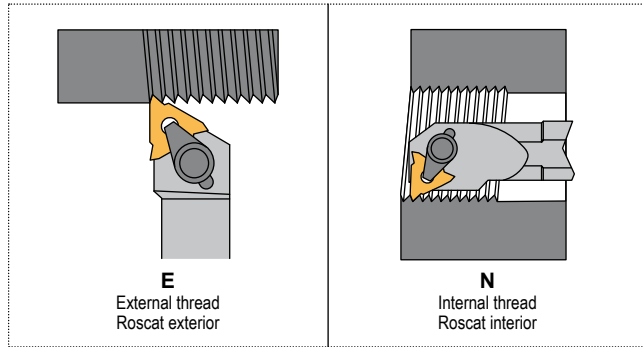

### 3 Hand of insert Direcció de tall de la plaqueta

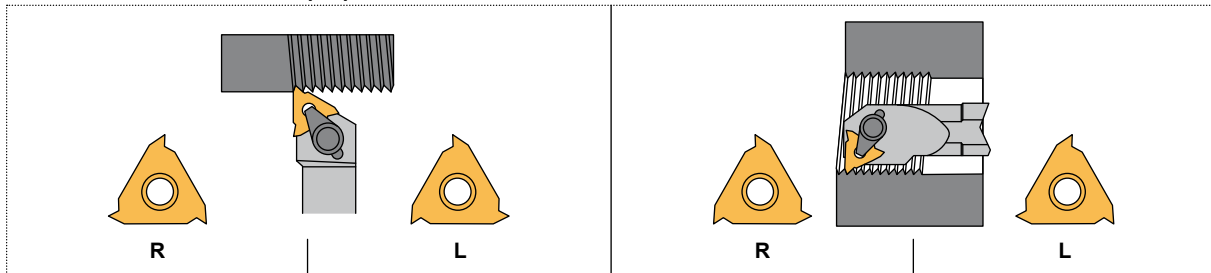

### 4 Pitch Pas

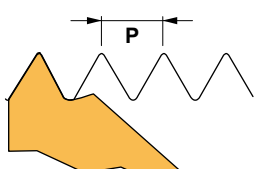

p-mm. x 100  
p-inch / Polzx 10

	mm.	TPI
<b>A</b>	0,5-1,5	48-16
<b>AG</b>	0,5-3,0	48-8
<b>G</b>	1,75-3,0	14-8
<b>N</b>	3,5-5,0	7-5
<b>S</b>	5,5-8,0	4½ - 3½

### 5 Standard Norma

<b>55</b>	Partial profile 55° / Perfil parcial 55°
<b>60</b>	Partial profile 60° / Perfil parcial 60°
<b>ISO</b>	ISO metric / ISO mètric
<b>W</b>	Whitworth, BSW / Whitworth, BSW
<b>LG</b>	Groove type LG / Ranures tipus LG

## Grade characteristics / Característiques de les qualitats

Grades Qualitats	General use / Ús general
<b>TL20</b>	General purpose grade with tough submicron substrate. Provides good fracture toughness in non-rigid cutting conditions. TiAlN coated. Qualitat d'ús general amb un substrat de gra fi. Proporciona una bona resistència al trencament en condicions de tall no rígides. Recoberta TiAlN.
<b>TIN25</b>	General purpose grade, excellent in steel and stainless steel, recommended for rigid cutting conditions. Ground or sintered chipbreaker styles. TiN coated. Qualitat d'ús general, excel·lent per acer i acer inoxidable. Recomanada per condicions de tall rígides. Trencaferritges de tipus rectificat o sinteritzat. Recoberta TiN.



ER



ER TD

### ER-60°

Partial profile thread forms - External inserts 60°-55° (non topping)  
 Plaquetes de rosca exterior 60°-55° (perfil parcial)

Reference / Referència	l	d	p	TIN25	TL20
11ER-A60	11,00	6,35	60°	<input type="radio"/>	<input type="radio"/>
16ER-A60	16,00	9,52	60°	<input type="radio"/>	<input type="radio"/>
16ER-AG60	16,00	9,52	60°	<input checked="" type="radio"/>	<input type="radio"/>
16ER-G60	16,00	9,52	60°	<input checked="" type="radio"/>	<input type="radio"/>
22ER-N60	22,00	12,70	60°	<input checked="" type="radio"/>	<input type="radio"/>
27ER-S60	27,00	15,87	60°	<input type="radio"/>	<input type="radio"/>

### EL-60°

Partial profile thread forms - External inserts 60°-55° (non topping)  
 Plaquetes de rosca exterior 60°-55° (perfil parcial)

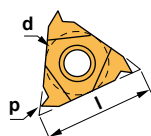

ER

Reference / Referència	l	d	p	TIN25	TL20
11EL-A60	11,00	6,35	60°	<input type="radio"/>	<input type="radio"/>
16EL-A60	16,00	9,52	60°	<input type="radio"/>	<input type="radio"/>
16EL-AG60	16,00	9,52	60°	<input type="radio"/>	<input type="radio"/>
16EL-G60	16,00	9,52	60°	<input type="radio"/>	<input type="radio"/>
22EL-N60	22,00	12,70	60°	<input type="radio"/>	<input type="radio"/>
27EL-S60	27,00	15,87	60°	<input type="radio"/>	<input type="radio"/>

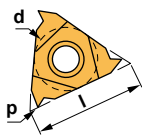

EL

### ER-55°

Partial profile thread forms - External inserts 60°-55° (non topping)  
 Plaquetes de rosca exterior 60°-55° (perfil parcial)

Reference / Referència	l	d	p	TIN25	TL20
11ER-A55	11,00	6,35	55°	<input type="radio"/>	<input type="radio"/>
16ER-A55	16,00	9,52	55°	<input type="radio"/>	<input type="radio"/>
16ER-AG55	16,00	9,52	55°	<input checked="" type="radio"/>	<input type="radio"/>
16ER-G55	16,00	9,52	55°	<input type="radio"/>	<input type="radio"/>
22ER-N55	22,00	12,70	55°	<input type="radio"/>	<input type="radio"/>
27ER-S55	27,00	15,87	55°	<input type="radio"/>	<input type="radio"/>

### EL-55°

Partial profile thread forms - External inserts 60°-55° (non topping)  
 Plaquetes de rosca exterior 60°-55° (perfil parcial)

Reference / Referència	l	d	p	TIN25	TL20
11EL-A55	11,00	6,35	55°	<input type="radio"/>	<input type="radio"/>
16EL-A55	16,00	9,52	55°	<input type="radio"/>	<input type="radio"/>
16EL-AG55	16,00	9,52	55°	<input type="radio"/>	<input type="radio"/>
16EL-G55	16,00	9,52	55°	<input type="radio"/>	<input type="radio"/>
22EL-N55	22,00	12,70	55°	<input type="radio"/>	<input type="radio"/>
27EL-S55	27,00	15,87	55°	<input type="radio"/>	<input type="radio"/>

### ER-55° TD

Partial profile thread forms - External inserts 60°-55° (non topping)  
 Plaquetes de rosca exterior 60°-55° (perfil parcial)

Reference / Referència	l	d	p	TIN25	TL20
16ER-AG55 TD	16,00	9,52	55°	<input checked="" type="radio"/>	<input type="radio"/>





NR

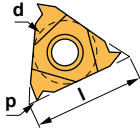

NR

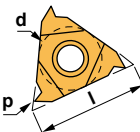

NL



NR-TD

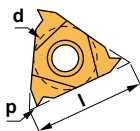

### NR-60°

Partial profile thread forms - Internal inserts 60°-55° (non topping)  
Plaquetes de rosca interiors 60°-55° (perfil parcial)

Reference / Referència	l	d	p	TIN25	TL20
06NR-A60	6,00	3,96	60°	○	○
08NR-A60	8,00	4,76	60°	○	○
11NR-A60	11,00	6,35	60°	●	○
16NR-A60	16,00	9,52	60°	○	○
16NR-AG60	16,00	9,52	60°	●	○
16NR-G60	16,00	9,52	60°	○	○
22NR-N60	22,00	12,70	60°	●	○
27NR-S60	27,00	15,87	60°	○	○

### NL-60°

Partial profile thread forms - Internal inserts 60°-55° (non topping)  
Plaquetes de rosca interiors 60°-55° (perfil parcial)

Reference / Referència	l	d	p	TIN25	TL20
06NL-A60	6,00	3,96	60°	○	○
08NL-A60	8,00	4,76	60°	○	○
11NL-A60	11,00	6,35	60°	○	○
16NL-A60	16,00	9,52	60°	○	○
16NL-AG60	16,00	9,52	60°	○	○
16NL-G60	16,00	9,52	60°	○	○
22NL-N60	22,00	12,70	60°	○	○
27NL-S60	27,00	15,87	60°	○	○

### NR-55°

Partial profile thread forms - Internal inserts 60°-55° (non topping)  
Plaquetes de rosca interiors 60°-55° (perfil parcial)

Reference / Referència	l	d	p	TIN25	TL20
06NR-A55	6,00	3,96	55°	○	○
08NR-A55	8,00	4,76	55°	○	○
11NR-A55	11,00	6,35	55°	○	○
16NR-A55	16,00	9,52	55°	○	○
16NR-AG55	16,00	9,52	55°	●	○
16NR-G55	16,00	9,52	55°	●	○
22NR-N55	22,00	12,70	55°	○	○
27NR-S55	27,00	15,87	55°	○	○

### NL-55°

Partial profile thread forms - Internal inserts 60°-55° (non topping)  
Plaquetes de rosca interiors 60°-55° (perfil parcial)

Reference / Referència	l	d	p	TIN25	TL20
06NL-A55	6,00	3,96	55°	○	○
08NL-A55	8,00	4,76	55°	○	○
11NL-A55	11,00	6,35	55°	○	○
16NL-A55	16,00	9,52	55°	○	○
16NL-AG55	16,00	9,52	55°	○	○
16NL-G55	16,00	9,52	55°	○	○
22NL-N55	22,00	12,70	55°	○	○
27NL-S55	27,00	15,87	55°	○	○

### NR-60° TD

Partial profile thread forms - Internal inserts 60°-55° (non topping)  
Plaquetes de rosca interiors 60°-55° (perfil parcial)

Reference / Referència	l	d	p	TIN25	TL20
16NR-AG60 TD	16,00	9,52	60°	●	○

### NR-55° TD

Partial profile thread forms - Internal inserts 60°-55° (non topping)  
Plaquetes de rosca interiors 60°-55° (perfil parcial)

Reference / Referència	l	d	p	TIN25	TL20
16NR-AG55 TD	16,00	9,52	55°	●	○



ER

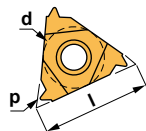

ER

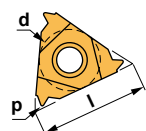

EL

## ER-ISO

Mechanical thread forms - External inserts ISO (full form) BS36  
Plaquetes de rosca exteriors ISO (perfil complet) BS36

Reference / Referència	l	d	p	TIN25	TL20
11ER-030ISO	11,00	6,35	0,30	○	
11ER-040ISO	11,00	6,35	0,40	○	
11ER-045ISO	11,00	6,35	0,45	○	
11ER-050ISO	11,00	6,35	0,50	○	
11ER-060ISO	11,00	6,35	0,60	○	
11ER-070ISO	11,00	6,35	0,70	○	
11ER-075ISO	11,00	6,35	0,75	○	
11ER-080ISO	11,00	6,35	0,80	○	
11ER-100ISO	11,00	6,35	1,00	○	
11ER-125ISO	11,00	6,35	1,25	○	
11ER-150ISO	11,00	6,35	1,50	○	
11ER-175ISO	11,00	6,35	1,75	○	
16ER-075ISO	16,00	9,52	0,75	○	
16ER-100ISO	16,00	9,52	1,00	○	
16ER-125ISO	16,00	9,52	1,25	○	
16ER-150ISO	16,00	9,52	1,50	○	
16ER-175ISO	16,00	9,52	1,75	○	
16ER-200ISO	16,00	9,52	2,00	○	
16ER-250ISO	16,00	9,52	2,50	○	
16ER-300ISO	16,00	9,52	3,00	○	
22ER-350ISO	22,00	12,70	3,50	○	
22ER-400ISO	22,00	12,70	4,00	○	
22ER-450ISO	22,00	12,70	4,50	○	
22ER-500ISO	22,00	12,70	5,00	○	
27ER-500ISO	27,00	15,87	5,00	○	
27ER-550ISO	27,00	15,87	5,50	○	
27ER-600ISO	27,00	15,87	6,00	○	
27ER-800ISO	27,00	15,87	8,00	○	

## EL-ISO

Mechanical thread forms - External inserts ISO (full form) BS36  
Plaquetes de rosca exteriors ISO (perfil complet) BS36

Reference / Referència	l	d	p	TIN25	TL20
16EL-100ISO	16,00	9,52	1,00	○	
16EL-125ISO	16,00	9,52	1,25	○	
16EL-150ISO	16,00	9,52	1,50	○	
16EL-175ISO	16,00	9,52	1,75	○	
16EL-200ISO	16,00	9,52	2,00	○	
16EL-250ISO	16,00	9,52	2,50	○	
16EL-300ISO	16,00	9,52	3,00	○	
22EL-400ISO	22,00	12,70	4,00	○	



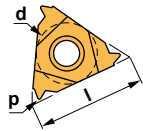

## NR-ISO

Mechanical thread forms - Internal inserts ISO (full form) BS36  
Plaquetes de roscar interiors ISO (perfil complet) BS36

Reference / Referència	l	d	p	TIN25	TL20
06NR-050ISO	6,00	3,96	0,50	○	
06NR-075ISO	6,00	3,96	0,75	○	
06NR-100ISO	6,00	3,96	1,00	○	
06NR-125ISO	6,00	3,96	1,25	○	
08NR-050ISO	8,00	4,76	0,50	○	
08NR-075ISO	8,00	4,76	0,75	○	
08NR-100ISO	8,00	4,76	1,00	○	
08NR-125ISO	8,00	4,76	1,25	○	
08NR-150ISO	8,00	4,76	1,50	○	
08NR-175ISO	8,00	4,76	1,75	○	
11NR-035ISO	11,00	6,35	0,35	○	
11NR-040ISO	11,00	6,35	0,40	○	
11NR-045ISO	11,00	6,35	0,45	○	
11NR-050ISO	11,00	6,35	0,50	○	
11NR-060ISO	11,00	6,35	0,60	○	
11NR-070ISO	11,00	6,35	0,70	○	
11NR-075ISO	11,00	6,35	0,75	○	
11NR-080ISO	11,00	6,35	0,80	○	
11NR-100ISO	11,00	6,35	1,00	○	
11NR-125ISO	11,00	6,35	1,25	○	
11NR-150ISO	11,00	6,35	1,50	○	
11NR-175ISO	11,00	6,35	1,75	○	
11NR-200ISO	11,00	6,35	2,00	○	
11NR-250ISO	11,00	6,35	2,50	○	
16NR-075ISO	16,00	9,52	0,75	○	
16NR-100ISO	16,00	9,52	1,00	○	
16NR-125ISO	16,00	9,52	1,25	○	
16NR-150ISO	16,00	9,52	1,50	○	
16NR-175ISO	16,00	9,52	1,75	○	
16NR-200ISO	16,00	9,52	2,00	○	
16NR-250ISO	16,00	9,52	2,50	○	
16NR-300ISO	16,00	9,52	3,00	○	
22NR-350ISO	22,00	12,70	3,50	○	
22NR-400ISO	22,00	12,70	4,00	○	
22NR-450ISO	22,00	12,70	4,50	○	
22NR-500ISO	22,00	12,70	5,00	○	
27NR-500ISO	27,00	15,87	5,00	○	
27NR-550ISO	27,00	15,87	5,50	○	
27NR-600ISO	27,00	15,87	6,00	○	
27NR-800ISO	27,00	15,87	8,00	○	



NL ISO

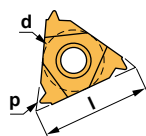

NL

## NL-ISO

Mechanical thread forms - Internal inserts ISO (full form) BS36  
Plaquetes de roscar interiors ISO (perfil complet) BS36

Reference / Referència	l	d	p	TIN25	TL20
06NL-050ISO	6,00	3,96	0,50	○	
06NL-075ISO	6,00	3,96	0,75	○	
06NL-100ISO	6,00	3,96	1,00	○	
06NL-125ISO	6,00	3,96	1,25	○	
08NL-050ISO	8,00	4,76	0,50	○	
08NL-075ISO	8,00	4,76	0,75	○	
08NL-100ISO	8,00	4,76	1,00	○	
08NL-125ISO	8,00	4,76	1,25	○	
08NL-150ISO	8,00	4,76	1,50	○	
08NL-175ISO	8,00	4,76	1,75	○	
11NL-100ISO	11,00	6,35	1,00	○	
11NL-150ISO	11,00	6,35	1,50	○	
16NL-100ISO	16,00	9,52	1,00	○	
16NL-125ISO	16,00	9,52	1,25	○	
16NL-150ISO	16,00	9,52	1,50	○	
16NL-175ISO	16,00	9,52	1,75	○	
16NL-200ISO	16,00	9,52	2,00	○	
16NL-250ISO	16,00	9,52	2,50	○	
16NL-300ISO	16,00	9,52	3,00	○	
22NL-400ISO	22,00	12,70	4,00	○	



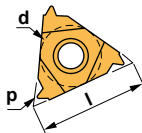

ER

### ER-W

Mechanical thread forms - External and internal inserts **WHITWORTH (full form) BS84**  
Plaquetes de rosca exteriors i interiors **WHITWORTH (perfil complet) BS84**

Reference / Referència	l	d	p	TIN25	TL20
11ER-14W	11,00	6,35	14,0	○	
11ER-16W	11,00	6,35	16,0	○	
11ER-18W	11,00	6,35	18,0	○	
11ER-19W	11,00	6,35	19,0	○	
11ER-22W	11,00	6,35	22,0	○	
11ER-24W	11,00	6,35	24,0	○	
11ER-26W	11,00	6,35	26,0	○	
11ER-28W	11,00	6,35	28,0	○	
11ER-40W	11,00	6,35	40,0	○	
11ER-50W	11,00	6,35	50,0	○	
11ER-56W	11,00	6,35	56,0	○	
16ER-8W	16,00	9,52	8,0	○	
16ER-9W	16,00	9,52	9,0	○	
16ER-10W	16,00	9,52	10,0	○	
16ER-11W	16,00	9,52	11,0	○	
16ER-12W	16,00	9,52	12,0	○	
16ER-14W	16,00	9,52	14,0	○	
16ER-16W	16,00	9,52	16,0	○	
16ER-18W	16,00	9,52	18,0	○	
16ER-19W	16,00	9,52	19,0	○	
16ER-20W	16,00	9,52	20,0	○	
16ER-22W	16,00	9,52	22,0	○	
16ER-24W	16,00	9,52	24,0	○	
16ER-26W	16,00	9,52	26,0	○	
16ER-28W	16,00	9,52	28,0	○	
22ER-4W	22,00	12,70	4,0	○	
22ER-4.5W	22,00	12,70	4,5	○	
22ER-5W	22,00	12,70	5,0	○	
22ER-6W	22,00	12,70	6,0	○	
22ER-7W	22,00	12,70	7,0	○	
22ER-8W	22,00	12,70	8,0	○	
27ER-4W	27,00	15,87	4,0	○	
27ER-4.5W	27,00	15,87	4,5	○	



EL-W

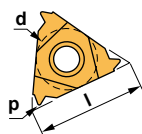

EL

### EL-W

Mechanical thread forms - External and internal inserts **WHITWORTH (full form) BS84**  
Plaquetes de rosca exteriors i interiors **WHITWORTH (perfil complet) BS84**

Reference / Referència	l	d	p	TIN25	TL20
16EL-11W	16,00	9,52	11,0	○	
16EL-14W	16,00	9,52	14,0	○	
16EL-20W	16,00	9,52	20,0	○	



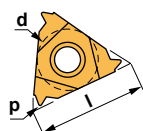

NR

## NR-W

Mechanical thread forms - Internal inserts **WHITWORTH (full form) BS84**  
 Plaquetes de roscar interiors **WHITWORTH (perfil complet) BS84**

Reference / Referència	l	d	p	TIN25	TL20
06NR-18W	6,00	3,96	18,0	○	○
06NR-19W	6,00	3,96	19,0	○	○
06NR-20W	6,00	3,96	20,0	○	○
06NR-22W	6,00	3,96	22,0	○	○
06NR-26W	6,00	3,96	26,0	○	○
08NR-16W	8,00	4,76	16,0	○	○
08NR-18W	8,00	4,76	18,0	○	○
08NR-19W	8,00	4,76	19,0	○	○
08NR-20W	8,00	4,76	20,0	○	○
08NR-24W	8,00	4,76	24,0	○	○
08NR-28W	8,00	4,76	28,0	○	○
11NR-11W	11,00	6,35	11,0	○	○
11NR-12W	11,00	6,35	12,0	○	○
11NR-14W	11,00	6,35	14,0	○	○
11NR-16W	11,00	6,35	16,0	○	○
11NR-18W	11,00	6,35	18,0	○	○
11NR-19W	11,00	6,35	19,0	○	○
11NR-20W	11,00	6,35	20,0	○	○
11NR-22W	11,00	6,35	22,0	○	○
11NR-24W	11,00	6,35	24,0	○	○
11NR-26W	11,00	6,35	26,0	○	○
11NR-28W	11,00	6,35	28,0	○	○
11NR-32W	11,00	6,35	32,0	○	○
11NR-36W	11,00	6,35	36,0	○	○
11NR-40W	11,00	6,35	40,0	○	○
11NR-48W	11,00	6,35	48,0	○	○
16NR-8W	16,00	9,52	8,0	○	○
16NR-9W	16,00	9,52	9,0	○	○
16NR-10W	16,00	9,52	10,0	○	○
16NR-11W	16,00	9,52	11,0	○	○
16NR-12W	16,00	9,52	12,0	○	○
16NR-14W	16,00	9,52	14,0	○	○
16NR-16W	16,00	9,52	16,0	○	○
16NR-18W	16,00	9,52	18,0	○	○
16NR-19W	16,00	9,52	19,0	○	○
16NR-20W	16,00	9,52	20,0	○	○
16NR-22W	16,00	9,52	22,0	○	○
16NR-24W	16,00	9,52	24,0	○	○
16NR-26W	16,00	9,52	26,0	○	○
16NR-28W	16,00	9,52	28,0	○	○
22NR-4W	22,00	12,70	4,0	○	○
22NR-4.5W	22,00	12,70	4,5	○	○
22NR-5W	22,00	12,70	5,0	○	○
22NR-6W	22,00	12,70	6,0	○	○
22NR-7W	22,00	12,70	7,0	○	○





NL-W

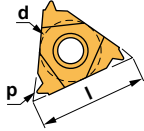

NL

### NL-W

Mechanical thread forms - Internal inserts WHITWORTH (full form) BS84  
Plaquetes de roscar interiors WHITWORTH (perfil complet) BS84

Reference / Referència	l	d	p	TIN25	TL20
06NL-18W	6,00	3,96	18,0	○	○
06NL-20W	6,00	3,96	20,0	○	○
06NL-22W	6,00	3,96	22,0	○	○
06NL-26W	6,00	3,96	26,0	○	○
08NL-16W	8,00	4,76	16,0	○	○
08NL-18W	8,00	4,76	18,0	○	○
08NL-19W	8,00	4,76	19,0	○	○
08NL-20W	8,00	4,76	20,0	○	○
08NL-24W	8,00	4,76	24,0	○	○
08NL-28W	8,00	4,76	28,0	○	○
16NL-11W	16,00	9,52	11,0	○	○
16NL-14W	16,00	9,52	14,0	○	○
16NL-16W	16,00	9,52	16,0	○	○



ER-LG

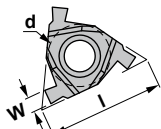

ER

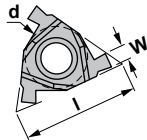

EL

### ER-LG

External lock ring grooving inserts - Type LG  
Plaquetes de ranurat exterior per anells de seguretat tipus LG

Reference / Referència	l	d	W	TIN25	TL20
16ER-100LG	16,00	9,52	1,15	●	●
16ER-120LG	16,00	9,52	1,35	●	●
16ER-150LG	16,00	9,52	1,65	●	●
16ER-175LG	16,00	9,52	1,90	●	●
16ER-200LG	16,00	9,52	2,15	●	●
16ER-250LG	16,00	9,52	2,65	●	●

### EL-LG

External lock ring grooving inserts - Type LG  
Plaquetes de ranurat exterior per anells de seguretat tipus LG

Reference / Referència	l	d	W	TIN25	TL20
16EL-100LG	16,00	9,52	1,15	●	●
16EL-120LG	16,00	9,52	1,35	●	●
16EL-150LG	16,00	9,52	1,65	●	●
16EL-175LG	16,00	9,52	1,90	●	●
16EL-200LG	16,00	9,52	2,15	●	●

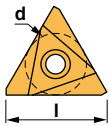

### TNMC

Triangular negative insert for threading.  
Plaqueta triangular negativa per roscar.

Reference / Referència	l	s	d	PM25	TN15
TNMC 1603XX	16,50	3,18	9,52	○	○
TNMC 2204XX	22,00	4,76	12,70	●	○

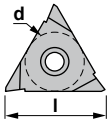

### TPMC

Triangular positive insert for threading.  
Plaqueta triangular positiva per roscar.

Reference / Referència	l	s	d	PM25	TN15
TPMC 1603XX	16,50	3,18	9,52	○	○
TPMC 2204XX	22,00	4,76	12,70	○	○

## External threading Roscat exterior

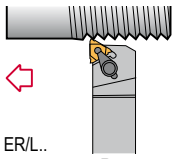
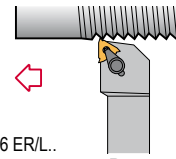
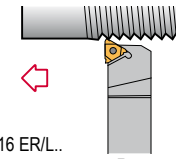
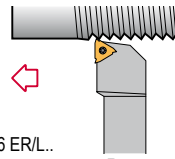
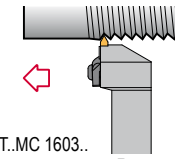
<p><b>CTAN 90°</b></p>  <p>16 ER/L... 22 ER/L... 27 ER/L...</p> <p>Page Pàgina C12</p>	<p><b>CTXN 90°</b></p>  <p>16 ER/L... 22 ER/L... 27 ER/L...</p> <p>Page Pàgina C13</p>	<p><b>STAN 90°</b></p>  <p>16 ER/L... 22 ER/L... 27 ER/L...</p> <p>Page Pàgina C14</p>	<p><b>STXN 90°</b></p>  <p>16 ER/L... 22 ER/L... 27 ER/L...</p> <p>Page Pàgina C15</p>	<p><b>STCN 90°</b></p>  <p>T..MC 1603.. T..MC 2204.. T..MC 2706..</p> <p>Page Pàgina C16</p>
---	---	---	--	---

## Internal threading Roscat interior

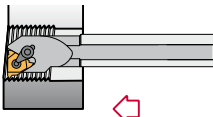
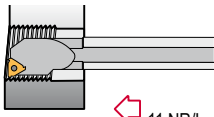
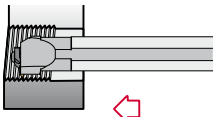
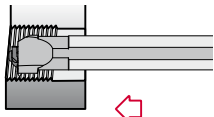
<p><b>CTXN 90°</b></p>  <p>Page Pàgina C17</p> <p>16 NR/L... 22 NR/L... 27 NR/L...</p>	<p><b>STXN 90°</b></p>  <p>Page Pàgina C18</p> <p>11 NR/L... 16 NR/L... 22 NR/L... 27 NR/L...</p>	<p><b>STGN 90°</b></p>  <p>Page Pàgina C19</p> <p>TNMC 1603.. TNMC 2204.. TNMC 2706..</p>	<p><b>STGP 90°</b></p>  <p>Page Pàgina C20</p> <p>TPMC 1603.. TPMC 2204..</p>	
---	--	--	---	--





**Characteristics:**  
Multipurpose top clamp threading toolholder for negative lay down inserts.

**Característiques:**  
Portaeines de roscat multifunció per plaquetes negatives amb fixació per brida.

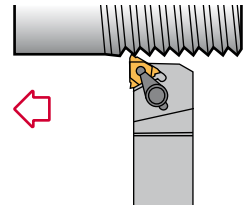
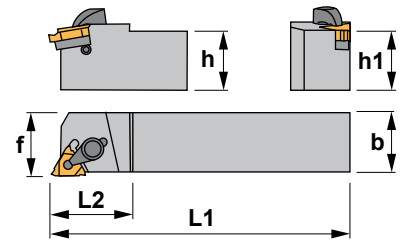

## CTAN 90°

Reference Referència	h=h1	b	L1	L2	f	Insert size Mida plaqueta	Kg
CTAN R/L 2020 K16	20	20	125	28	20	16 ER/L..	0,400
CTAN R/L 2525 M16	25	25	150	28	25	16 ER/L..	0,700
CTAN R/L 3232 P16	32	32	170	28	32	16 ER/L..	1,050
CTAN R/L 2525 M22	25	25	150	34	25	22 ER/L..	0,700
CTAN R/L 3232 P22	32	32	170	34	32	22 ER/L..	1,300
CTAN R/L 4040 R22	40	40	200	36	40	22 ER/L..	3,000
CTAN R/L 3232 P27	32	32	170	34	32	27 ER/L..	1,300
CTAN R/L 4040 R27	40	40	200	40	40	27 ER/L..	3,000
CTAN R/L 5050 S27	50	50	250	40	50	27 ER/L..	5,800

**WARNING!!** Because of large thread profile, modification may have to be made to the toolholder to achieve full depth of thread.  
**ATENCIÓ!!** És possible que hàgiu de modificar l'eina per aconseguir la profunditat total de la rosca, en cas que el perfil de la rosca sigui massa gran.

Reference Referència								Nm
CTAN R/L 2020 K16	2516	5515	5510	YE3	YI3	SY3	SA3	2.0
CTAN R/L 2525 M16	2516	5515	5510	YE3	YI3	SY3	SA3	2.0
CTAN R/L 3232 P16	2516	5515	-	YE3	YI3	SY3	SA3	-
CTAN R/L 2525 M22	2522	5515	5520	YE4	YI4	SY4	SA4	4.0
CTAN R/L 3232 P22	2522	5515	5520	YE4	YI4	SY4	SA4	4.0
CTAN R/L 4040 R22	2522	5515	5520	YE4	YI4	SY4	SA4	4.0
CTAN R/L 3232 P27	2527	5525	-	YE5	YI5	SY5	SA5	-
CTAN R/L 4040 R27	2527	5525	-	YE5	YI5	SY5	SA5	-
CTAN R/L 5050 S27	2527	5525	-	YE5	YI5	SY5	SA5	-

Optional  
Opcional

### E R/L

Triangular negative inserts for external threading.  
Plaquetes triangulars negatives per roscat exterior. C03,05,08,10

Reference / Ref.	l	d
16 ER/L..	16,00	9,52
22 ER/L..	22,00	12,70
27 ER/L..	27,50	15,88

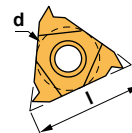

E R/L	E R/L TD
<b>ER/L-LG</b>	



**Characteristics:**  
Multipurpose top clamp threading toolholder for negative lay down inserts.

**Característiques:**  
Portaeines de roscat multifunció per plaquetes negatives amb fixació per brida.

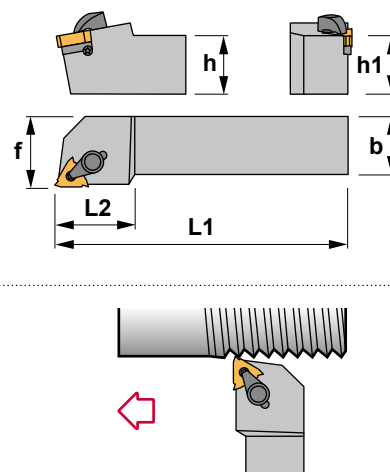

## CTXN 90°

Reference Referència	h=h1	b	L1	L2	f	Insert size Mida plaqueta	kg
CTXN R/L 1212 F16	12	12	80	25	16	16 ER/L..	0,100
CTXN R/L 1616 H16	16	16	100	25	20	16 ER/L..	0,200
CTXN R/L 2020 K16	20	20	125	28	25	16 ER/L..	0,400
CTXN R/L 2525 M16	25	25	150	28	32	16 ER/L..	0,700
CTXN R/L 3232 P16	32	32	170	28	40	16 ER/L..	1,050
CTXN R/L 2525 M22	25	25	150	34	32	22 ER/L..	0,700
CTXN R/L 3232 P22	32	32	170	34	40	22 ER/L..	1,300
CTXN R/L 4040 R22	40	40	200	36	50	22 ER/L..	3,000
CTXN R/L 2525 M27	25	25	150	34	32	27 ER/L..	0,700
CTXN R/L 3232 P27	32	32	170	34	40	27 ER/L..	1,300
CTXN R/L 4040 R27	40	40	200	40	50	27 ER/L..	3,000
CTXN R/L 5050 S27	50	50	250	50	60	27 ER/L..	5,800

**WARNING!!** Because of large thread profile, modification may have to be made to the toolholder to achieve full depth of thread.  
**ATENCIÓ!!** És possible que hàgiu de modificar l'eina per aconseguir la profunditat total de la rosca, en cas que el perfil de la rosca sigui massa gran.

Reference Referència							Nm
CTXN R/L 1212 F16	2516	5515	YE3	YI3	SY3	SA3	3.0
CTXN R/L 1616 H16	2516	5515	YE3	YI3	SY3	SA3	3.0
CTXN R/L 2020 K16	2516	5515	YE3	YI3	SY3	SA3	3.0
CTXN R/L 2525 M16	2516	5515	YE3	YI3	SY3	SA3	3.0
CTXN R/L 3232 P16	2516	5515	YE3	YI3	SY3	SA3	3.0
CTXN R/L 2525 M22	2522	5515	YE4	YI4	SY4	SA4	3.0
CTXN R/L 3232 P22	2522	5515	YE4	YI4	SY4	SA4	3.0
CTXN R/L 4040 R22	2522	5515	YE4	YI4	SY4	SA4	3.0
CTXN R/L 2525 M27	2527	5525	YE5	YI5	SY5	SA5	5.0
CTXN R/L 3232 P27	2527	5525	YE5	YI5	SY5	SA5	5.0
CTXN R/L 4040 R27	2527	5525	YE5	YI5	SY5	SA5	5.0
CTXN R/L 5050 S27	2527	5525	YE5	YI5	SY5	SA5	5.0

Optional  
Opcional

### E R/L

Triangular negative inserts for external threading.  
Plaquetes triangulars negatives per roscat exterior. ⓘ C03,05,08,10

Reference / Ref.	l	d
16 ER/L..	16,00	9,52
22 ER/L..	22,00	12,70
27 ER/L..	27,50	15,88

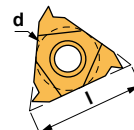

E R/L	E R/L TD
<b>ER/L-LG</b>	



**Characteristics:**  
Multipurpose threading toolholder for negative lay down inserts.

**Característiques:**  
Portaeines de roscat multifunció amb plaquetes negatives.

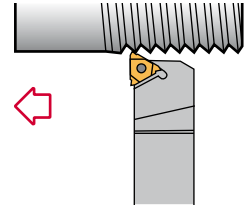
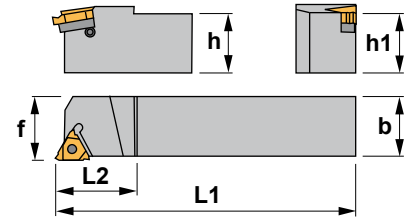

## STAN 90°

Reference Referència	h=h1	b	L1	L2	f	Insert size Mida plaqueta	 kg
STAN R/L 1616 H16	16	16	100	22	16	16 ER/L..	0,070
STAN R/L 2020 K16	20	20	125	28	20	16 ER/L..	0,100
STAN R/L 2525 M16	25	25	150	28	25	16 ER/L..	0,140
STAN R/L 3232 P16	32	32	170	28	32	16 ER/L..	0,200
STAN R/L 2525 M22	25	25	150	34	25	22 ER/L..	0,270
STAN R/L 3232 P22	32	32	175	34	32	22 ER/L..	0,400
STAN R/L 4040 R22	40	40	200	34	40	22 ER/L..	0,700
STAN R/L 3232 P27	32	32	170	34	32	27 ER/L..	1,300
STAN R/L 4040 R27	40	40	200	34	40	27 ER/L..	0,700
STAN R/L 5050 S27	50	50	250	34	50	27 ER/L..	1,300

**WARNING!!** Because of large thread profile, modification may have to be made to the toolholder to achieve full depth of thread.  
**ATENCIÓ!!** És possible que hàgiu de modificar l'eina per aconseguir la profunditat total de la rosca, en cas que el perfil de la rosca sigui massa gran.

Reference Referència						Nm
STAN R/L 1616 H16	SA3	5510	YE3	YI3	SY3	2.0
STAN R/L 2020 K16	SA3	5510	YE3	YI3	SY3	2.0
STAN R/L 2525 M16	SA3	5510	YE3	YI3	SY3	2.0
STAN R/L 3232 P16	SA3	5510	YE3	YI3	SY3	2.0
STAN R/L 2525 M22	SA4	5520	YE4	YI4	SY4	4.0
STAN R/L 3232 P22	SA4	5520	YE4	YI4	SY4	4.0
STAN R/L 4040 R22	SA4	5520	YE4	YI4	SY4	4.0
STAN R/L 3232 P27	SA5	5525	YE5	YI5	SY5	5.0
STAN R/L 4040 R27	SA5	5525	YE5	YI5	SY5	5.0
STAN R/L 5050 S27	SA5	5525	YE5	YI5	SY5	5.0

### E R/L

Triangular negative inserts for external threading.  
Plaquetes triangulars negatives per roscat exterior.  C03,05,08,10

Reference / Ref.	l	d
16 ER/L..	16,00	9,52
22 ER/L..	22,00	12,70
27 ER/L..	27,50	15,88

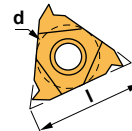



**Characteristics:**  
Multipurpose threading toolholder for negative lay down inserts.



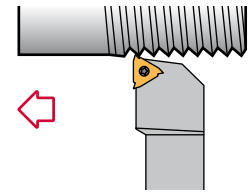
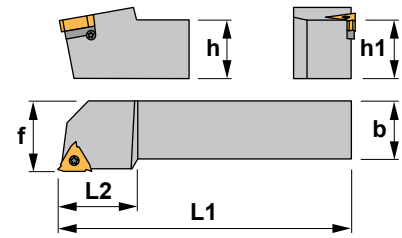

**Característiques:**  
Portaeines de rosca multifunció amb plaquetes negatives.



## STXN 90°

Reference Referència	h=h1	b	L1	L2	f	Insert size Mida plaqueta	
STXN R/L 1212 F16	12	12	80	25	16	16 ER/L..	0,100
STXN R/L 1616 H16	16	16	100	25	20	16 ER/L..	0,200
STXN R/L 2020 K16	20	20	125	28	25	16 ER/L..	0,400
STXN R/L 2525 M16	25	25	150	28	32	16 ER/L..	0,700
STXN R/L 3232 P16	32	32	170	28	40	16 ER/L..	1,050
STXN R/L 2525 M22	25	25	150	34	32	22 ER/L..	0,700
STXN R/L 3232 P22	32	32	170	34	40	22 ER/L..	1,300
STXN R/L 4040 R22	40	40	200	34	50	22 ER/L..	3,000
STXN R/L 2525 M27	25	25	150	34	32	27 ER/L..	0,700
STXN R/L 3232 P27	32	32	170	34	40	27 ER/L..	1,300
STXN R/L 4040 R27	40	40	200	34	50	27 ER/L..	3,000
STXN R/L 5050 S27	50	50	250	34	60	27 ER/L..	5,800

**WARNING!!** Because of large thread profile, modification may have to be made to the toolholder to achieve full depth of thread.  
**ATENCIÓ!!** És possible que hàgiu de modificar l'eina per aconseguir la profunditat total de la rosca, en cas que el perfil de la rosca sigui massa gran.

Reference Referència						Nm
STXN R/L 1212 F16	SA3T	5510	YE3	YI3	SY3	2.0
STXN R/L 1616 H16	SA3	5510	YE3	YI3	SY3	2.0
STXN R/L 2020 K16	SA3	5510	YE3	YI3	SY3	2.0
STXN R/L 2525 M16	SA3	5510	YE3	YI3	SY3	2.0
STXN R/L 3232 P16	SA3	5510	YE3	YI3	SY3	2.0
STXN R/L 2525 M22	SA4	5520	YE4	YI4	SY4	4.0
STXN R/L 3232 P22	SA4	5520	YE4	YI4	SY4	4.0
STXN R/L 4040 R22	SA4	5520	YE4	YI4	SY4	4.0
STXN R/L 2525 M27	SA5	5525	YE5	YI5	SY5	5.0
STXN R/L 3232 P27	SA5	5525	YE5	YI5	SY5	5.0
STXN R/L 4040 R27	SA5	5525	YE5	YI5	SY5	5.0
STXN R/L 5050 S27	SA5	5525	YE5	YI5	SY5	5.0

### E R/L

Triangular negative inserts for external threading.  
Plaquetes triangulars negatives per rosca exterior.  C03,05,08,10

Reference / Ref.	l	d
16 ER/L..	16,00	9,52
22 ER/L..	22,00	12,70
27 ER/L..	27,50	15,88

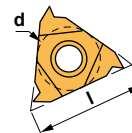

E R/L	E R/L TD
	
	







Characteristics:  
Vertical on edge threading toolholder.

Característiques:  
Portaeines de roscat exterior vertical a l'aresta.

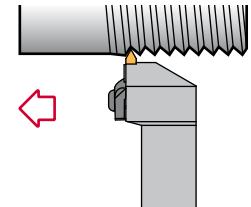
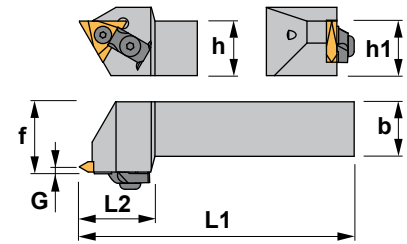

## STCN 90°

Reference Referència	h=h1	b	L1	L2	f	G	Insert size Mida plaqueta	⚖️ Kg
STCN R/L 1212 F16	12	12	80	25	16	1,59	TNMC/TPMC 1603..	0,100
STCN R/L 1616 H16	16	16	100	25	19	1,59	TNMC/TPMC 1603..	0,200
STCN R/L 2020 K16	20	20	125	28	22	1,59	TNMC/TPMC 1603..	0,400
STCN R/L 2525 M16	25	25	150	34	32	1,59	TNMC/TPMC 1603..	0,700
STCN R/L 3232 P16	32	32	170	34	38	1,59	TNMC/TPMC 1603..	1,050
STCN R/L 2020 K22	20	20	125	34	22	2,38	TNMC/TPMC 2204..	0,400
STCN R/L 2525 M22	25	25	150	34	32	2,38	TNMC/TPMC 2204..	0,700
STCN R/L 3225 P22	32	25	170	34	32	2,38	TNMC/TPMC 2204..	1,025
STCN R/L 3232 P22	32	32	170	34	38	2,38	TNMC/TPMC 2204..	1,050
STCN R/L 2525 M27	25	25	150	38	32	2,38	TNMC/TPMC 2706..	0,700
STCN R/L 3232 P27	32	32	170	42	38	2,38	TNMC/TPMC 2706..	1,050

Reference Referència					1	2	Nm <sup>1</sup>	Nm <sup>2</sup>
STCN R/L 1212 F16	1935	-	-	-	-	-	-	-
STCN R/L 1616 H16	1935	-	-	-	-	-	-	-
STCN R/L 2020 K16	1935	2101	1815	5003	5002	3.0	1.4	
STCN R/L 2525 M16	1935	2101	1815	5003	5002	3.0	1.4	
STCN R/L 3232 P16	1935	2101	1815	5003	5002	3.0	1.4	
STCN R/L 2020 K22	1950	2101	1815	5003	5025	3.0	2.0	
STCN R/L 2525 M22	1950	2101	1815	5003	5025	3.0	2.0	
STCN R/L 3225 P22	1950	2101	1815	5003	5025	3.0	2.0	
STCN R/L 3232 P22	1950	2101	1815	5003	5025	3.0	2.0	
STCN R/L 2525 M27	1955	2101	1815	-	5003	3.0	3.0	
STCN R/L 3232 P27	1955	2101	1815	-	5003	3.0	3.0	

### TNMC/TPMC

Triangular negative and positive inserts for external threading. C10  
Plaquetes triangulars negatives i positives per roscat exterior.

Reference / Ref.	l	s	d
T..MC 1603..	16,50	3,18	9,52
T..MC 2204..	22,00	4,76	12,70
T..MC 2706..	27,00	6,35	15,88

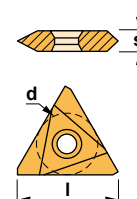





**Characteristics:**

Multipurpose top clamp threading boring bar for negative lay down inserts.

**Característiques:**

Barra de mandrinar de roscat multifunció per plaquetes negatives amb fixació per brida.

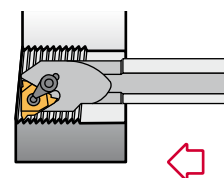
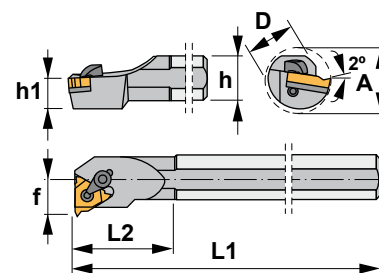

## CTXN 90°

Reference Referència	D	h	h1	L1	L2	f	A	Insert size Mida plaqueta	⚠ Kg
S20Q CTXN R/L 16	20	18	9,0	180	35	13,0	24	16 NR/L..	0,400
S25R CTXN R/L 16	25	23	11,5	200	40	17,0	29	16 NR/L..	0,700
S32S CTXN R/L 16	32	30	15,0	250	45	22,0	36	16 NR/L..	1,500
S40T CTXN R/L 16	40	37	18,5	300	50	27,0	44	16 NR/L..	2,850
S25R CTXN R/L 22	25	23	11,5	200	40	17,0	32	22 NR/L..	0,700
S32S CTXN R/L 22	32	30	15,0	250	45	22,0	39	22 NR/L..	1,500
S40T CTXN R/L 22	40	37	18,5	300	50	27,0	47	22 NR/L..	2,850
S32S CTXN R/L 27	32	30	15,0	250	45	22,4	40	27 NR/L..	1,500
S40T CTXN R/L 27	40	37	18,5	300	50	26,4	48	27 NR/L..	2,850
S50U CTXN R/L 27	50	47	23,5	350	60	31,4	58	27 NR/L..	5,200
S60V CTXN R/L 27	60	58	29,0	400	60	36,4	69	27 NR/L..	8,550

**WARNING!!** Because of large thread profile, modification may have to be made to the boring bar to achieve full depth of thread.  
**ATENCIÓ!!** És possible que hàgiu de modificar la barra de mandrinar per aconseguir la profunditat total de la rosca, en cas que el perfil de la rosca sigui massa gran.

Reference Referència							Nm
S20Q CTXN R/L 16	2516	5515	YI3	YE3	SY3	SN3	3.0
S25R CTXN R/L 16	2516	5515	YI3	YE3	SY3	SA3	3.0
S32S CTXN R/L 16	2516	5515	YI3	YE3	SY3	SA3	3.0
S40T CTXN R/L 16	2516	5515	YI3	YE3	SY3	SA3	3.0
S25R CTXN R/L 22	2522	5515	YI4	YE4	SY4	SA4	3.0
S32S CTXN R/L 22	2522	5515	YI4	YE4	SY4	SA4	3.0
S40T CTXN R/L 22	2522	5515	YI4	YE4	SY4	SA4	3.0
S32S CTXN R/L 27	2527	5525	YI5	YE5	SY5	SA5	5.0
S40T CTXN R/L 27	2527	5525	YI5	YE5	SY5	SA5	5.0
S50U CTXN R/L 27	2527	5525	YI5	YE5	SY5	SA5	5.0
S60V CTXN R/L 27	2527	5525	YI5	YE5	SY5	SA5	5.0

Optional  
Opcional

### N R/L

Triangular negative inserts for internal threading. Plaquetes triangulars negatives de roscat interior. ⓘ C04,06,07,09,10

Reference / Ref.	l	d
16 NR/L..	16,00	9,52
22 NR/L..	22,00	12,70
27 NR/L..	27,00	15,87

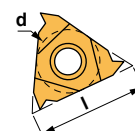

### N R/L



### N R/L TD





**Characteristics:**  
Multipurpose threading boring bar for negative lay down inserts.

**Característiques:**  
Barra de mandrinar de roscat multifunció per plaquetes negatives.

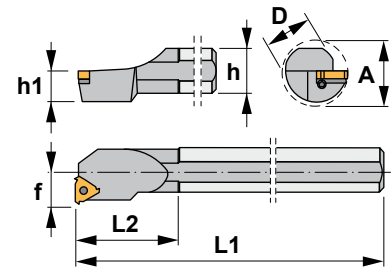
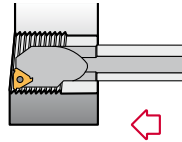

## STXN 90°

Reference Referència	D	h	h1	L1	L2	f	A	Insert size Mida plaqueta	⚖️ KG
S10K STXN R/L 11	10	9	4,5	125	16	7,3	13	11 NR/L..	0,070
S16M STXN R/L 11	16	15	7,5	150	25	8,9	16	11 NR/L..	0,200
S16M STXN R/L 16	16	15	7,5	150	30	11,5	20	16 NR/L..	0,200
S20Q STXN R/L 16	20	18	9,0	180	35	13,4	24	16 NR/L..	0,400
S25R STXN R/L 16	25	23	11,5	200	40	16,3	29	16 NR/L..	0,700
S32S STXN R/L 16	32	30	15,0	250	45	19,6	36	16 NR/L..	1,500
S40T STXN R/L 16	40	37	18,5	300	50	23,8	44	16 NR/L..	2,850
S20Q STXN R/L 22	20	18	9,0	180	35	15,6	27	22 NR/L..	0,400
S25R STXN R/L 22	25	23	11,5	200	40	17,2	32	22 NR/L..	0,700
S32S STXN R/L 22	32	30	15,0	250	45	21,5	39	22 NR/L..	1,500
S40T STXN R/L 22	40	37	18,5	300	50	25,8	47	22 NR/L..	2,850
S32S STXN R/L 27	32	30	15,0	250	45	22,4	40	27 NR/L..	1,500
S40T STXN R/L 27	40	37	18,5	300	50	26,4	48	27 NR/L..	2,850
S50U STXN R/L 27	50	47	23,5	350	60	31,4	58	27 NR/L..	5,200
S60V STXN R/L 27	60	57	28,5	400	60	36,4	69	27 NR/L..	8,550

**WARNING!!** Because of large thread profile, modification may have to be made to the boring bar to achieve full depth of thread.  
**ATENCIÓ!!** És possible que hàgiu de modificar la barra de mandrinar per aconseguir la profunditat total de la rosca, en cas que el perfil de la rosca sigui massa gran.

Reference Referència						Nm
S10K STXN R/L 11	1225	5507	-	-	-	0.9
S16M STXN R/L 11	1225	5507	-	-	-	0.9
S16M STXN R/L 16	SN3	5510	-	-	-	2.0
S20Q STXN R/L 16	SA3T	5510	YI3	YE3	SY3	2.0
S25R STXN R/L 16	SA3	5510	YI3	YE3	SY3	2.0
S32S STXN R/L 16	SA3	5510	YI3	YE3	SY3	2.0
S40T STXN R/L 16	SA3	5510	YI3	YE3	SY3	2.0
S20Q STXN R/L 22	SN4	5520	-	-	-	4.0
S25R STXN R/L 22	SA4	5520	YI4	YE4	SY4	4.0
S32S STXN R/L 22	SA4	5520	YI4	YE4	SY4	4.0
S40T STXN R/L 22	SA4	5520	YI4	YE4	SY4	4.0
S32S STXN R/L 27	SA5	5525	YI5	YE5	SY5	5.0
S40T STXN R/L 27	SA5	5525	YI5	YE5	SY5	5.0
S50U STXN R/L 27	SA5	5525	YI5	YE5	SY5	5.0
S60V STXN R/L 27	SA5	5525	YI5	YE5	SY5	5.0

### N R/L

Triangular negative inserts for internal threading.  
Plaquetes triangulars negatives de roscat interior. ⓘ C04,06,07,09,10

Reference / Ref.	l	d
11 NR/L..	11,00	6,35
16 NR/L..	16,00	9,52
22 NR/L..	22,00	12,70
27 NR/L..	27,00	15,87

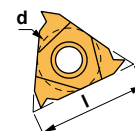

### N R/L



### N R/L TD

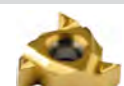



Characteristics:  
Vertical on edge threading boring bar.

Característiques:  
Barra de mandrinar de roscat vertical a l'aresta.

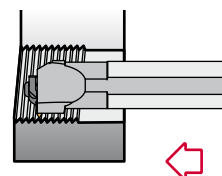
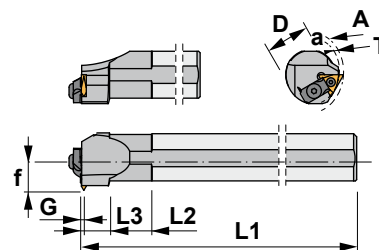

## STGN 90°

Reference Referència	D	L1	L2	L3	f	A	a	T	G	Insert size Mida plaqueta	Kg
S32U STGN R/L 16	32	350	45	19	21,0	50,4	45	2,7	1,59	TNMC 1603..	2,100
S40V STGN R/L 16	40	400	50	19	25,0	60,4	55	2,7	1,59	TNMC 1603..	3,650
S32U STGN R/L 22	32	350	45	28	21,0	78,2	70	4,1	2,38	TNMC 2204..	2,100
S40V STGN R/L 22	40	400	50	28	25,0	50,4	45	4,1	2,38	TNMC 2204..	3,650
S50W STGN R/L 22	50	450	60	28	36,5	60,4	55	4,1	2,38	TNMC 2204..	6,700
S40V STGN R/L 27	40	400	50	28	25,0	60,4	55	6,0	3,18	TNMC 2706..	3,650
S50W STGN R/L 27	50	450	60	28	36,5	78,2	70	6,0	3,18	TNMC 2706..	6,700

Reference Referència						Nm <sup>1</sup>	Nm <sup>2</sup>
S32U STGN R/L 16	1935	2101	1815	5002	5003	1.4	3.0
S40V STGN R/L 16	1935	2101	1815	5002	5003	1.4	3.0
S32U STGN R/L 22	1950	2101	1815	5025	5003	2.0	3.0
S40V STGN R/L 22	1950	2101	1815	5025	5003	2.0	3.0
S50W STGN R/L 22	1950	2101	1815	5025	5003	2.0	3.0
S40V STGN R/L 27	1955	2101	1815	5003	5003	3.0	3.0
S50W STGN R/L 27	1955	2101	1815	5003	5003	3.0	3.0

### TNMC

Triangular negative insert for internal threading. C10  
Plaqueta triangular negativa de roscat interior.

Reference / Ref.	l	s	d
TNMC 1603..	16,50	3,18	9,52
TNMC 2204..	22,00	4,76	12,70
TNMC 2706..	27,00	6,35	15,88

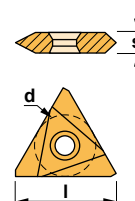

### TNMC





Characteristics:  
Vertical on edge threading boring bar.

Característiques:  
Barra de mandrinar de roscat vertical a l'aresta.

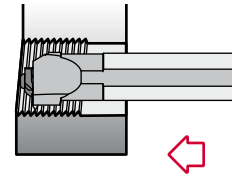
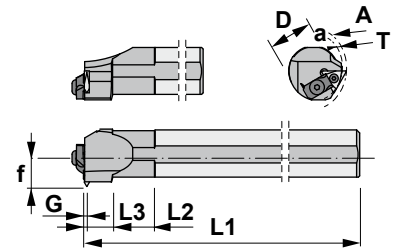

## STGP 90°

Reference Referència	D	L1	L2	L3	f	A	a	T	G	Insert size Mida plaqueta	Kg
S25T STGP R/L 16	25	300	40	19	17,5	50,4	45	2,7	1,59	TPMC 1603..	1,100
S32U STGP R/L 16	32	350	45	19	20,5	50,4	45	2,7	1,59	TPMC 1603..	2,100
S40V STGP R/L 22	40	400	50	28	25,0	78,2	70	4,1	2,38	TPMC 2204..	3,650
S50W STGP R/L 22	50	450	60	28	36,5	78,2	70	4,1	2,38	TPMC 2204..	6,700

Reference Referència						Nm <sup>1</sup>	Nm <sup>2</sup>
S25T STGP R/L 16	1935	2101	1815	5002	5003	1.4	3.0
S32U STGP R/L 16	1935	2101	1815	5002	5003	1.4	3.0
S40V STGP R/L 22	1950	2101	1815	5025	5003	2.0	3.0
S50W STGP R/L 22	1950	2101	1815	5025	5003	2.0	3.0

### TPMC

Triangular positive insert for internal threading. C10  
Plaqueta triangular positiva de roscat interior.

Reference / Ref.	l	s	d
TPMC 1603..	16,50	3,18	9,52
TPMC 2204..	22,00	4,76	12,70

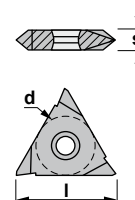

## Cutting data

Material	Cutting speed m/min. (Ft/min) Insert grade			N° of passes		
	PM25	KM15	TIN25	P mm	TPI	N° of passes
Low and medium carbon steel	120-80 (390-260)		250-210 (820-690)	0,50 0,75 1,00 1,25 1,50 1,75 2,00 2,50 3,00	48,0 32,0 24,0 20,0 16,0 14,0 12,0 10,0 8,0	4 - 6 4 - 7 4 - 8 5 - 9 6 - 10 7 - 12 7 - 12 8 - 14 10 - 18
High carbon steel	110-70 (360-230)		210-150 (690-490)	3,50 4,00 4,50 5,00 5,50 6,00 8,00	7,0 6,0 5,5 5,0 4,5 4,0 3,0	11 - 18 11 - 18 11 - 19 12 - 20 12 - 20 12 - 20 15 - 24
Alloyed tool steel and heat-treated steels	100-70 (360-230)		180-140 (590-460)			
Stainless steels	100-70 (360-230)	90-70 (295-230)	140-110 (460-360)			
Cast-iron HB 180-250		90-70 (295-230)				
Non-ferrous metals		180-120 (590-390)				

### General recommendations:

- Threading speeds should normally be a minimum of 80% to 90% of turning speeds being used to machine the same component (assuming grades are compatible).
- Check helix angle and number of passes shown in charts before starting.
- Ensure centre height is correct.
- When there is a problem consult the following recommendations and change only one variable at a time. This will help to be sure of the original problem.
- Do not use flank infeed on work hardening materials.

## Component problems

Problem	Remedy
<b>Pitch error (on CNC machines)</b> <ul style="list-style-type: none"> <li>▼ Starting too close to workpiece.</li> <li>▼ Saddle speed towards chuck is excessive.</li> </ul>	<ul style="list-style-type: none"> <li>▲ Start cycle further back from workpiece.</li> <li>▲ Reduce speed by 10% until correct.</li> </ul>
<b>Thread torn on one side only</b> <ul style="list-style-type: none"> <li>▼ Incorrect helix angle in toolholder.</li> </ul>	<ul style="list-style-type: none"> <li>▲ Check helix chart.</li> <li>▲ Reassemble with correct anvil.</li> <li>▲ Check centre height.</li> </ul>
<b>Thread torn on both sides</b> <ul style="list-style-type: none"> <li>▼ Running too slow.</li> <li>▼ Built up edge.</li> </ul>	<ul style="list-style-type: none"> <li>▲ Increase cutting speed.</li> <li>▲ Check center height.</li> <li>▲ Use coated grade.</li> <li>▲ Compare thread speed with turning speed.</li> </ul>
<b>Long dangerous swarf</b> <ul style="list-style-type: none"> <li>▼ Incorrect chipbreaker geometry.</li> <li>▼ Incorrect method of infeed.</li> </ul>	<ul style="list-style-type: none"> <li>▲ Use Canela (TD) chipbreaker.</li> <li>▲ Use different infeed method.</li> </ul>
<b>Vibration chatter marks on both flanks</b> <ul style="list-style-type: none"> <li>▼ Poor stability.</li> <li>▼ Excessive overhang.</li> </ul>	<ul style="list-style-type: none"> <li>▲ Renew anvil to support insert.</li> <li>▲ Check tool clamping.</li> <li>▲ Reduce tool overhang.</li> <li>▲ Check rigidity of setup.</li> </ul>
<b>Shallow threads Problem with gauging</b> <ul style="list-style-type: none"> <li>▼ Insert not cresting.</li> <li>▼ Incorrect effective diameter.</li> </ul>	<ul style="list-style-type: none"> <li>▲ Check machined diameters.</li> <li>▲ Excessive tool wear or chipped on nose see remedies above.</li> </ul>



## Condicions de tall

Material	Velocitat de tall m/min. (Ft/min) Qualitat de la plaqueta			Nº de passades		
	PM25	KM15	TIN25	P mm	TPI	Nº de passades
Acer amb contingut de carboni baix i mig	120-80 (390-260)		250-210 (820-690)	0,50 0,75 1,00 1,25 1,50 1,75 2,00 2,50 3,00	48,0 32,0 24,0 20,0 16,0 14,0 12,0 10,0 8,0	4 - 6 4 - 7 4 - 8 5 - 9 6 - 10 7 - 12 7 - 12 8 - 14 10 - 18
Acer amb alt contingut de carboni	110-70 (360-230)		210-150 (690-490)	3,50 4,00 4,50 5,00 5,50 6,00 8,00	7,0 6,0 5,5 5,0 4,5 4,0 3,0	11 - 18 11 - 18 11 - 19 12 - 20 12 - 20 12 - 20 15 - 24
Acer aliat per eines i acers tractats	100-70 (360-230)		180-140 (590-460)			
Acers inoxidable	100-70 (360-230)	90-70 (295-230)	140-110 (460-360)			
Fosa HB 180-250		90-70 (295-230)				
Metalls no ferrosos		180-120 (590-390)				

### Recomanacions generals:

- Les velocitats de roscat haurien de ser normalment un mínim de 80% a 90% de les velocitats de tornejat utilitzades per mecanitzar les mateixes peces (sempre que les qualitats siguin compatibles).
- Controlar l'angle de l'hèlix i el nombre de passades indicats en el gràfic abans de començar.
- Assegureu-vos que l'alçada del centre sigui correcta.
- Quan hi hagi un problema, consulteu les recomanacions següents i canvieu només una variable cada cop. Això us ajudarà a saber en tot moment quin era el problema inicial.
- No ataqueu la rosca per el costat quan mecanitzeu materials que s'endureixen al mecanitzar-los.

## Problemes amb les peces

	Problema	Solució
<b>Error de pas (en les màquines CNC)</b>	<ul style="list-style-type: none"> <li>▼ S'ha començat massa a prop de la peça a mecanitzar.</li> <li>▼ Velocitat excessiva envers el capçal de la màquina.</li> </ul>	<ul style="list-style-type: none"> <li>▲ Inicieu el cicle més lluny de la peça a mecanitzar.</li> <li>▲ Reduïu la velocitat un 10% fins que sigui correcta.</li> </ul>
<b>Rosca trencada per una cara</b>	<ul style="list-style-type: none"> <li>▼ Angle de l'hèlix incorrecte en l'eina.</li> </ul>	<ul style="list-style-type: none"> <li>▲ Comproveu l'hèlix en el gràfic.</li> <li>▲ Torneu a muntar amb la placa base correcta.</li> <li>▲ Comproveu l'alçada del centre.</li> </ul>
<b>Rosca trencada per les dues cares</b>	<ul style="list-style-type: none"> <li>▼ Mecanitzat massa lent.</li> <li>▼ Fil d'aportació.</li> </ul>	<ul style="list-style-type: none"> <li>▲ Augmenteu la velocitat de tall.</li> <li>▲ Comproveu l'alçada del centre.</li> <li>▲ Utilitzeu una qualitat recoberta.</li> <li>▲ Compareu la velocitat de roscat amb la velocitat de tornejat.</li> </ul>
<b>Ferritja llarga i perillosa</b>	<ul style="list-style-type: none"> <li>▼ Trencaferritges amb geometria incorrecta.</li> <li>▼ Mètode incorrecte de penetració.</li> </ul>	<ul style="list-style-type: none"> <li>▲ Utilitzeu el trencaferritges TD de Canela.</li> <li>▲ Utilitzeu un mètode de penetració diferent.</li> </ul>
<b>Marques de vibracions als dos costats</b>	<ul style="list-style-type: none"> <li>▼ Poca estabilitat.</li> <li>▼ Voladís excessiu.</li> </ul>	<ul style="list-style-type: none"> <li>▲ Canvieu la placa base per donar millor suport a la plaqueta.</li> <li>▲ Controleu la fixació de l'eina.</li> <li>▲ Reduïu el voladís.</li> <li>▲ Controleu la rigidesa.</li> </ul>
<b>Roscat poc profund Problemes amb la mida</b>	<ul style="list-style-type: none"> <li>▼ La plaqueta no arriba al fons de la rosca.</li> <li>▼ Diàmetre efectiu erroni.</li> </ul>	<ul style="list-style-type: none"> <li>▲ Comproveu els diàmetres mecanitzats.</li> <li>▲ Si hi ha un desgast excessiu o si es trenca la punta de la plaqueta, veieu les solucions indicades anteriorment.</li> </ul>

**Helix chart**

**Feed direction towards the chuck**

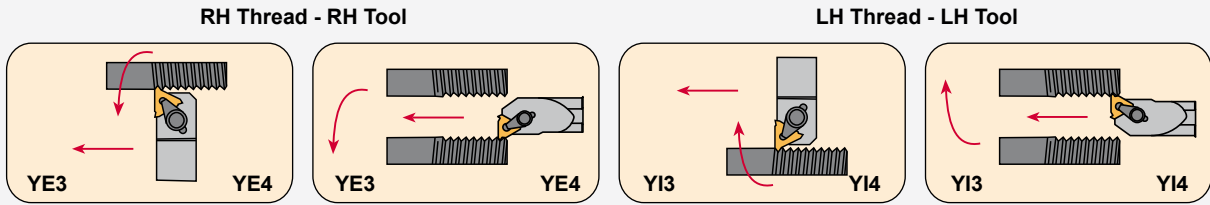

**Anvil to give correct helix**

Insert size	+3°	+2°	+1°	0°
16R	3424+3	3424+2	3424+1	YE3
16L	3425+3	3425+2	3425+1	YI3
22R	3430+3	3430+2	3430+1	YE4
22L	3431+3	3431+2	3431+1	YI4

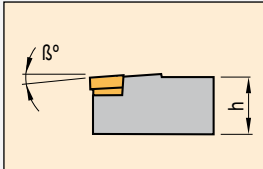
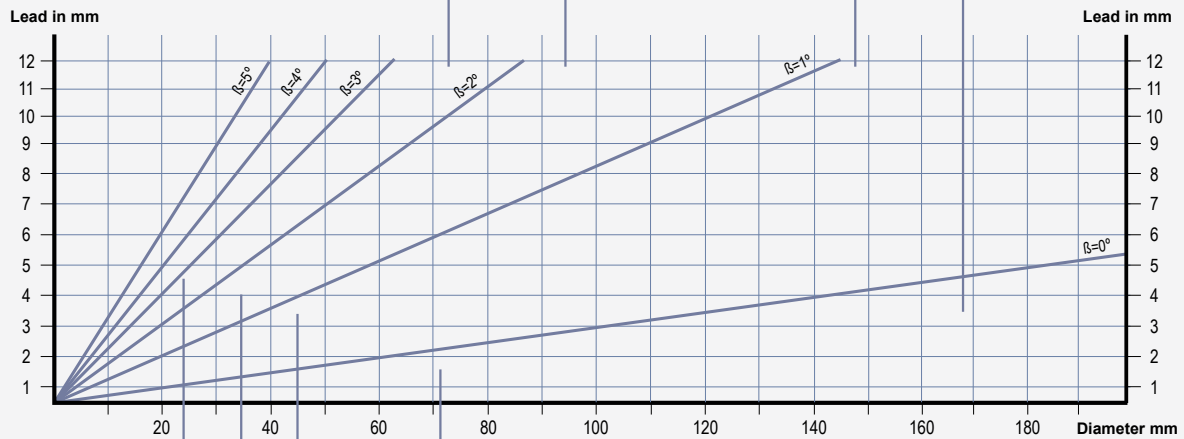

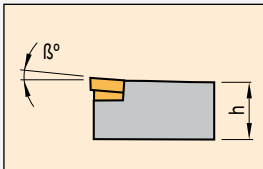

**Anvil to give correct helix**

Insert size	-3°	-2°	-1°	0°
16R	3424-3	3424-2	3424-1	YE3
16L	3425-3	3425-2	3425-1	YI3
22R	3430-3	3430-2	3430-1	YE4
22L	3431-3	3431-2	3431-1	YI4

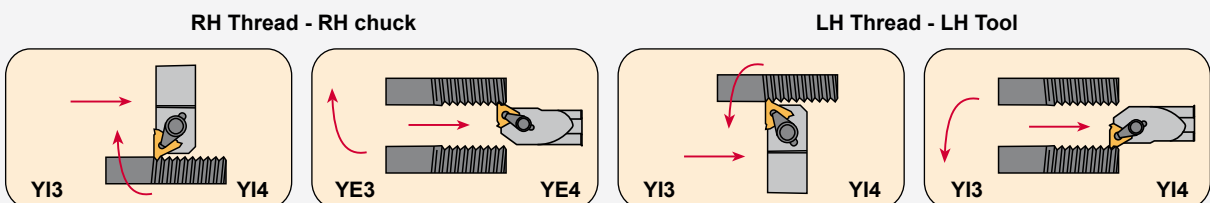

**Feed direction away from the chuck**



**Gràfic de l'hèlix**

**Direcció de l'avanç envers el capçal de la màquina**

Roscat a dreta - Eina a dreta

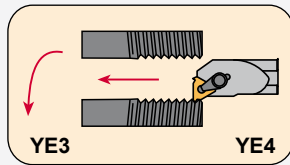
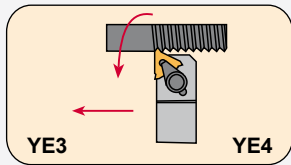

Roscat a esquerra - Eina a esquerra

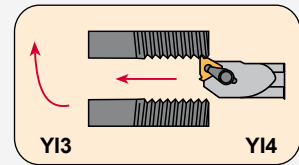
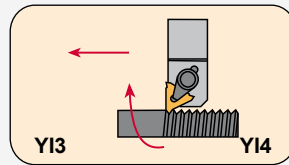

Placa base per obtenir una hèlix correcta

Mida plaqueta	+3°	+2°	+1°	0°
16R	3424+3	3424+2	3424+1	YE3
16L	3425+3	3425+2	3425+1	YI3
22R	3430+3	3430+2	3430+1	YE4
22L	3431+3	3431+2	3431+1	YI4

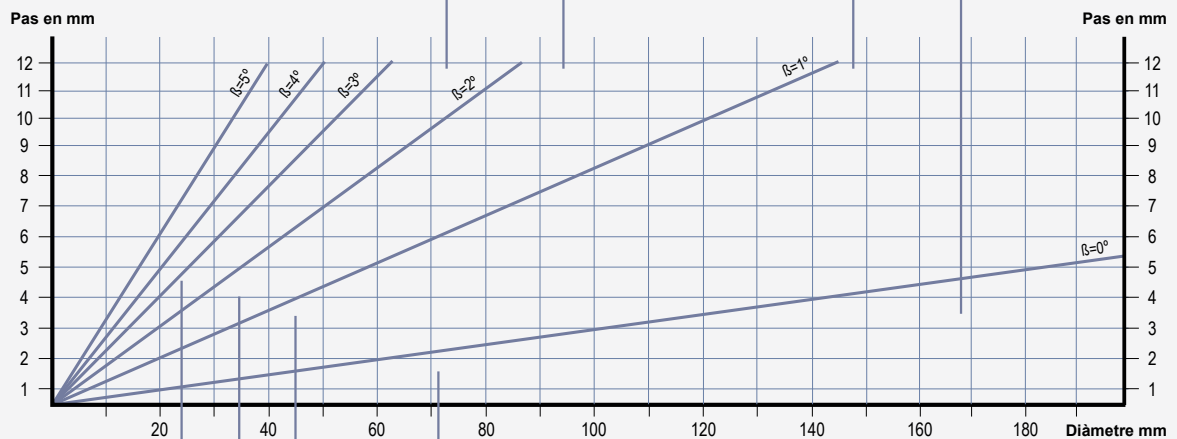
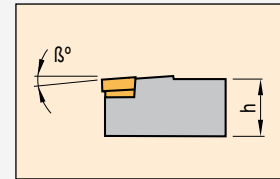

Placa base per obtenir una hèlix correcta

Mida plaqueta	-3°	-2°	-1°	0°
16R	3424-3	3424-2	3424-1	YE3
16L	3425-3	3425-2	3425-1	YI3
22R	3430-3	3430-2	3430-1	YE4
22L	3431-3	3431-2	3431-1	YI4

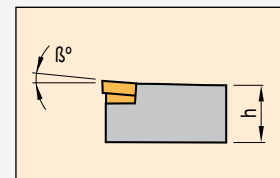

**Direcció de l'avanç procedent del capçal de la màquina**

Roscat a dreta - Eina a dreta

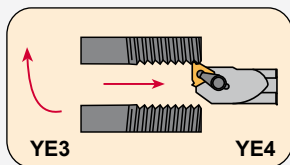
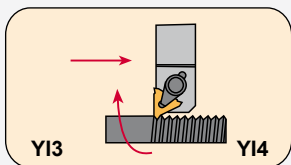

Roscat a esquerra - Eina a esquerra

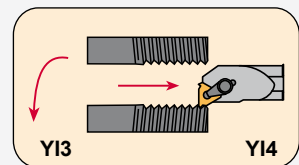
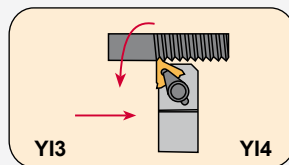



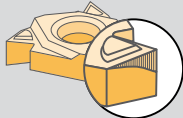
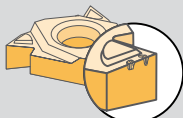
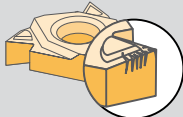
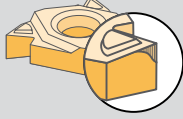
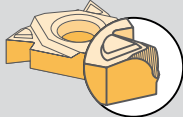
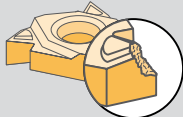

## Threading insert wear and tool life

	Problem	Remedy
<b>Rapid flank wear</b> 	<ul style="list-style-type: none"> <li>▼ Cutting speed too high.</li> <li>▼ Lack of coolant.</li> <li>▼ Infeed per pass too small - too many passes.</li> <li>▼ Incorrect grade.</li> </ul>	<ul style="list-style-type: none"> <li>▲ Reduce the cutting speed.</li> <li>▲ Increase the coolant supply.</li> <li>▲ Increase the depth of infeed for the smallest infeed depths - reduce the number of passes.</li> <li>▲ Select a more wear resistant grade.</li> </ul>
<b>Edge frittering</b> 	<ul style="list-style-type: none"> <li>▼ Instability of workholding and/or tool set-up.</li> </ul>	<ul style="list-style-type: none"> <li>▲ Check rigidity of operation.</li> <li>▲ Select a tougher grade.</li> </ul>
<b>Edge spalling</b> 	<ul style="list-style-type: none"> <li>▼ Intermittent coolant supply.</li> </ul>	<ul style="list-style-type: none"> <li>▲ Position coolant flow and/or increase coolant supply.</li> </ul>
<b>Uneven flank wear</b> 	<ul style="list-style-type: none"> <li>▼ Incorrect method of infeed.</li> <li>▼ Incorrect angle of inclination.</li> </ul>	<ul style="list-style-type: none"> <li>▲ In case of flank infeed use modified flank infeed. Decrease infeed angle 3-5°.</li> <li>▲ Correct the angle on inclination according to the diagram.</li> </ul>
<b>Excessive plastic deformation</b> 	<ul style="list-style-type: none"> <li>▼ Infeed per pass too big - too few passes.</li> <li>▼ Lack of coolant.</li> <li>▼ Cutting speed too high.</li> <li>▼ Incorrect grade.</li> <li>▼ Excessive stock removal from crest.</li> </ul>	<ul style="list-style-type: none"> <li>▲ Decrease the depth of infeed for the biggest depths. - Increase the number of passes.</li> <li>▲ Increase coolant supply.</li> <li>▲ Reduce the cutting speed.</li> <li>▲ Select a harder grade.</li> <li>▲ Check the volume of the material above the crest.</li> </ul>
<b>Insert breakage</b> 	<ul style="list-style-type: none"> <li>▼ Instability.</li> <li>▼ Lack of chip control.</li> <li>▼ Excessive plastic deformation.</li> <li>▼ Intermittent or inadequate coolant supply.</li> <li>▼ Incorrect preparation of the operation.</li> </ul>	<ul style="list-style-type: none"> <li>▲ Check rigidity of operation.</li> <li>▲ Select a tougher grade. Select modified flank infeed.</li> <li>▲ Machine with same infeed per pass.</li> <li>▲ Direct coolant flow and/or increase coolant supply.</li> <li>▲ Check dimension of blank.</li> </ul>
<b>Shallow thread profile</b>	<ul style="list-style-type: none"> <li>▼ Wrong centre height.</li> <li>▼ Insert not cresting.</li> <li>▼ Excessive tool wear.</li> </ul>	<ul style="list-style-type: none"> <li>▲ Adjust cutting edge height.</li> <li>▲ Check dimension of blank.</li> <li>▲ Change insert earlier.</li> </ul>
<b>Incorrect thread profile</b>	<ul style="list-style-type: none"> <li>▼ Incorrect tool setting.</li> </ul>	<ul style="list-style-type: none"> <li>▲ Correct tool setting.</li> </ul>
<b>Lack of chip control</b>	<ul style="list-style-type: none"> <li>▼ Incorrect depth of infeed per pass.</li> <li>▼ Radial infeed.</li> </ul>	<ul style="list-style-type: none"> <li>▲ For modified flank infeed use 3-5°.</li> <li>▲ Use geometry with modified flank infeed 1°.</li> </ul>
<b>Bad surface finish</b>	<ul style="list-style-type: none"> <li>▼ Cutting speed too low.</li> <li>▼ Incorrect angle of inclination.</li> <li>▼ Flank infeed.</li> </ul>	<ul style="list-style-type: none"> <li>▲ Increase the cutting speed.</li> <li>▲ Correct the angle of inclination according to diagram.</li> <li>▲ Use modified flank infeed or radial infeed.</li> </ul>

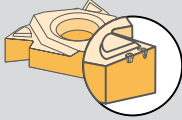
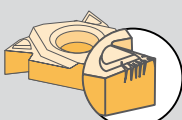
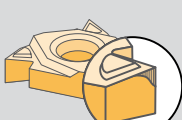
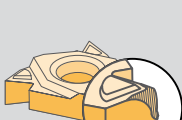

## Desgast i duració de la plaqueta de roscat

	Problema	Solució
<p><b>Desgast ràpid en incidència</b></p> 	<ul style="list-style-type: none"> <li>▼ Velocitat de tall massa alta.</li> <li>▼ Manca de refrigerant.</li> <li>▼ Penetració per passada massa petita - masses passades.</li> <li>▼ Qualitat incorrecta.</li> </ul>	<ul style="list-style-type: none"> <li>▲ Reduïu la velocitat de tall.</li> <li>▲ Incrementeu el subministrament de refrigerant.</li> <li>▲ Incrementeu la profunditat de penetració per passada - reduïu el nombre de passades.</li> <li>▲ Seleccioneu una qualitat més resistent al desgast.</li> </ul>
<p><b>Estellament de l'aresta</b></p> 	<ul style="list-style-type: none"> <li>▼ Inestabilitat de la subjecció i/o del muntatge de l'eina.</li> </ul>	<ul style="list-style-type: none"> <li>▲ Controlar l'estabilitat de l'operació.</li> <li>▲ Seleccioneu una qualitat més tenaç.</li> </ul>
<p><b>Fissures tèrmiques a l'aresta</b></p> 	<ul style="list-style-type: none"> <li>▼ Subministrament discontinu del refrigerant.</li> </ul>	<ul style="list-style-type: none"> <li>▲ Corregiu la posició de sortida del refrigerant i/o augmenteu el subministrament.</li> </ul>
<p><b>Desgast desigual a l'incidència</b></p> 	<ul style="list-style-type: none"> <li>▼ Mètode incorrecte de penetració.</li> <li>▼ Angle d'inclinació incorrecte.</li> </ul>	<ul style="list-style-type: none"> <li>▲ En cas de penetració lateral, utilitzeu penetració lateral modificada. Disminuiu l'angle de penetració de 3°-5°.</li> <li>▲ Corregiu l'inclinació de l'angle segons el diagrama.</li> </ul>
<p><b>Deformació plàstica excessiva</b></p> 	<ul style="list-style-type: none"> <li>▼ Penetració per passada massa gran - massa poques passades.</li> <li>▼ Manca de refrigeració.</li> <li>▼ Velocitat de tall massa alta.</li> <li>▼ Qualitat incorrecta.</li> <li>▼ Extracció excessiva de material del fons de la rosca.</li> </ul>	<ul style="list-style-type: none"> <li>▲ Reduïu la profunditat de penetració per passada - augmenteu el nombre de passades.</li> <li>▲ Augmenteu el subministrament de refrigerant.</li> <li>▲ Reduïu la velocitat de tall.</li> <li>▲ Seleccioneu una qualitat més dura.</li> <li>▲ Comproveu el volum de material en el fons de la rosca.</li> </ul>
<p><b>Trencament de la plaqueta</b></p> 	<ul style="list-style-type: none"> <li>▼ Inestabilitat.</li> <li>▼ Manca de control de la ferritja.</li> <li>▼ Excessiva deformació plàstica.</li> <li>▼ Subministrament del refrigerant discontinu o inadequat.</li> <li>▼ Preparació incorrecta de l'operació.</li> </ul>	<ul style="list-style-type: none"> <li>▲ Comproveu l'estabilitat de l'operació.</li> <li>▲ Seleccioneu una qualitat més tenaç. Seleccioneu penetració lateral modificada.</li> <li>▲ Mecanitzeu amb la mateixa penetració per passada.</li> <li>▲ Corregiu la posició de la sortida del refrigerant i/o augmenteu el subministrament.</li> <li>▲ Comproveu la mida de la plaqueta.</li> </ul>
<p><b>Perfil de la rosca poc profund</b></p>	<ul style="list-style-type: none"> <li>▼ Alçada central errònia.</li> <li>▼ La plaqueta no arriba al fons de la rosca.</li> <li>▼ Desgast excessiu de la plaqueta.</li> </ul>	<ul style="list-style-type: none"> <li>▲ Ajusteu l'alçada de l'aresta de tall.</li> <li>▲ Comproveu la mida de la plaqueta.</li> <li>▲ Canvieu la plaqueta abans.</li> </ul>
<p><b>Perfil de la rosca incorrecte</b></p>	<ul style="list-style-type: none"> <li>▼ Muntatge incorrecte de l'eina.</li> </ul>	<ul style="list-style-type: none"> <li>▲ Corregiu el muntatge de l'eina.</li> </ul>
<p><b>Manca de control de la ferritja</b></p>	<ul style="list-style-type: none"> <li>▼ Profunditat de penetració per passada incorrecta.</li> <li>▼ Penetració radial.</li> </ul>	<ul style="list-style-type: none"> <li>▲ Utilitzeu penetració lateral modificada de 3°-5°.</li> <li>▲ Utilitzeu penetració lateral modificada a 1°.</li> </ul>
<p><b>Mal acabat de superfície</b></p>	<ul style="list-style-type: none"> <li>▼ Velocitat de tall massa lenta.</li> <li>▼ Angle d'inclinació incorrecte.</li> <li>▼ Penetració lateral.</li> </ul>	<ul style="list-style-type: none"> <li>▲ Incrementeu la velocitat de tall.</li> <li>▲ Corregiu l'angle d'inclinació d'acord amb el diagrama.</li> <li>▲ Utilitzeu penetració lateral modificada o penetració radial.</li> </ul>