



# HSK DIN 69893-1

Code system Kodifizierung	<b>178</b>
Technical information Technische Auskünfte	<b>179</b>
Applications index Anwendungen	<b>180</b>
Arbors and adaptors HSK DIN 69893-1 Aufnahmen HSK DIN 69893-1	<b>181-96</b>
Antivibratory adaptors HSK DIN 69893-1 Schwingungsgedämpfte Aufnahmen HSK DIN 69893-1	<b>182-83,91</b>
Special tool request Sonderwerkzeug-Anfrage	<b>197</b>



## Code system / Kodifizierung

**A** **16** **160** **063** **22**

**\*** **1** **2** **3** **4**

**\*** **Antivibratory adaptors**  
**Schwingungsgedämpfte Aufnahmen**

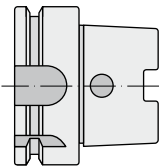
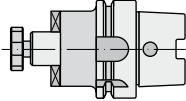
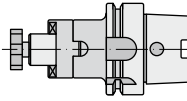
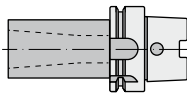
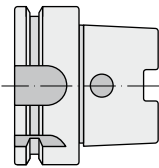
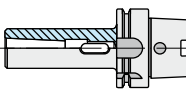
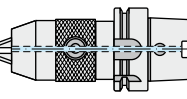
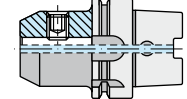
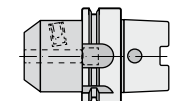
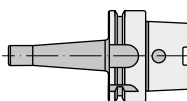
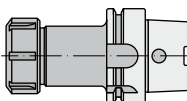
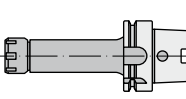
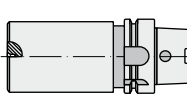
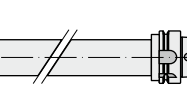
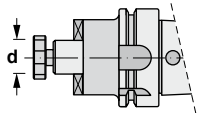
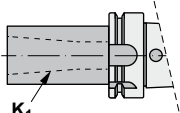
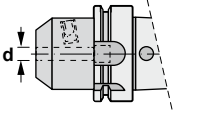
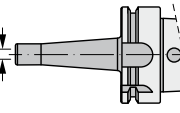
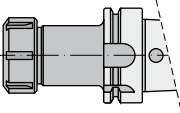
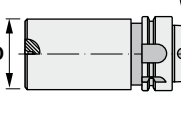
1 <b>Model</b> <b>Modell</b>	2 <b>Arbor type</b> <b>Aufnahmen-Typ</b>			
HSK DIN 69893-1  16	 160	 180	 210	
3 <b>Arbor size</b> <b>Aufnahmegröße</b> HSK DIN 69893-1  63      100	 215	 296	 300	
	 305	 315	 453	
	 455	 470	 999	
4 <b>Adaptor size</b> <b>Adaptergröße</b>  Ø 16 <b>16</b>	K <sub>1</sub> - MORSE  K <sub>1</sub> MK1 MK2 MK3 MK4 MK5 <b>01 02 03 04 05</b>			
 Ø 6 ... Ø 40 <b>6 ... 40</b>	 M <b>M18 M21 M29</b>	 ER16 ER20 ER25 ER32 ER40 <b>16 20 25 32 40</b>	 Ø 6 ... Ø 40 <b>6 ... 40</b>	

## AT3 TECHNICAL CHARACTERISTICS OF THE TOOLHOLDERS AT3 TECHNISCHE EIGENSCHAFTEN DER AUFNAHMEN

### MATERIAL:

- Chromium-manganese carburised steel 1.7131 (16MnCr5).

### EXECUTION:

- Carburised, hardened and tempered.
- Surface hardness HRC 58±2 (670±40 HV30)
- Depth of carburised layer minimum 0,5 mm.
- Tensile strength in core minimum 800 N/mm<sup>2</sup> after carburizing.

### ACCURACY:

- Taper according to DIN 254
- Taper angle:  
tolerance AT 3 DIN 7178 part 1 and DIN 2080 part 1.
- Other tolerances according to DIN 7160 and 7168.
- Taper surface roughness RZ<0,001 mm.

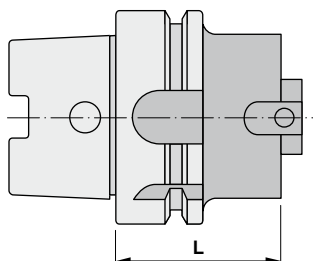

### PREBALANCED TOOLHOLDERS VORGEWUCHTETE AUFNAHMEN

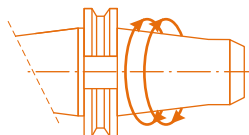

ISO 40 ▶ 8000 rpm

ISO 50 ▶ 8000 rpm

### MATERIALIEN:

- Legierter aufgekohlter Stahl mit Chrom-Mangan 1.7131 (16MnCr5).

### KONSTRUKTIONS DATEN:

- Aufgekühlt, gehärtet und angelassen.
- Oberflächenhärte HRC 58±2 (670±40 HV30)
- Aufgekühlt auf minimum 0,5 mm Tiefe.
- Zugfestigkeit im Kern minimum 800 N/mm<sup>2</sup> nach der Aufkohlung.

### GENAUIGKEIT:

- Dorn nach DIN 254
- Kegelminkel:  
Toleranz AT 3 DIN 7178 Teil 1 und DIN 2080 Teil 1.
- Andere Toleranzen entsprechend DIN 7160 und 7168.
- Rauigkeit der Oberfläche RZ<0,001 mm.

K	AT3 mm
ISO 30	0,002
ISO 40	0,003
ISO 45	0,003
ISO 50	0,004
ISO 60	0,005

### TOLERANCE AT:

- Indicates the tolerance of measuring plane D between the real and the theoretical value of the taper conicity.
- This value of measuring plane D must always be less (negative), never more (positive) in order to GUARANTEE a good toolholder fixation at the bigger taper diameter.

### TOLERANZ AT:

- Zeigt die Toleranz auf der Messebene D zwischen dem tatsächlichen Wert der Kegelminkelkonizität und dem theoretischen Wert.
- Dieser Wert auf der Messebene D sollte immer minus (negativ) sein, nie plus (positiv), um für einen guten Halt des Futter in den größeren Durchmesser des Kegels zu GARANTIEREN.

## 16 DIN 69893-HSK-A

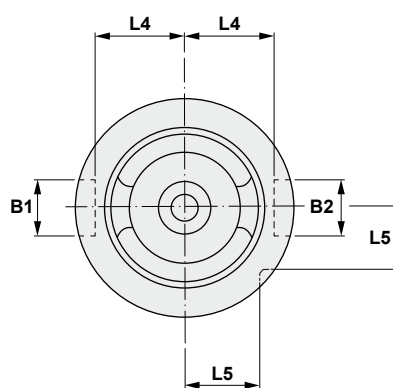
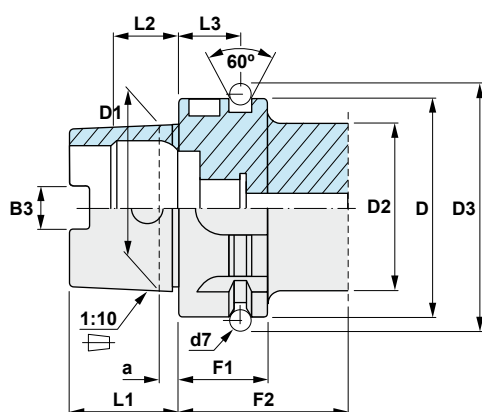

HSK	Dh10	D1	D2 max	D3 -0,1	B1 H10	B2 H10	B3±0,4	d7	L1 -0,2	L2Js10	L3±0,1	L4 -0,2	L5 -0,3	F1 -0,1	F2 min	a
32	32	24	26	37,0	9	7	7,05	4	16	8,92	16	13,0	9,5	20	35	3,2
40	40	30	34	45,0	11	9	8,05	4	20	11,42	16	17,0	12,0	20	35	4,0
50	50	38	42	59,3	14	12	10,54	7	25	14,13	18	21,0	15,5	26	42	5,0
63	63	48	53	72,3	18	16	12,54	7	32	18,13	18	26,5	20,0	26	42	3,3
80	80	60	67	88,8	20	18	16,04	7	40	22,85	18	34,0	25,0	26	42	8,0
100	100	75	85	109,75	22	20	20,02	7	50	28,56	20	44,0	31,5	29	45	10,0

**Arbors and adaptors HSK DIN 69893-1**  
**Aufnahmen HSK DIN 69893-1**

16.160



Page / Seite 181

16.180



Page / Seite 184

16.210



Page / Seite 185

16.215



Page / Seite 186

16.296



Page / Seite 187

16.300



Page / Seite 188-89

16.305



Page / Seite 190

16.315



Page / Seite 192

16.453



Page / Seite 193

16.455



Page / Seite 194

16.470



Page / Seite 195

16.999



Page / Seite 196

**Antivibratory adaptors HSK DIN 69893-1**  
**Schwingungsgedämpfte Aufnahmen HSK DIN 69893-1**

A16.160IK



Page / Seite 182

A16.160



Page / Seite 183

A16.315IK



Page / Seite 191



**Characteristics:**

Shell mill adaptors. DIN 69893-1 / HSK Form A  
For cutters with driving slot DIN 138.

**Eigenschaften:**

Aufsteckfräsdorne DIN 69893-1 / HSK Form A.  
Für Fräser mit Quernut DIN 138.

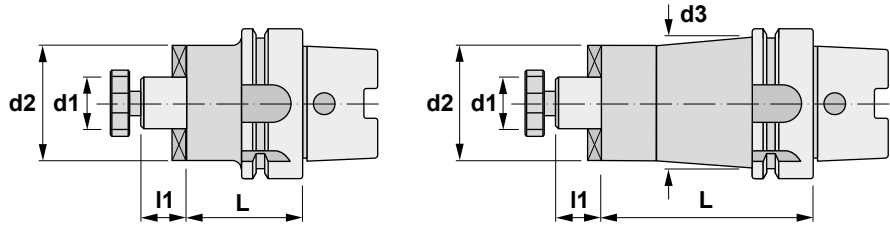

## 16.160

Reference Bezeichnung	HSK	d1	L	I1	d2	d3				
16.160.063.16	63	16	50	17	38	-	10008	86016	11103	0,880
16.160.063.16/100	63	16	100	17	38	46	10008	86016	11103	1,420
16.160.063.16/160	63	16	160	17	38	46	10008	86016	11103	2,050
16.160.063.22	63	22	50	19	47	-	10010	86022	11004	1,020
16.160.063.22/100	63	22	100	19	47	53	10010	86022	11004	1,810
16.160.063.22/160	63	22	160	19	48	53	10010	86022	11004	2,720
16.160.063.27	63	27	60	21	58	-	10012	86027	11005	1,420
16.160.063.27/100	63	27	100	21	58	-	10012	86027	11005	2,240
16.160.063.27/160	63	27	160	21	58	-	10012	86027	11005	3,450
16.160.063.32	63	32	60	24	64	-	10016	86032	11105	1,620
16.160.063.32/100	63	32	100	24	64	-	10016	86032	11105	2,470
16.160.063.32/160	63	32	160	24	64	-	10016	86032	11105	3,960
16.160.063.40	63	40	60	27	80	-	10020	86040	11006	2,130
16.160.063.40/100	63	40	100	27	80	-	10020	86040	11006	3,960
16.160.100.16	100	16	50	17	38	-	10008	86016	11103	2,320
16.160.100.22	100	22	50	19	48	-	10010	86022	11004	2,450
16.160.100.27	100	27	50	21	55	-	10012	86027	11005	2,570
16.160.100.32	100	32	50	24	64	-	10016	86032	11105	2,740
16.160.100.40	100	40	60	27	80	-	10020	86040	11006	3,490





**Characteristics:**



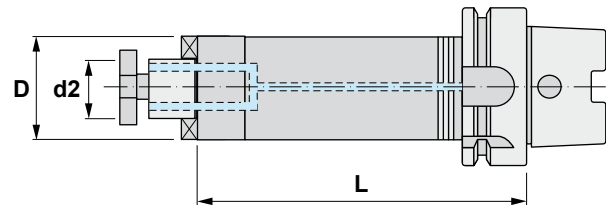

Cylindrical antivibratory shell mill adaptors.  
DIN 69893-1 / HSK Form A  
For cutters with driving slot DIN 138.  
With internal coolant.

**Eigenschaften:**

Schwingungsgedämpfte Aufsteckfräsdorne.  
DIN 69893-1 / HSK Form A  
Für Fräser mit Quernut DIN 138.  
Mit Innenkühlung.



## A16.160IK

Reference Bezeichnung	HSK	L	D	d2				
A16.160.063.16/200-38IK	63	200	38	16	10008	86016	11103	2,150
A16.160.063.16/300-38IK	63	300	38	16	10008	86016	11103	3,000
A16.160.063.22/200-48IK	63	200	48	22	10010	86022	11004	3,100
A16.160.063.22/300-48IK	63	300	48	22	10010	86022	11004	4,480
A16.160.063.27/300-58IK	63	300	58	27	10012	86027	11005	4,230
A16.160.100.16/200-38IK	100	200	38	16	10008	86016	11103	3,580
A16.160.100.16/300-38IK	100	300	38	16	10008	86016	11103	4,430
A16.160.100.22/200-48IK	100	200	48	22	10010	86022	11004	4,510
A16.160.100.22/300-48IK	100	300	48	22	10010	86022	11004	5,890
A16.160.100.27/200-58IK	100	200	58	27	10012	86027	11005	5,630
A16.160.100.27/300-58IK	100	300	58	27	10012	86027	11005	7,640
A16.160.100.32/300-78IK	100	300	78	32	10016	86032	11105	10,210



**Characteristics:**  
 Cylindrical antivibratory shell mill adaptors.  
 DIN 69893-1 / HSK Form A  
 For cutters with driving slot DIN 138.

**Eigenschaften:**  
 Schwingungsgedämpfte Aufsteckfräsdorne.  
 DIN 69893-1 / HSK Form A  
 Für Fräser mit Quernut DIN 138.

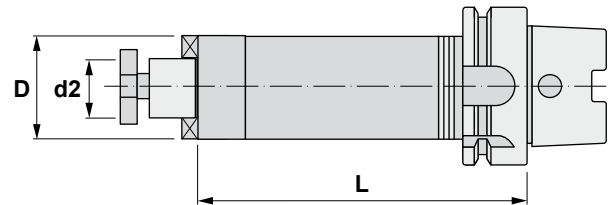

## A16.160

Reference Bezeichnung	HSK	L	D	d2				
A16.160.063.16/200-38	63	200	38	16	10008	86016	11103	2,150
A16.160.063.16/300-38	63	300	38	16	10008	86016	11103	3,000
A16.160.063.22/200-48	63	200	48	22	10010	86022	11004	3,100
A16.160.063.22/300-48	63	300	48	22	10010	86022	11004	4,480
A16.160.063.27/200-58	63	200	58	27	10012	86027	11005	4,230
A16.160.063.27/300-58	63	300	58	27	10012	86027	11005	5,340
A16.160.100.16/200-38	100	200	38	16	10008	86016	11103	3,580
A16.160.100.16/300-38	100	300	38	16	10008	86016	11103	4,430
A16.160.100.22/200-48	100	200	48	22	10010	86022	11004	4,510
A16.160.100.22/300-48	100	300	48	22	10010	86022	11004	5,890
A16.160.100.27/200-58	100	200	58	27	10012	86027	11005	5,630
A16.160.100.27/300-58	100	300	58	27	10012	86027	11005	7,640
A16.160.100.32/300-78	100	300	78	32	10016	86032	11105	10,210

### SPECIAL FOR MOULD AND DIE MAKERS

Vibration reduced up to 60% compared to any other conventional shell mill adaptor, as they are manufactured with materials and mechanisms having antivibration properties.

### BESONDERS EMPFOHLEN FÜR WERKZEUG- UND FORMENBAU

60% weniger Schwingungen im Vergleich mit anderen konventionellen Aufsteckfräsdornen, da diese Ausführung mit schwingungsdämpfenden Materialien und Mechanismen hergestellt wird.

### COMPARISON WHEN USING AN ANTIVIBRATORY TOOLHOLDER

### VERGLEICH ZWISCHEN EINER KONVENZIONELLEN UND EINER SCHWINGUNGSGEDÄMPFTEN AUFNAHME

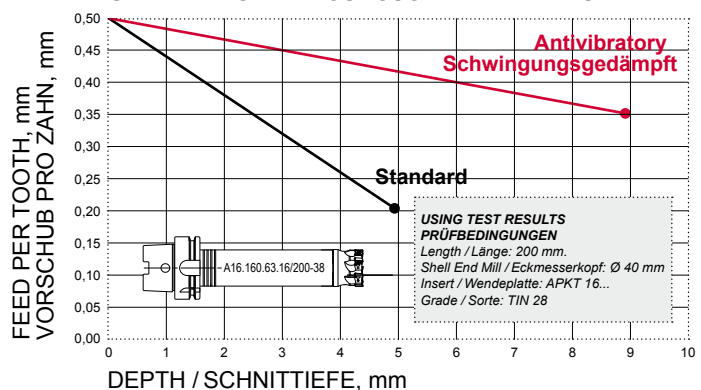



**Characteristics:**



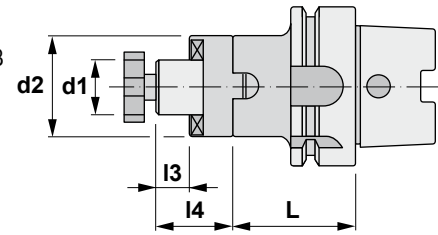

Combi-Shell mill adaptor.  
HSK Form A / DIN 69893-1 / DIN 6358 - Form B  
For cutters with keyway or driving slot DIN 138.

**Eigenschaften:**

Kombi-Aufsteckfräsdorne.  
HSK Form A / DIN 69893-1 / DIN 6358 - Form B  
Für Fräser mit Längsnut oder Stimmritzhemer DIN 138



## 16.180

Reference Bezeichnung	HSK	d1 h6	L	l3	l4	d2				
16.180.063.16	63	16	55	17	27	32	10008	60116	88016	0,910
16.180.063.16/100	63	16	100	17	27	32	10008	60116	88016	1,170
16.180.063.22	63	22	55	19	31	40	10010	60122	88022	1,090
16.180.063.22/100	63	22	100	19	31	40	10010	60122	88022	1,510
16.180.063.27	63	27	55	21	33	48	10012	60127	88027	1,290
16.180.063.27/100	63	27	100	21	33	48	10012	60127	88027	1,910
16.180.063.32	63	32	60	24	38	58	10016	60132	88032	1,740
16.180.063.32/100	63	32	100	24	38	58	10016	60132	88032	2,550
16.180.063.40	63	40	60	27	41	70	10020	60140	88040	2,270
16.180.063.40/100	63	40	100	27	41	70	10020	60140	88040	3,460
16.180.100.16	100	16	55	17	27	32	10008	60116	88016	2,350
16.180.100.22	100	22	55	19	31	40	10010	60122	88022	2,520
16.180.100.27	100	27	55	21	33	48	10012	60127	88027	2,710
16.180.100.32	100	32	60	24	38	58	10016	60132	88032	3,110
16.180.100.40	100	40	60	27	41	70	10020	60140	88040	3,590







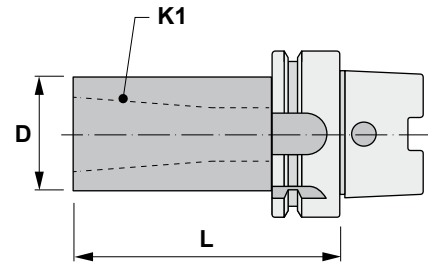

**Characteristics:**  
 Reducing adaptors.  
 DIN 69893-1 / HSK Form A  
 For tools with Morse taper shank  
 and drawbar thread DIN 228-A.

**Eigenschaften:**  
 Reduzierhülsen.  
 DIN 69893-1 / HSK Form A  
 Für Werkzeuge mit Morsekegel  
 und Anzugsgewinde DIN 228-A.



## 16.210

Reference Bezeichnung	HSK	K1 MORSE	L	D	
16.210.063.01	63	1	100	25	0,890
16.210.063.02	63	2	120	32	1,110
16.210.063.03	63	3	140	40	1,490
16.210.063.04	63	4	160	48	1,960
16.210.100.02	100	2	120	32	2,530
16.210.100.03	100	3	150	40	2,990
16.210.100.04	100	4	170	48	3,500
16.210.100.05	100	5	200	63	4,630

Reference Bezeichnung			
16.210.063.01	16205	19624	18006
16.210.063.02	16205	19324	18110
16.210.063.03	16205	19524	18112
16.210.063.04	16205	19424	18016
16.210.100.02	16205	19324	18110
16.210.100.03	16205	19524	18112
16.210.100.04	16205	19424	18016
16.210.100.05	16205	19338	18020





**Characteristics:**  
Reducing adaptors.  
DIN 69893-1 / HSK Form A  
For tools with Morse taper shank  
and tang or drawbar DIN 228-B.

**Eigenschaften:**  
Reduzierhülsen.  
DIN 69893-1 / HSK Form A.  
Für Werkzeuge mit Morsekegel  
und Austreibblappen oder  
Anzugsgewinde DIN 228-B.

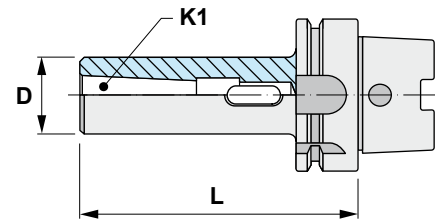

## 16.215

Reference Bezeichnung	HSK	K1 MORSE	L	D	
16.215.063.01	63	1	100	25	0,890
16.215.063.02	63	2	120	32	1,110
16.215.063.03	63	3	140	40	1,490
16.215.063.04	63	4	160	48	1,960
16.215.100.02	100	2	120	32	2,530
16.215.100.03	100	3	150	40	2,990
16.215.100.04	100	4	170	48	3,500
16.215.100.05	100	5	200	63	4,630



Characteristics:  
CNC-Universal precision drill chucks.  
DIN 69893-1 / HSK Form A  
For left and right hand turn and with  
internal coolant.

**\* SUPPLIED WITH WRENCH**

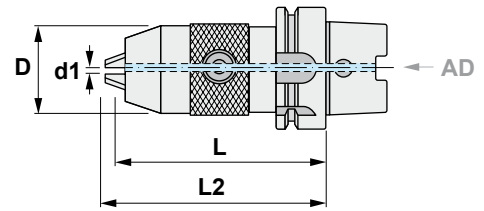

Eigenschaften:  
CNC-Universal Bohrfutter,  
Genauigkeitsausführung DIN  
69893-1 / HSK Form A  
Für links- und rechtslaufende  
Bearbeitungen und mit Innenkühlung.

**\* LIEFERUNG MIT SCHLÜSSEL**



## 16.296

Reference Bezeichnung	HSK	d1	D	L	L2 max	
16.296.063.13	63	1-13	54	98	107	1,480
16.296.063.16	63	3-16	57	109	108	1,750
16.296.100.13	100	1-13	54	110	119	3,070
16.296.100.16	100	3-16	57	113	120	3,370

Reference Bezeichnung		3x 
16.296.063.13	5006	60313
16.296.063.16	5006	60313
16.296.100.13	5006	60313
16.296.100.16	5006	60313





**Characteristics:**



Weldon end mill adaptors. DIN 69893-1 / HSK Form A.  
For cutters with cylindrical shank and Weldon flat DIN 1835-B.

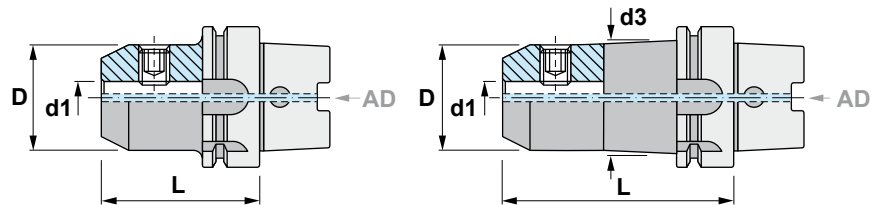

**Eigenschaften:**

Zylinderschaft-Aufnahme Weldon DIN 69893-1 / HSK Form A.  
Für Fräser mit zylindrischem Schaft und Weldon-Fläche DIN 1835-B.



## 16.300

Reference Bezeichnung	HSK	d1 H4	L	D	d3		
16.300.063.06	63	6	65	25	-	15106	0,780
16.300.063.06/160	63	6	160	25	30	15106	1,210
16.300.063.08	63	8	65	28	-	15108	0,810
16.300.063.08/160	63	8	160	28	32	15108	1,310
16.300.063.10	63	10	65	35	-	15110	0,900
16.300.063.10/160	63	10	160	35	32	15110	1,680
16.300.063.12	63	12	80	42	-	15212	1,150
16.300.063.12/160	63	12	160	42	45	15212	2,030
16.300.063.14	63	14	80	44	-	15212	1,190
16.300.063.14/160	63	14	160	44	48	15212	2,150
16.300.063.16	63	16	80	48	-	15314	1,290
16.300.063.16/160	63	16	160	48	52	15314	2,410
16.300.063.18	63	18	80	50	-	15314	1,330
16.300.063.18/160	63	18	160	50	52	15314	2,460
16.300.063.20	63	20	80	52	-	15216	1,360
16.300.063.20/160	63	20	160	52	-	15216	2,500
16.300.063.25	63	25	110	65	-	2 x 15218	2,280
16.300.063.32	63	32	110	72	-	2 x 15220	2,480
16.300.100.06	100	6	80	25	-	15106	2,280
16.300.100.06/160	100	6	160	25	30	15106	2,660
16.300.100.08	100	8	80	28	-	15108	2,320
16.300.100.08/160	100	8	160	28	32	15108	2,750
16.300.100.10	100	10	80	35	-	15110	2,440
16.300.100.10/160	100	10	160	35	32	15110	3,100
16.300.100.12	100	12	80	42	-	15212	2,570
16.300.100.12/160	100	12	160	42	45	15212	3,450
16.300.100.14	100	14	80	44	-	15212	2,600
16.300.100.14/160	100	14	160	44	48	15212	3,570
16.300.100.16	100	16	100	48	-	15314	2,950
16.300.100.16/160	100	16	160	48	52	15314	3,810
16.300.100.18	100	18	100	50	-	15314	2,990
16.300.100.18/160	100	18	160	50	52	15314	3,850

Reference Bezeichnung	HSK	d1 H4	L	D	d3		
16.300.100.20	100	20	100	52	-	15216	3,040
16.300.100.20/160	100	20	160	52	-	15216	3,890
16.300.100.25	100	25	100	65	-	2 x 15218	3,550
16.300.100.25/160	100	25	160	65	-	2 x 15218	4,890
16.300.100.32	100	32	100	72	-	2 x 15220	3,780
16.300.100.40	100	40	100	80	-	2 x 15024	3,960

**42.300**

 1182

Ref. / Bez.	Accessories / Zubehör
42.300	Short and long reducing bushings DIN 1835-B Form A and B Kurze und lange Reduzierhülsen DIN 1835-B Form A und B





**Characteristics:**



End mill adaptors type Whistle-Notch.  
DIN 69893-1 / HSK Form A.  
For tools with cylindrical shank and  
tightening inclined flat DIN 1835-E.

**Eigenschaften:**

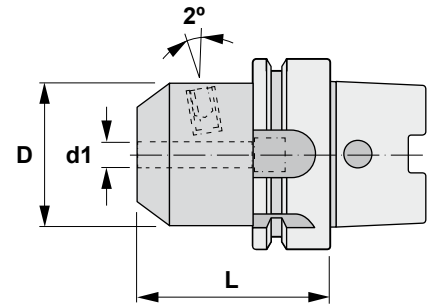
Whistle-Notch Zylinderschaft-Aufnahme.  
DIN 69893-1 / HSK Form A.  
Für Werkzeuge mit zylindrischem Schaft  
und geneigter Spannfläche DIN 1835-E.



## 16.305

Reference Bezeichnung	HSK	d1 H4	L	D			
16.305.063.06	63	6	80	25	19005	15106	0,830
16.305.063.08	63	8	80	28	19106	15108	0,880
16.305.063.10	63	10	80	35	19008	15110	1,000
16.305.063.12	63	12	90	42	19110	15212	1,250
16.305.063.14	63	14	90	44	19110	15212	1,300
16.305.063.16	63	16	100	48	19012	15314	1,540
16.305.063.18	63	18	100	50	19012	15314	1,590
16.305.063.20	63	20	100	52	19016	15216	1,650
16.305.063.25	63	25	110	65	19020	15218	2,280
16.305.063.32	63	32	115	72	19020	15220	2,610
16.305.100.06	100	6	90	25	19005	15106	2,320
16.305.100.08	100	8	90	28	19106	15108	2,370
16.305.100.10	100	10	90	35	19008	15110	2,510
16.305.100.12	100	12	100	42	19110	15212	2,770
16.305.100.14	100	14	100	44	19110	15212	2,820
16.305.100.16	100	16	100	48	19012	15314	2,940
16.305.100.18	100	18	100	50	19012	15314	2,990
16.305.100.20	100	20	100	52	19016	15216	3,040
16.305.100.25	100	25	120	65	19020	15218	4,000
16.305.100.32	100	32	120	72	19020	15220	4,290
16.305.100.40	100	40	130	80	19020	15220	4,850





**Characteristics:**

Antivibratory end mill adaptors.  
 HSK DIN 69893-1  
 For frontal end mill support screwed shanks.  
 Manufactured with materials and mechanisms having antivibration properties.  
 Standard and extra long lengths, suitable for moulding and special manufactures.  
 With internal coolant.

**PRE-BALANCED**

ISO-40: 15.000 r.p.m. G-6,3  
 ISO-50: 10.000 r.p.m. G-6,3

**Eigenschaften:**

Schwingungsgedämpfte Aufsteckfräsdome für Einschraubfräser.  
 HSK DIN 69893-1  
 Hergestellt mit schwingungsdämpfenden Materialien und Mechanismen.  
 Standard und extralange Ausführungen sind für Werkzeug- und Formenbau besonders geeignet.  
 Mit Innenkühlung.

**VORGEWUCHTET**

ISO-40: 15.000 r.p.m. G-6,3  
 ISO-50: 10.000 r.p.m. G-6,3

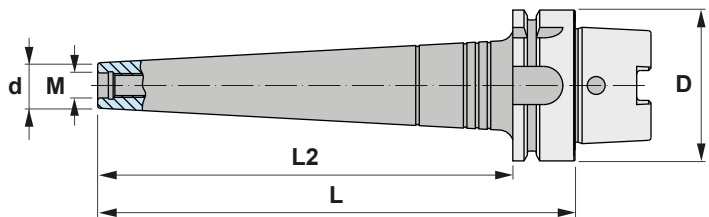

## A16.315IK

Reference Bezeichnung	HSK	L	d	M	L2	D	
A16.315.063.10/200IK	63	200	18	M10	174	63	1,290
A16.315.063.10/250IK	63	250	18	M10	224	63	1,500
A16.315.063.12/200IK	63	200	21	M12	174	63	1,340
A16.315.063.12/250IK	63	250	21	M12	224	63	1,550
A16.315.063.16/250IK	63	250	29	M16	224	63	2,130
A16.315.100.12/300IK	100	300	21	M12	271	100	3,580
A16.315.100.16/300IK	100	300	29	M16	271	100	4,400





**Characteristics:**  
Milling cutter arbors for screw-on  
type milling cutters.  
DIN 69893-1 / HSK Form A.

**Eigenschaften:**  
Spannfutter für Einschraubfräser.  
DIN 69893-1 / HSK Form A.

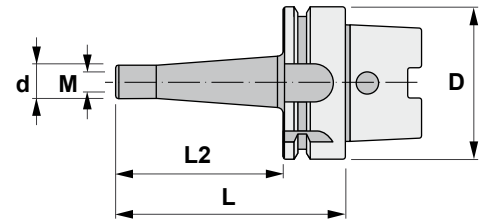

## 16.315

Reference Bezeichnung	HSK	L	d	M	L2	D	
16.315.063.10/050	63	76	18	10	50	63	0,760
16.315.063.10/100	63	126	18	10	100	63	1,020
16.315.063.12/050	63	76	21	12	50	63	0,780
16.315.063.12/100	63	126	21	12	100	63	1,070
16.315.063.16/050	63	76	29	16	50	63	0,900
16.315.063.16/100	63	126	29	16	100	63	1,210
16.315.100.10/100	100	129	18	10	100	100	2,330
16.315.100.10/150	100	179	18	10	150	100	2,510
16.315.100.12/100	100	129	21	12	100	100	2,360
16.315.100.12/150	100	179	21	12	150	100	2,560
16.315.100.16/100	100	129	29	16	100	100	2,440
16.315.100.16/150	100	179	29	16	150	100	2,710





**Characteristics:**

Collet chucks for DIN 6499 (ER) collets. DIN 69893-1 / HSK Form A

For tools with cylindrical shank DIN 1835-B.

\* Ball bearing nut, see page: I221

**\* SUPPLIED WITHOUT WRENCH**

**Eigenschaften:**

Spannzangenfutter für Spannzangen DIN 6499 (ER). DIN 69893-1 / HSK Form A

Für Werkzeuge mit zylindrischem Schaft DIN 1835-B.

\* Für Kugellager-Mutter, siehe Seite: I221

**\* LIEFERUNG OHNE SCHLÜSSEL**

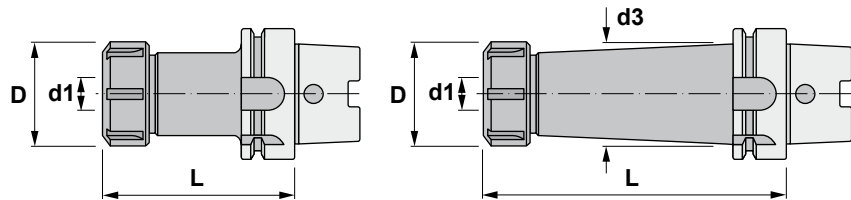

## 16.453

Reference Bezeichnung	HSK		L	d1	D	d3			
16.453.063.16	63	ER16	100	0,5-10	32	-	45316	50216	0,910
16.453.063.16/160	63	ER16	160	0,5-10	32	32	45316	50216	1,050
16.453.063.20	63	ER20	100	1-13	35	-	45320	50220	1,020
16.453.063.20/160	63	ER20	160	1-13	35	35	45320	50220	1,490
16.453.063.25	63	ER25	100	1-16	42	-	45325	50225	1,260
16.453.063.25/160	63	ER25	160	1-16	42	42	45325	50225	1,940
16.453.063.32	63	ER32	100	2-20	50	-	45332	50232	1,630
16.453.063.32/160	63	ER32	160	2-20	50	50	45332	50232	2,720
16.453.063.40	63	ER40	100	3-30	63	-	45340	50240	2,220
16.453.063.40/160	63	ER40	160	3-30	63	-	45340	50240	3,140
16.453.100.25	100	ER25	100	1-16	42	-	45325	50225	2,710
16.453.100.25/160	100	ER25	160	1-16	42	42	45325	50225	3,370
16.453.100.32	100	ER32	100	2-20	50	-	45332	50232	3,070
16.453.100.32/160	100	ER32	160	2-20	50	50	45332	50232	4,000
16.453.100.40	100	ER40	100	3-30	63	-	45340	50240	3,640
16.453.100.40/160	100	ER40	160	3-30	63	63	45340	50240	5,110

**ERXX**

I210-212

Reference / Bezeichnung

ERXX



**40.453..**

I180

Reference / Bezeichnung

40.453..



**ERCXX**

I215-216

Reference / Bezeichnung

ERCXX



**40.455..**

I181

Reference / Bezeichnung

40.455..



**ERTXX**

I217-218

Reference / Bezeichnung

ERTXX





**Characteristics:**

Long collet chucks for DIN 6499 (ER) collets. DIN 69893-1 / HSK Form A  
For tools with cylindrical shank.  
With "mini" collet nut.

**\* SUPPLIED WITHOUT WRENCH**



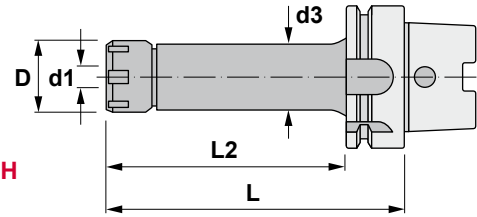

**Eigenschaften:**

Lange Spannzangenfutter für Spannzangen DIN 6499 (ER).  
DIN 69893-1 / HSK Form A  
Für Werkzeuge mit zylindrischem Schaft.  
Mit "Mini"-Spannmutter.

**\* LIEFERUNG OHNE SCHLÜSSEL**



## 16.455

Reference Bezeichnung	HSK		L	d1	D	L2	d3				
16.455.063.16	63	ER16	100	0,5-10	22	-	-	45516	50916	19210	0,880
16.455.063.16/160	63	ER16	160	0,5-10	22	100	30	45516	50916	19210	1,040
16.455.063.20/160	63	ER20	160	1-13	28	100	30	45520	50920	19212	1,260
16.455.063.25/160	63	ER25	160	1-16	35	100	30	45525	50925	19216	1,640

### ERXX

 I210-212

Ref. / Bez.      Accessories / Zubehör

ERXX      Collets with double slot DIN 6499 - Form B (ER)  
Spannzangen mit Doppelnut DIN 6499 - Form B (ER)



### ERCXX

 I215-216

Ref. / Bez.      Accessories / Zubehör

ERCXX      Sealed collets DIN 6499 (ER)  
Abgedichtete Spannzangen DIN 6499 (ER)



### ERTXX

 I217-218

Ref. / Bez.      Accessories / Zubehör

ERTXX      Collets DIN 6499 - Form Mexin (ER)  
Spannzangen DIN 6499 - Form Mexin (ER)





Characteristics:  
Blank adaptors.  
DIN 69893-1 / HSK Form A

Eigenschaften:  
Rohlinge.  
DIN 69893-1 / HSK Form A

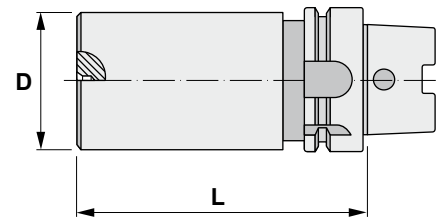

## 16.470

Reference Bezeichnung	HSK	D	L	
16.470.063.063/250	63	63	250	6,100
16.470.063.080/250	63	80	250	10,160
16.470.100.063/200	100	63	200	7,010
16.470.100.080/250	100	80	250	11,980
16.470.100.090/300	100	90	300	17,010





Characteristics:  
Test arbors.  
DIN 69893-1 / HSK Form A

Eigenschaften:  
Prüfdorne.  
DIN 69893-1 / HSK Form A

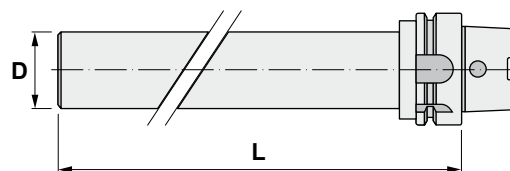

## 16.999

Reference Bezeichnung	HSK	L	D	 Kg
16.999.063	63	300	40	3,470
16.999.100	100	300	50	6,760



**1 TYPE / TYP**

A16.160IK 	A16.160 	16.160 	16.180 	16.210 
16.215 	16.296 	16.300 	16.305 	A16.315IK 
16.315 	16.453 	16.455 	16.470 	

**2 DIMENSION / ABMESSUNGEN**

<b>63</b>	<b>100</b>
-----------	------------

**3 LENGTH / LÄNGE (L)**

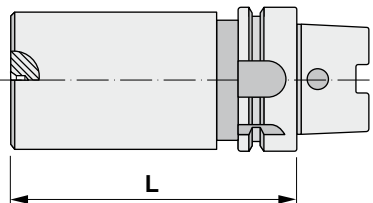
	<hr/> <hr/> <hr/> <hr/> <hr/>
---	-------------------------------

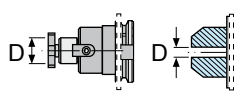
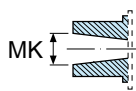
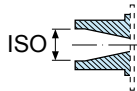
<p>Ø DIAMETER / DURCHMESSER</p> 	<p>MK</p> 	<p>ISO</p> 	<p>COLLET SPANNZANGEN</p>

**NOTES / BEMERKUNGEN:**

---



---



---



---



