



BORING HEADS CAPÇALS DE MANDRINAR

Code system Sistema de codificació	I148-151
Technical information Informació tècnica	I152
Applications index Índex d'aplicacions	I153
Adjustable boring bars Barres de mandrinar ajustables	I154
Boring heads Capçals de mandrinar	I155-163
Arbors for boring heads Cons per a capçals de mandrinar	I164-170
Sets Sets	I171
Special tool request Formulari eines especials	I172



Code system - Boring heads Sistema de codificació - Capçals de mandrinar

63	12	2430
1	2	3

1 Holder style Tipus de capçal

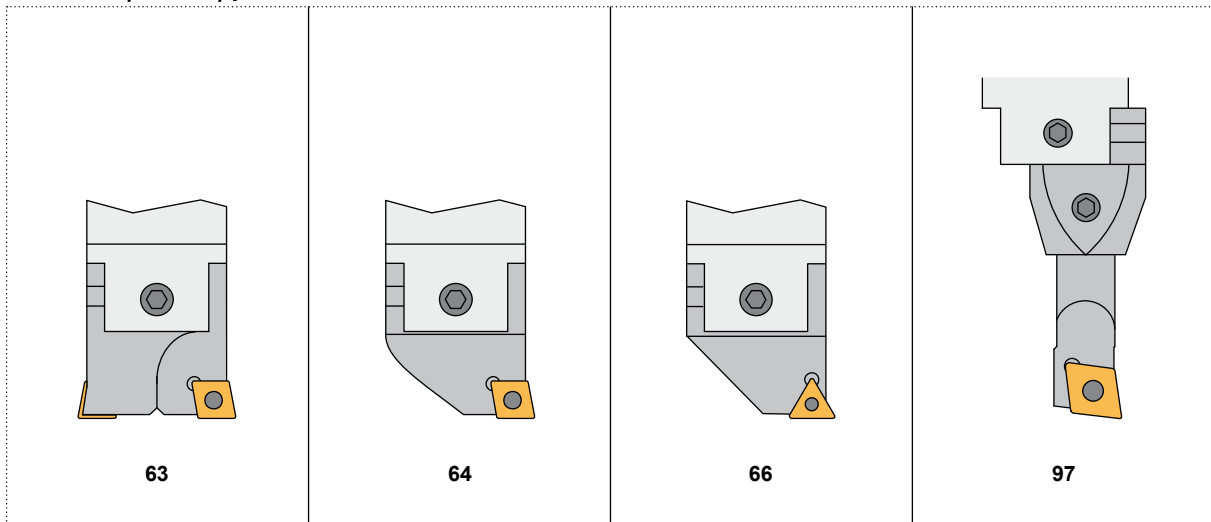

2 Adapter size, mm. Mides de l'adaptador, mm.

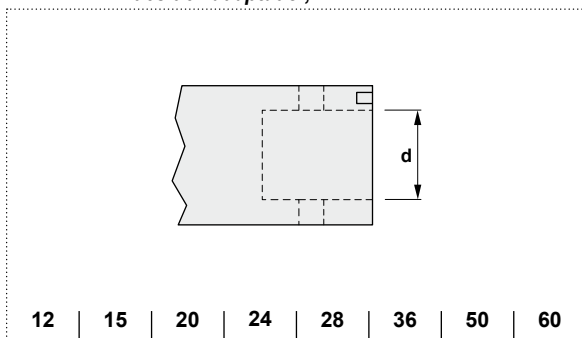

3 Diameter (Min.-Max.), mm. Diàmetre (Min.-Max.), mm.

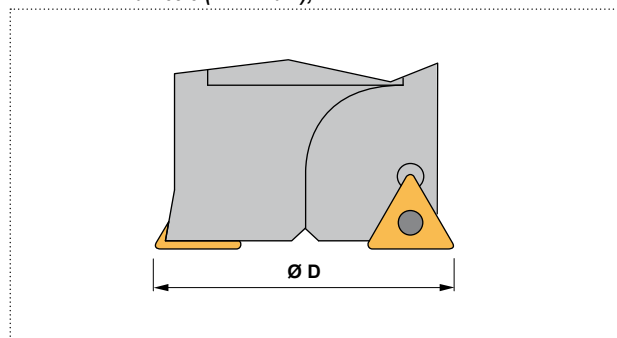

Code system - Arbors for boring heads Sistema de codificació - Cons per a capçals de mandrinar

10 700 30 12 / 100

1 2 3 4 5

1 Machining center Model

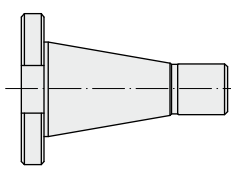
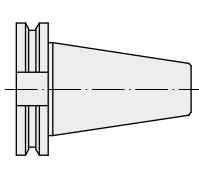
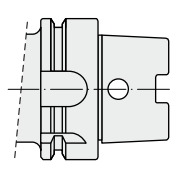
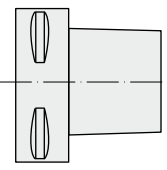
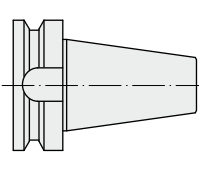
 10	DIN 2080	 11	ISO 7388	 16	DIN 69871/A	HSK	 18	ISO 26623-1	 20	JIS B 6339-BT	DIN 69893-1
PSC	ISO 26623-1	ISO	JIS B 6339-BT								

2 Adapter type Tipus de con

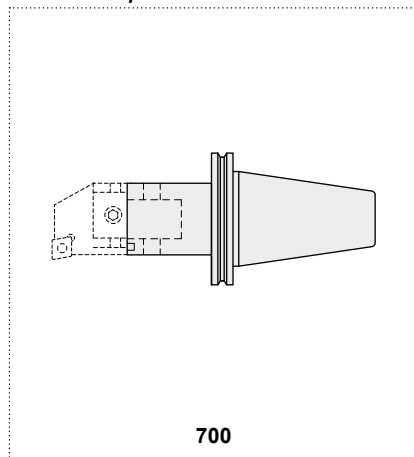

3 Connection dimension Mides del con

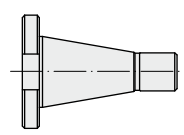
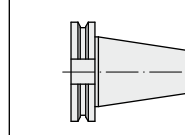
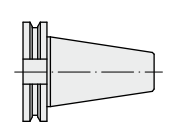
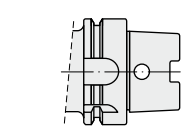
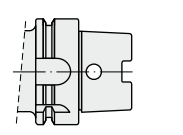
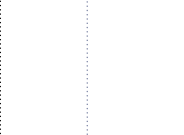
 30	ISO 30	 40	DIN 2080	 50	ISO 7388	 63	DIN 69871/A	 80	HSK	 100	DIN 69893-1
ISO 30	ISO 40	ISO 50		7388 30	7388 40	7388 50			50	63	100
PSC							ISO 26623-1		ISO	JIS B 6339-BT	
									BT 30	BT 40	BT 50
32	40	50	63	80	100				30	40	50

4 Adapter size, mm. Mides de l'adaptador, mm.

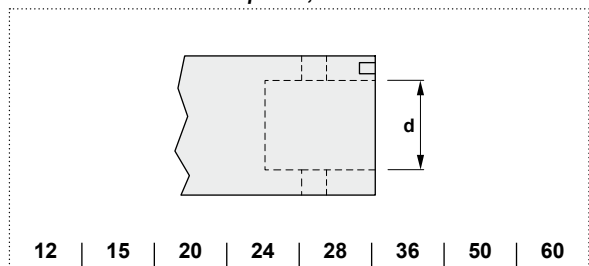

5 Adapter length, mm. Llargada de l'adaptador, mm.

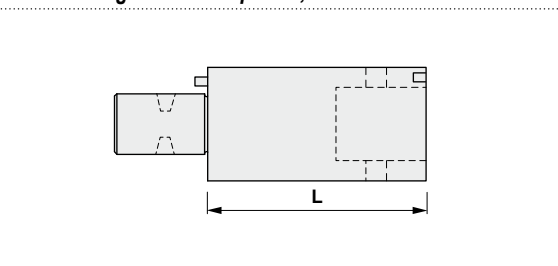

Code system - Arbors for boring heads Sistema de codificació - Cons per a capçals de mandrinar

60 **12** **12** / **20**
1 2 3 4

1 Adapter type
Tipus de con

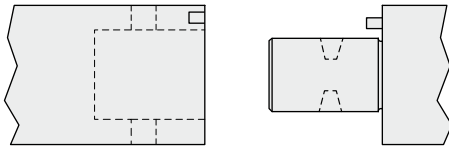

60

2 Adapter size, mm.
Mides de l'adaptador, mm.

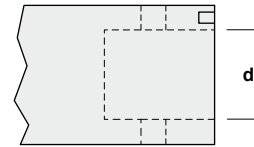

12 | 15 | 20 | 24 | 28 | 36 | 50 | 60

3 Shank diameter, mm.
Diàmetre del mànec, mm.

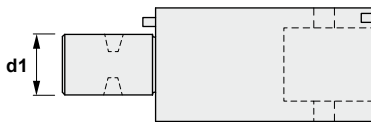

4 Adapter length, mm.
Llargada de l'adaptador, mm.

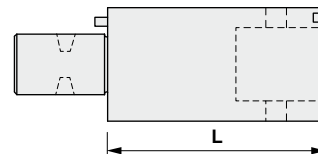

60 **62** **12**
1 2 3

1 Adapter type
Tipus de con

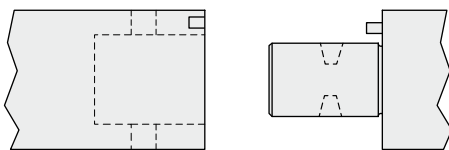

60

2 Shank diameter
Diàmetre del mànec

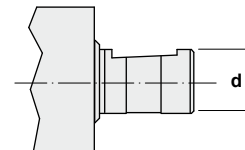

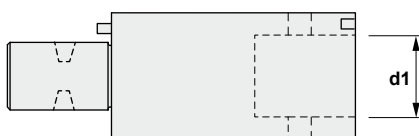

62 | 63 | 64

3 Adapter size, mm.
Mides de l'adaptador, mm.

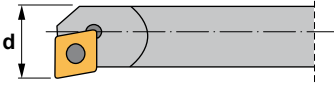
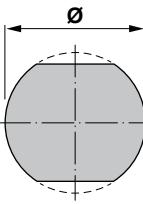
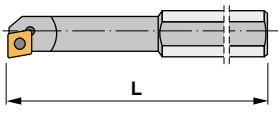
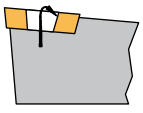

Code system - Tools for boring heads Sistema de codificació - Barres per a capçals de mandrinar

S	08	16	F	S	C	L	C	R	06
1	2	3	4	5	6	7	8	9	10

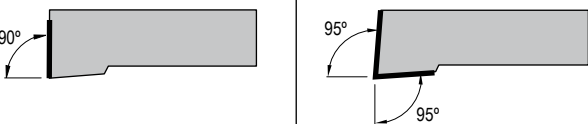
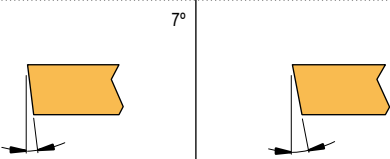
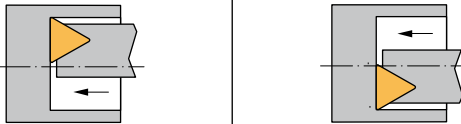
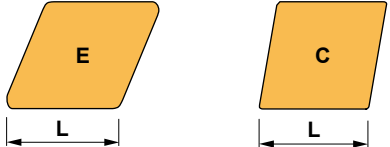
<p>1 <i>Type of bar</i> <i>Tipus de mànec</i></p> <p>A Steel shank with coolant hole Mànec d'acer amb refrigeració interior</p> <hr/> <p>S Steel shank Mànec d'acer</p>	<p>2 <i>Minimum diameter, mm.</i> <i>Diàmetre mínim, mm.</i></p> 	<p>3 <i>Bar diameter, mm.</i> <i>Diàmetre del mànec, mm.</i></p> 														
<p>4 <i>Bar length, mm.</i> <i>Llargada del mànec, mm.</i></p>  <table border="1" data-bbox="199 1265 566 1321"> <tr> <td>70</td> <td>80</td> <td>90</td> <td>100</td> <td>110</td> <td>115</td> <td>Special Especial</td> </tr> <tr> <td>E</td> <td>F</td> <td>G</td> <td>H</td> <td>I</td> <td>J</td> <td>X</td> </tr> </table>	70	80	90	100	110	115	Special Especial	E	F	G	H	I	J	X	<p>5 <i>Clamping method of insert</i> <i>Tipus de fixació de la plaqueta</i></p>  <p>S</p>	<p>6 <i>Insert shape</i> <i>Forma de la plaqueta</i></p>  <p>C T</p>
70	80	90	100	110	115	Special Especial										
E	F	G	H	I	J	X										
<p>7 <i>Holder style</i> <i>Tipus d'eina</i></p>  <p>F L</p>	<p>8 <i>Clearance angle of insert</i> <i>Angle d'incidència de la plaqueta</i></p>  <p>C P</p>															
<p>9 <i>Hand</i> <i>Direcció de tall</i></p>  <p>L R</p>	<p>10 <i>Cutting edge length, mm.</i> <i>Llargada de l'aresta de tall, mm.</i></p>  <p>E C</p>															



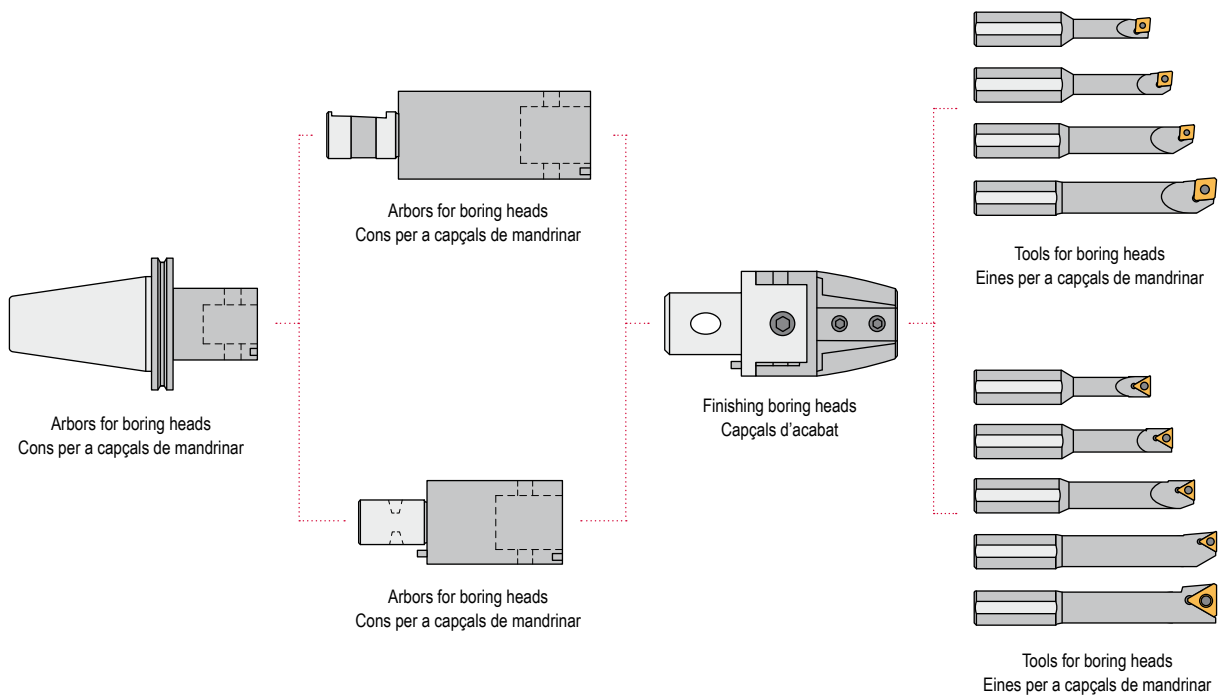
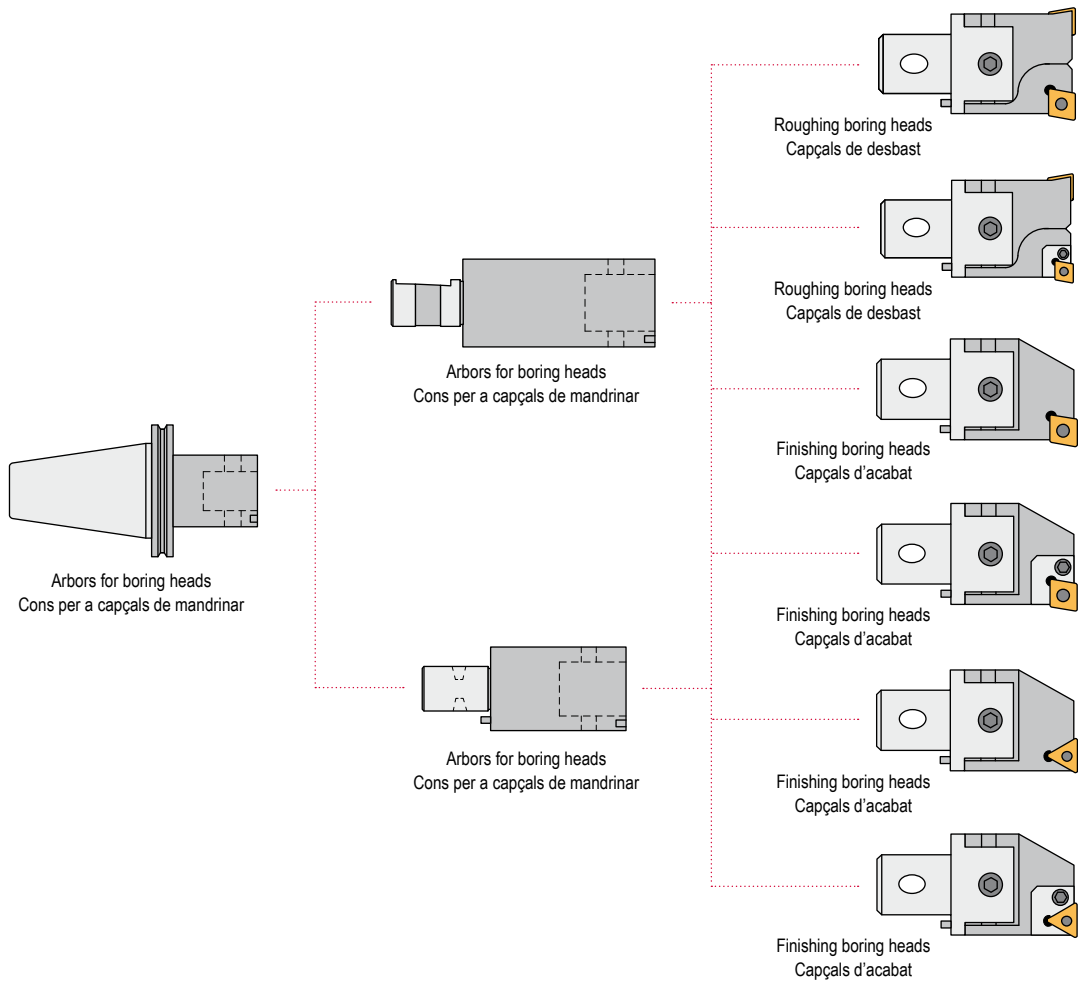

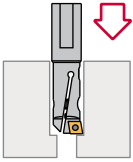

Adjustable boring bars
Barres de mandrinar ajustables

<p>6114.0/27</p>  <p>Page Pàgina 1154</p>				
---------------------------------------------------------------------------------------------------------------------------------------	--	--	--	--

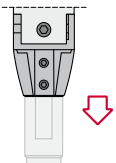
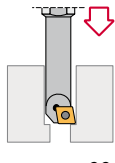
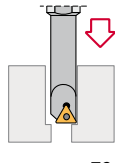
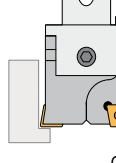
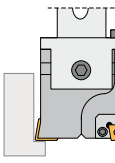
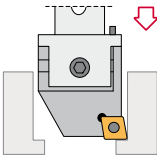
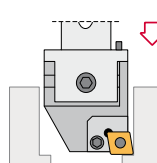
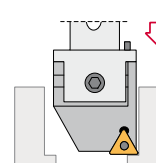
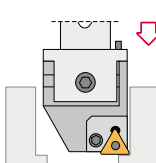
Boring heads
Capçals de mandrinar

<p>97.15/24</p>  <p>Page Pàgina 1155</p>	<p>SCLC</p>  <p>Page Pàgina 1156</p> <p>CC.. 0602.. CC.. 09T3..</p>	<p>STFC</p>  <p>Page Pàgina 1157</p> <p>TC.. 0902.. TC.. 16T3..</p>	<p>63.12/28</p>  <p>Page Pàgina 1158</p> <p>CC.. 0602.. CC.. 1204..</p>	<p>63.36/60</p>  <p>Page Pàgina 1159</p> <p>CC.. 1204..</p>
<p>64.12/28</p>  <p>Page Pàgina 1160</p> <p>CC.. 0602.. CC.. 1204..</p>	<p>64.36/60</p>  <p>Page Pàgina 1161</p> <p>CC.. 1204..</p>	<p>66.20/28</p>  <p>Page Pàgina 1162</p> <p>TC.. 16T3..</p>	<p>66.36/60</p>  <p>Page Pàgina 1163</p> <p>TC.. 16T3..</p>	

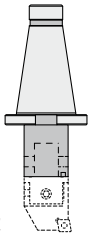
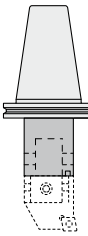
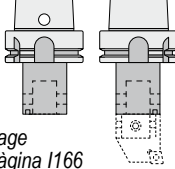
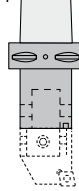
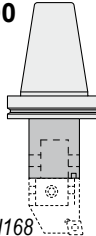
Arbors for boring heads
Cons per a capçals de mandrinar

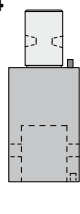
<p>10.700 DIN 2080</p>  <p>Page Pàgina 1164</p>	<p>11.700 DIN 69871-A</p>  <p>Page Pàgina 1165</p>	<p>16.700 DIN 69893-1 / FORM A</p>  <p>Page Pàgina 1166</p>	<p>18.700 PSC ISO 26623-1</p>  <p>Page Pàgina 1167</p>	<p>20.700 MAS BT</p>  <p>Page Pàgina 1168</p>
<p>60.62/64</p>  <p>Page Pàgina 1169</p>	<p>60.12/24</p>  <p>Page Pàgina 1170</p>			



Characteristics:
Adjustable boring bars.

Característiques:
Barra de mandrinar ajustable.

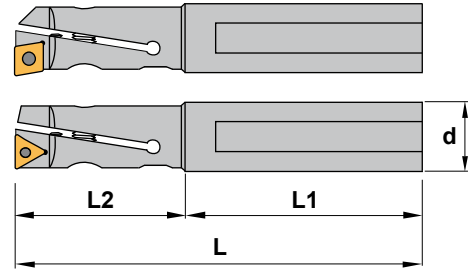
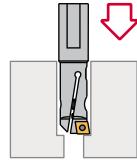

6114.0₂₇

Reference Referència	L	L1	L2	d	Dmin	Dmax	Insert size Mida plaqueta	
6114.07.012	105	70	35	12	12	15	CC.. 0602..	0,080
6114.07.015	110	60	50	16	15	20	CC.. 0602..	0,110
6114.07.020	120	60	60	20	20	25	TC.. 1102..	0,160
6114.07.025	140	70	70	25	25	30	TC.. 16T3..	0,280
6114.07.030	160	70	90	25	30	35	TC.. 16T3..	0,360
6114.27.012	175	145	30	12	12	15	CC.. 0602..	0,150
6114.27.015	175	125	50	16	15	20	CC.. 0602..	0,260
6114.27.020	200	140	60	20	20	25	TC.. 1102..	0,430
6114.27.025	200	130	70	25	25	30	TC.. 16T3..	0,550
6114.27.030	200	110	90	25	30	35	TC.. 16T3..	0,500

Reference Referència								Nm
6114.07.012	1550	1503	1425	-	5015	5520	5507	0.9
6114.07.015	1261	1534	1425	1534	5002	5525	5507	0.9
6114.07.020	1182	1515	1225	1515	5025	5525	5507	0.9
6114.07.025	1908	1517	1240	1517	5025 / 5005	-	5515	3.0
6114.07.030	1910	1517	1240	1518	5025 / 5006	-	5515	3.0
6114.27.012	1550	1503	1425	-	5015	5520	5507	0.9
6114.27.015	1261	1534	1425	1534	5002	5525	5507	0.9
6114.27.020	1182	1515	1225	1515	5025	5525	5507	0.9
6114.27.025	1908	1517	1240	1517	5025 / 5005	-	5515	3.0
6114.27.030	1910	1517	1240	1518	5025 / 5006	-	5515	3.0

CC..

80° rhombic positive inserts with 7° clearance. F21
Plaquetes ròmbiques positives 80° amb 7° incidència.

Reference / Ref.	l	s	d
CC.. 0602..	6,45	2,38	6,35

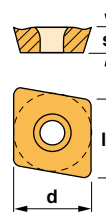

CCGT-AL



CCMT



CCMW



TC..

Triangular positive inserts with 7° clearance. F21
Plaquetes triangulars positives amb 7° incidència.

Reference / Ref.	l	s	d
TC.. 0902..	9,62	2,38	5,55
TC.. 16T3..	16,50	3,97	9,52

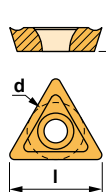

TCGT-AL



TCMT-39



TCMW





Characteristics:
Finishing boring heads.
With graduated dial.
Read-out precision 0,01 mm Ø.

Característiques:
Capçal d'acabat.
Selector graduat, lectura amb
precisió de 0,01 mm Ø.

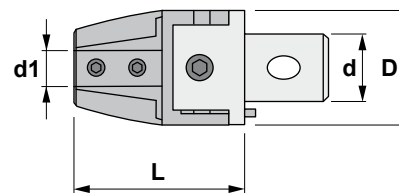

97.15/24

Reference Referència	D	L	d	d1	Dmin	Dmax	
97.15.08	27	50	15	8	10	21	0,170
97.20.08	32	58	20	8	10	21	0,280
97.20.10	32	58	20	10	13	25	0,290
97.24.10	42	70	24	10	13	29	0,650
97.24.12	42	70	24	12	16	34	0,620
97.24.16	42	70	24	16	20	38	0,600

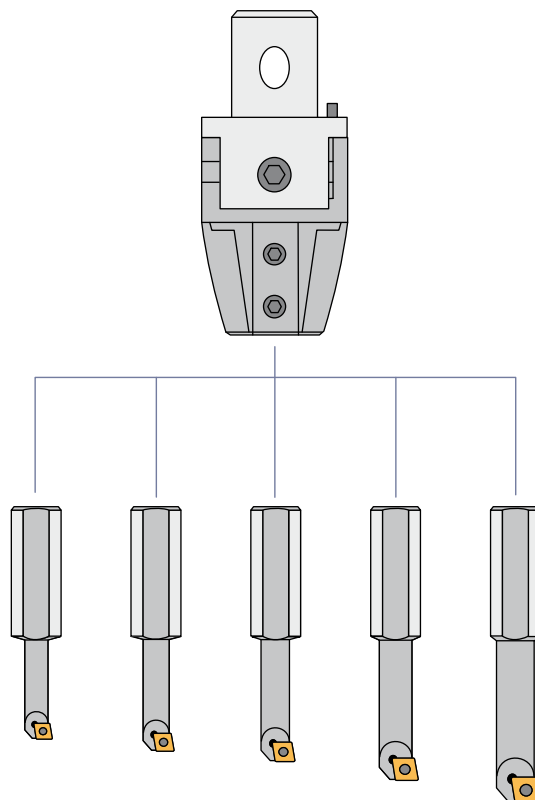

SCLC / STFC



Characteristics:
Tool for boring heads equipped with rhombic positive insert (angle 80°).
The center screw ensures good rigidity and chip flow.

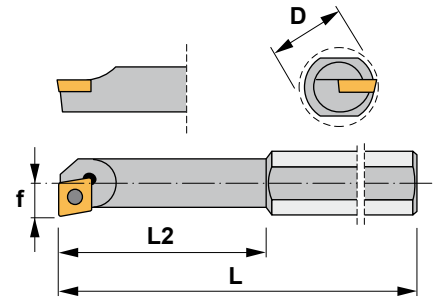

Característiques:
Eina per a capçals de mandrinar equipada amb plaqueta ròmbica positiva (angle 80°).
El cargol central assegura una bona rigidesa i evacuació de ferritges.

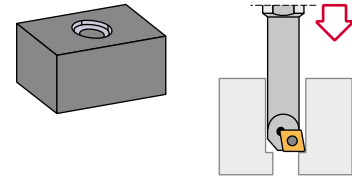

SCLC

Reference Referència	D	L	L2	f	Bore range Diàmetre forat min max		Insert size Mida plaqueta	Kg
S0816F SCLC R 06	16	80	35	4	10	28	CC.. 0602..	0,070
S1016G SCLC R 06	16	90	45	6	13	31	CC.. 0602..	0,100
S1216H SCLC R 06	16	100	57	7	16	34	CC.. 0602..	0,100
S1616I SCLC R 09	16	110	73	9	20	38	CC.. 09T3..	0,150

Reference Referència			Nm	
S0816F SCLC R 06		1425	5507	0.9
S1016G SCLC R 06		1425	5507	0.9
S1216H SCLC R 06		1425	5507	0.9
S1616I SCLC R 09		1440	5515	3.0

CC.. 80° rhombic positive inserts with 7° clearance. F12
Plaquetes ròmbiques positives 80° amb 7° incidència.

Reference / Ref.	l	s	d
CC.. 0602..	6,45	2,38	6,35
CC.. 09T3..	9,65	3,97	9,52

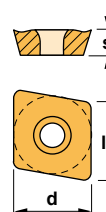

CCGT-AL



CCMT



CCMW





Characteristics:
Tool for boring heads equipped with triangular positive insert.
The center screw ensures good rigidity and chip flow.

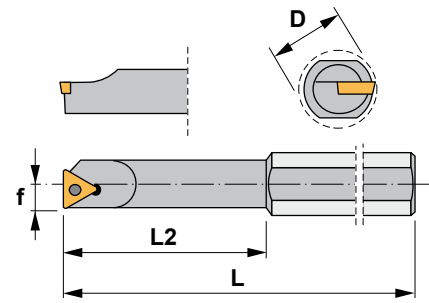

Característiques:
Eina per a capçals de mandrinar equipada amb plaqueta triangular positiva.
El cargol central assegura una bona rigidesa i evacuació de ferritges.

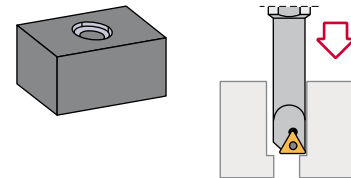

STFC

Reference Referència	D	L	L2	f	Bore range Diàmetre forat min max		Insert size Mida plaqueta	kg
S0816F STFC R 09	16	80	35	5	10	28	TC.. 0902..	0,090
S1016G STFC R 09	16	90	45	6	13	31	TC.. 0902..	0,100
S1216H STFC R 09	16	100	57	7	16	34	TC.. 0902..	0,100
S1616I STFC R 09	16	110	73	9	20	38	TC.. 0902..	0,100
S1616I STFC R 16	16	110	73	11	20	38	TC.. 16T3..	0,150

Reference Referència			Nm
S0816F STFC R 09	1222	5506	0.6
S1016G STFC R 09	1222	5506	0.6
S1216H STFC R 09	1222	5506	0.6
S1616I STFC R 09	1222	5506	0.6
S1616I STFC R 16	1425	5515	3.0

TC..				Triangular positive inserts with 7° clearance. F21		TCGT-AL		TCMT-39	
Reference / Ref.	l	s	d						
TC.. 0902..	9,62	2,38	5,55						
TC.. 16T3..	16,50	3,97	9,52						



Characteristics:
Roughing boring heads.

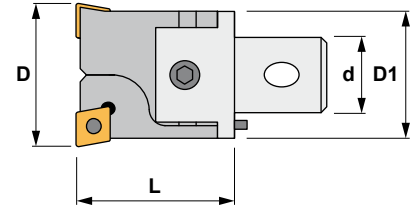



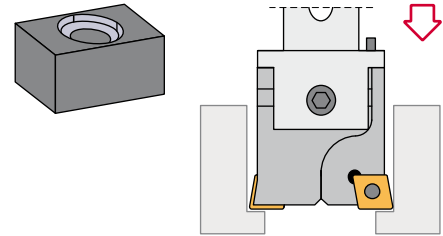

Característiques:
Capçal de desbast.



63.12/28

Reference Referència	D1	L	d	Dmin	Dmax	Insert size Mida plaqueta	
63.12.2430	22	34	12	24	30	CC.. 0602..	0,075
63.15.2940	27	42	15	29	40	CC.. 09T3..	0,150
63.20.3950	32	45	20	39	50	CC.. 09T3..	0,250
63.24.4965	42	56	24	49	65	CC.. 1204..	0,500
63.28.6382	54	56	28	63	82	CC.. 1204..	1,000

Reference Referència					Nm
63.12.2430	1425	5607	5003	5002	0.9
63.15.2940	1240	5615	5004	5002	3.0
63.20.3950	1240	5615	5004	5025	3.0
63.24.4965	1250	5620	5005	5003	4.0
63.28.6382	1250	5620	5006	5003	4.0

CC.. 80° rhombic positive inserts with 7° clearance.  F12
Plaquetes ròmbiques positives 80° amb 7° incidència.

Reference / Ref.	l	s	d
CC.. 0602..	6,45	2,38	6,35
CC.. 09T3..	9,65	3,97	9,52
CC.. 1204..	12,90	4,76	12,70

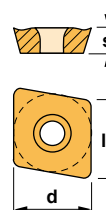

CCGT-AL



CCMT



CCMW





Characteristics:
Roughing boring heads.

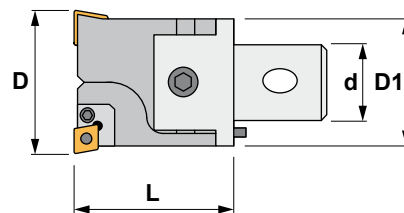

Característiques:
Capçal de desbast.

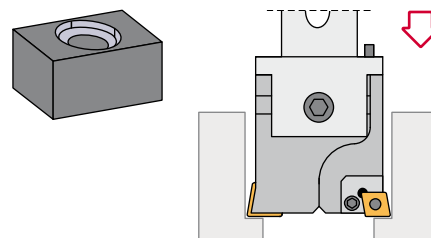

63.36/60

Reference Referència	D1	L	d	Dmin	Dmax	Insert size Mida plaqueta	Kg
63.36.080102	68	86	36	80	102	CC.. 1204..	2,200
63.50.100125	85	100	50	100	125	CC.. 1204..	4,000
63.60.125160	110	100	60	125	160	CC.. 1204..	6,550
63.60.160220	145	100	60	160	220	CC.. 1204..	8,700

Reference Referència						Nm
63.36.080102	1250	5620	5508	5004	6412	4.0
63.50.100125	1250	5620	5508	5005	6412	4.0
63.60.125160	1250	5620	5508	5005	6412	4.0
63.60.160220	1250	5620	5508	5005	6412	4.0

CC..

80° rhombic positive inserts with 7° clearance. F12
Plaquetes ròmbiques positives 80° amb 7° incidència.

Reference / Ref.	l	s	d
CC.. 1204..	12,90	4,76	12,70

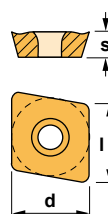

CCGT-AL



CCMT



CCMW





Characteristics:
Finishing boring heads.
With graduated dial.
Read-out precision 0,01 mm Ø.

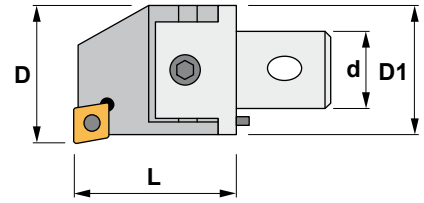

Característiques:
Característiques:
Capçal d'acabat.
Selector graduat, lectura amb
precisió de 0,01 mm Ø.

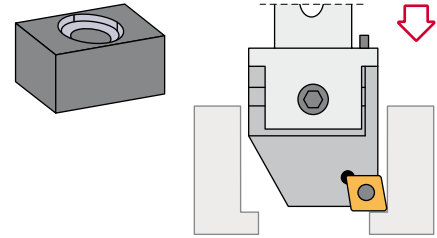

64.12/28

Reference Referència	D1	L	d	Dmin	Dmax	Insert size Mida plaqueta	kg
64.12.2430	22	34	12	24	30	CC.. 0602..	0,075
64.15.2940	27	42	15	29	40	CC.. 09T3..	0,150
64.20.3950	32	45	20	39	50	CC.. 09T3..	0,250
64.24.4965	42	56	24	49	65	CC.. 1204..	0,450
64.28.6382	54	56	28	63	82	CC.. 1204..	0,900

Reference Referència					Nm
64.12.2430	1425	5607	5003	5002	0.9
64.15.2940	1240	5615	5004	5002	3.0
64.20.3950	1240	5615	5004	5025	3.0
64.24.4965	1250	5620	5005	5003	4.0
64.28.6382	1250	5620	5006	5003	4.0

CC.. 80° rhombic positive inserts with 7° clearance. F12
Plaquetes ròmbiques positives 80° amb 7° incidència.

Reference / Ref.	l	s	d
CC.. 0602..	6,45	2,38	6,35
CC.. 09T3..	9,65	3,97	9,52
CC.. 1204..	12,90	4,76	12,70

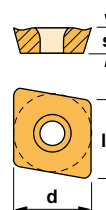

CCGT-AL



CCMT



CCMW





Characteristics:
Finishing boring heads.
With graduated dial.
Read-out precision 0,01 mm Ø.

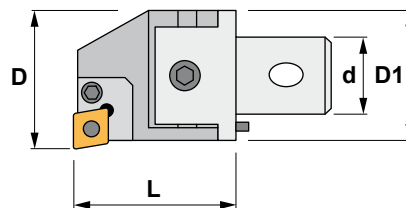

Característiques:
Capçal d'acabat.
Selector graduat, lectura amb
precisió de 0,01 mm Ø.

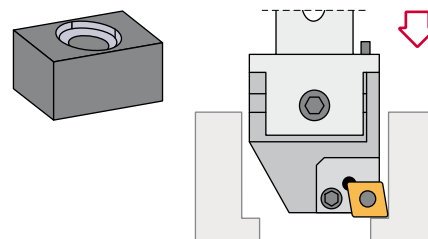

64.36/60

Reference Referència	D1	L	d	Dmin	Dmax	Insert size Mida plaqueta	Kg
64.36.080102	68	86	36	80	102	CC.. 1204..	2,050
64.50.100125	85	100	50	100	125	CC.. 1204..	3,700
64.60.125160	110	100	60	125	160	CC.. 1204..	6,150
64.60.160220	145	100	60	160	220	CC.. 1204..	8,050

Reference Referència						Nm
64.36.080102	1250	5620	5508	5004	6412	4.0
64.50.100125	1250	5620	5508	5005	6412	4.0
64.60.125160	1250	5620	5508	5005	6412	4.0
64.60.160220	1250	5620	5508	5005	6412	4.0

CC.. 80° rhombic positive inserts with 7° clearance. F12
Plaquetes ròmbiques positives 80° amb 7° incidència.

Reference / Ref.	l	s	d
CC.. 1204..	12,90	4,76	12,70

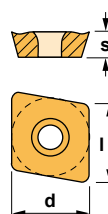

CCGT-AL



CCMT



CCMW





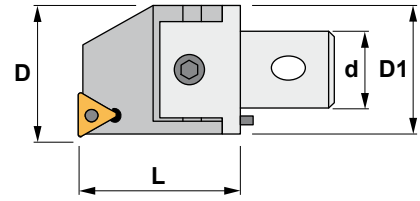

Characteristics:
Finishing boring heads.
With graduated dial.
Read-out precision 0,01 mm Ø.



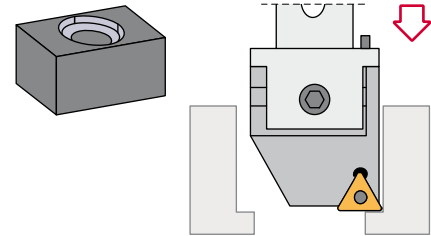



Característiques:
Capçal d'acabat.
Selector graduat, lectura amb
precisió de 0,01 mm Ø.



66.20/28

Reference Referència	D1	L	d	Dmin	Dmax	Insert size Mida plaqueta	
66.20.3950	32	45	20	39	50	TC.. 16T3..	0,250
66.24.4965	42	56	24	49	65	TC.. 16T3..	0,450
66.28.6382	54	66	28	63	82	TC.. 16T3..	0,900

Reference Referència					Nm
66.20.3950	1240	5615	5004	5025	3.0
66.24.4965	1240	5615	5005	5003	4.0
66.28.6382	1240	5615	5006	5003	4.0

TC..

Triangular positive inserts with 7° clearance.  F21
Plaquetes triangulars positives amb 7° incidència.

Reference / Ref.	l	s	d
TC.. 16T3..	16,50	3,97	9,52

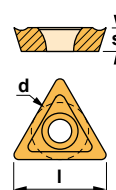

TCGT-AL



TCMT-39



TCMW





Characteristics:
Finishing boring heads.
With graduated dial.
Read-out precision 0,01 mm Ø.

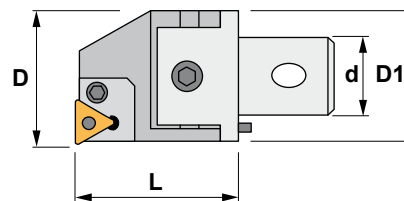

Característiques:
Capçal d'acabat.
Selector graduat, lectura amb
precisió de 0,01 mm Ø.

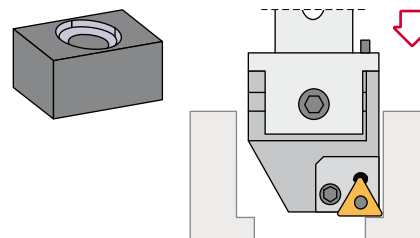

66.36/60

Reference Referència	D1	L	d	Dmin	Dmax	Insert size Mida plaqueta	KG
66.36.080102	68	86	36	80	102	TC.. 16T3..	2,050
66.50.100125	85	100	50	100	125	TC.. 16T3..	3,700
66.60.125160	110	100	60	125	160	TC.. 16T3..	6,150
66.60.160220	145	100	60	160	220	TC.. 16T3..	8,050

Reference Referència						Nm
66.36.080102	1240	5615	5508	5004	6416	4.0
66.50.100125	1240	5615	5508	5005	6416	4.0
66.60.125160	1240	5615	5508	5005	6416	4.0
66.60.160220	1240	5615	5508	5005	6416	4.0

TC.. Triangular positive inserts with 7° clearance. F21
Plaquetes triangulars positives amb 7° incidència.

Reference / Ref.	l	s	d
TC.. 16T3..	16,50	3,97	9,52

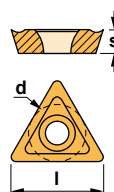

TCGT-AL



TCMT-39



TCMW





Characteristics:
Arbors for boring heads.
DIN 2080

Característiques:
Con per a capçals de mandrinar.
DIN 2080

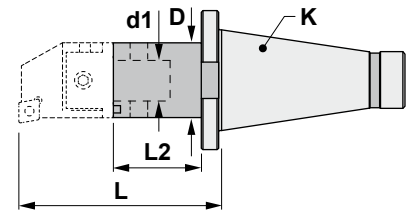

10.700

Reference Referència	K ISO	D	L	L2	d1	
10.700.30.12/100	30	22	113	79	12	0,450
10.700.30.15/100	30	27	113	100	15	0,550
10.700.30.20/100	30	32	113	68	20	0,600
10.700.40.12/100	40	22	115	81	12	0,950
10.700.40.15/100	40	27	115	73	15	1,050
10.700.40.20/100	40	32	115	70	20	1,100
10.700.40.24/160	40	42	175	119	24	1,850
10.700.40.28/160	40	54	175	109	28	2,300
10.700.40.36/160	40	68	176	90	36	2,500
10.700.50.12/100	50	22	119	85	12	2,850
10.700.50.15/100	50	27	119	77	15	2,900
10.700.50.20/130	50	32	149	104	20	3,150
10.700.50.24/160	50	42	179	123	24	3,700
10.700.50.28/160	50	54	179	113	28	4,250
10.700.50.36/200	50	68	220	134	36	5,650
10.700.50.50/200	50	85	281	181	50	6,350
10.700.50.60/260	50	100	281	181	60	11,000



Characteristics:
Arbors for boring heads.
DIN 69871-A

Característiques:
Con per a capçals de mandrinar.
DIN 69871-A

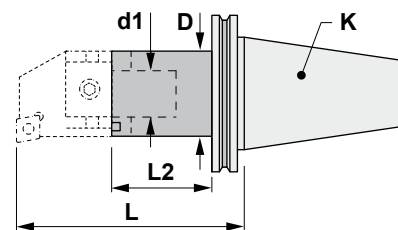

11.700

Reference Referència	K ISO	D	L	L2	d1	 Kg
11.700.40.12/100	40	22	138	104	12	1,200
11.700.40.15/100	40	27	138	96	15	1,250
11.700.40.20/100	40	32	138	93	20	1,500
11.700.40.24/160	40	42	182	126	24	1,900
11.700.40.28/160	40	54	182	116	28	2,300
11.700.40.36/160	40	68	183	97	36	2,600
11.700.50.12/100	50	22	138	104	12	3,350
11.700.50.15/100	50	27	138	96	15	3,400
11.700.50.20/130	50	32	168	123	20	3,600
11.700.50.24/160	50	42	198	142	24	4,200
11.700.50.28/160	50	54	198	132	28	4,700
11.700.50.36/200	50	68	223	137	36	5,650
11.700.50.50/200	50	85	224	124	50	6,200
11.700.50.60/260	50	100	284	184	60	10,850





Characteristics:
Arbors for boring heads.
DIN 69893-1 / Form A

Característiques:
Con per a capçals de mandrinar.
DIN 69893-1 / Forma A

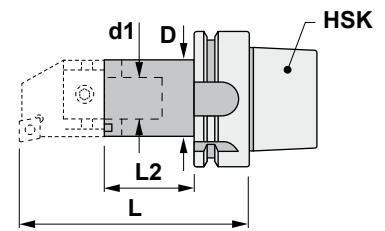
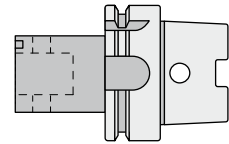

16.700

Reference Referència	HSK	D	L	L2	d1	
16.700.63.12/055	63	22	81	47	12	0,700
16.700.63.12/110	63	22	136	102	12	0,840
16.700.63.15/065	63	27	91	49	15	0,730
16.700.63.15/110	63	27	110	68	15	0,910
16.700.63.20/075	63	32	101	56	20	0,780
16.700.63.20/120	63	32	120	75	20	1,050



Characteristics:
Arbors for boring heads.
PSC ISO 26623-1

Característiques:
Con per a capçals de mandrinar.
PSC ISO 26623-1

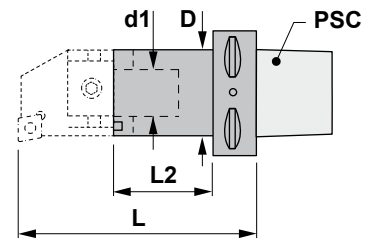

18.700

Reference Referència	PSC	D	L	L2	d1	
18.700.63.12/055	63	22	77	43	12	0,750
18.700.63.12/110	63	22	132	98	12	0,920
18.700.63.15/065	63	27	87	45	15	0,880
18.700.63.15/110	63	27	132	90	15	1,080
18.700.63.20/075	63	32	97	52	20	1,000
18.700.63.20/120	63	32	142	97	20	1,280





Characteristics:
Arbors for boring heads.
MAS BT

Característiques:
Con per a capçals de mandrinar.
MAS BT

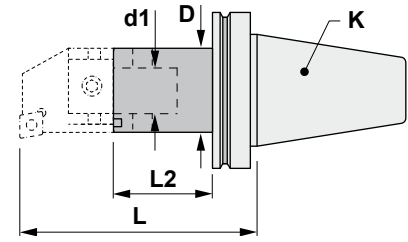

20.700

Reference Referència	K ISO	D	L	L2	d1	
20.700.40.12/100	40	22	130	96	12	1,200
20.700.40.15/100	40	27	130	88	15	1,250
20.700.40.20/100	40	32	130	100	20	1,600
20.700.40.24/160	40	42	190	134	24	2,050
20.700.40.28/160	40	54	190	124	28	2,550
20.700.40.36/160	40	68	181	95	36	2,550
20.700.50.12/100	50	22	141	107	12	3,850
20.700.50.15/100	50	27	141	99	15	3,950
20.700.50.20/130	50	32	171	126	20	4,200
20.700.50.24/160	50	42	201	145	24	5,200
20.700.50.28/160	50	54	201	135	28	5,800
20.700.50.36/200	50	68	242	156	36	6,650
20.700.50.50/200	50	85	242	142	50	7,400
20.700.50.60/260	50	100	302	202	60	12,300



Characteristics:
Extensions DIN 1835 for the
arbors for boring heads.

Característiques:
Extensions DIN 1835 per als
capçals de mandrinar.

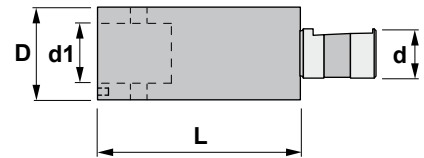

60.62/64

Reference Referència	D	d	L	d1	
60.62.12	22	20	20	12	0,050
60.62.15	27	20	30	15	0,100
60.63.12	22	20	30	12	0,120
60.63.15	27	20	45	15	0,230
60.63.20	32	25	35	20	0,320
60.64.12	22	20	52	12	0,210
60.64.15	27	20	52	15	0,290
60.64.20	32	20	52	20	0,400
60.64.24	42	25	60	24	0,500





Characteristics:
Extensions for the arbors for boring heads.

Característiques:
Extensions per als capçals de mandrinar.

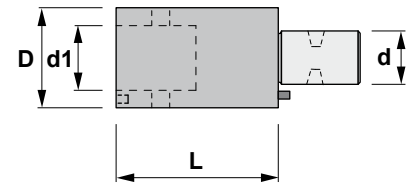

60.12/24

Reference Referència	D	d	L	d1	
60.12.12/20	22	12	20	12	0,050
60.12.12/30	22	12	30	12	0,100
60.15.15/30	27	15	30	15	0,130
60.15.15/45	27	15	45	15	0,190
60.20.20/35	32	20	35	20	0,200
60.20.20/52	32	20	52	20	0,270
60.24.24/40	42	24	40	24	0,400
60.24.24/60	42	24	60	24	0,600



Characteristics:
Set of roughing boring
head and boring bars.

Característiques:
Set de capçal de desbast i
barres de mandrinar.

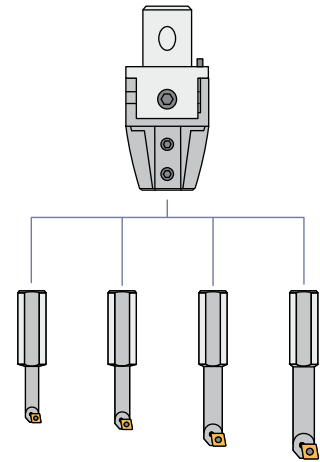

SET-97

Reference Referència	Boring head Capçal de mandrinar	Boring bars Barra de mandrinar	Bore range Diàmetre forat		⚠ KG
			min	max	
SET-97 SCLC	97.24.16	S0816F SCLC R 06	10	28	1,020
		S1016G SCLC R 06	13	31	
		S1216H SCLC R 06	16	34	
		S1616I SCLC R 09	20	38	



Characteristics:
Set of roughing boring
head and boring bars.

Característiques:
Set de capçal de desbast i
barres de mandrinar.

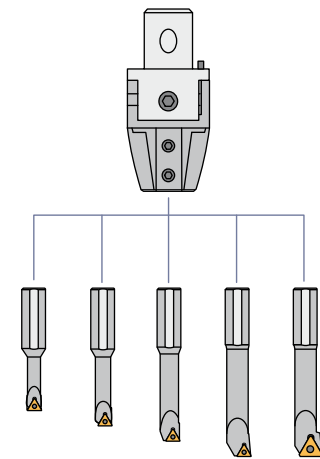

SET-97

Reference Referència	Boring head Capçal de mandrinar	Boring bars Barra de mandrinar	Bore range Diàmetre forat		⚠ KG
			min	max	
SET-97 STFC	97.24.16	S0816F STFC R09	10	28	1,140
		S1016G STFC R 09	13	31	
		S1216H STFC R 09	16	34	
		S1216I STFC R 09	20	38	
		S1616I STFC R 16	20	38	

1 TYPE / MODEL

10.700



11.700



16.700



18.700



20.700



60.62/24



60.12/24



2 DIMENSION / MIDA

ISO

30

40

50

HSK

63

PSC

63

3 LENGTH / LLARGADA (L)

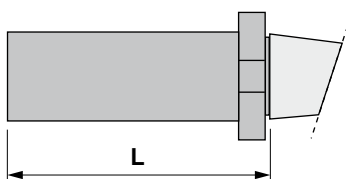

Ø DIAMETER / DIÀMETRE



COLLET
PINÇA

NOTES / ANOTACIONS:
