



DIN 2080

Sistema di codifica Sistema de codificación	I02
Informazione tecnica Información técnica	I03
Indice applicazioni Índice de aplicaciones	I04
Mandrini e adattatori DIN 2080 Conos y adaptadores DIN 2080	I05-24
Richiesta utensile speciale Formulario herramientas especiales	I25



Sistema di codifica / Sistema de codificación

10	160	30	16
1	2	3	4

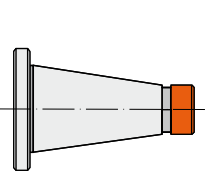
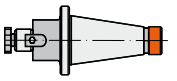
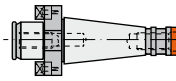
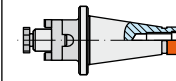
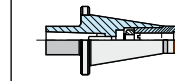
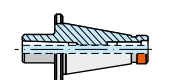
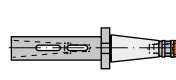
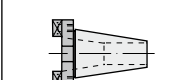
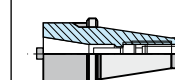
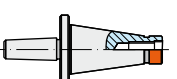
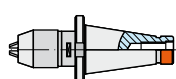
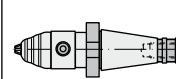
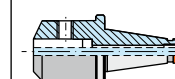
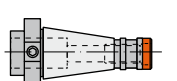
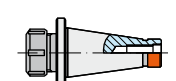
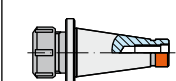
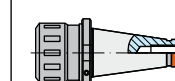
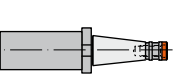
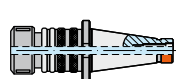
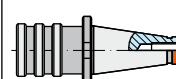
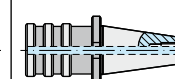
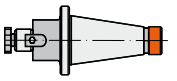
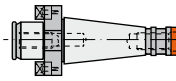
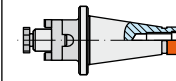
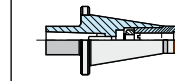
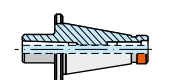
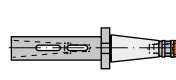
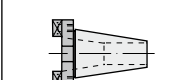
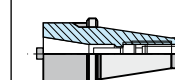
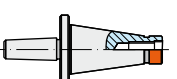
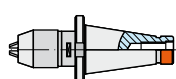
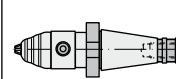
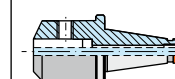
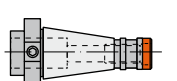
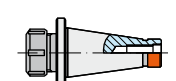
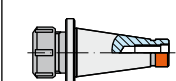
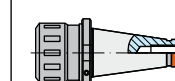
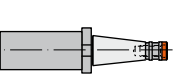
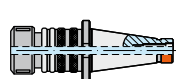
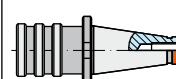
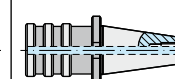
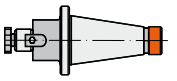
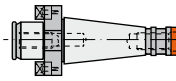
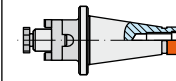
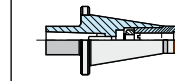
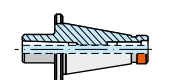
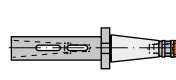
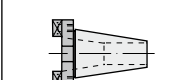
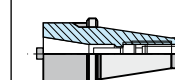
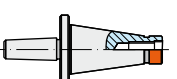
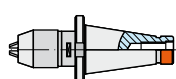
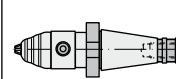
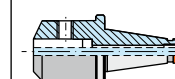
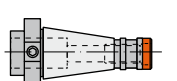
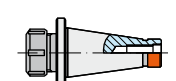
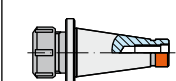
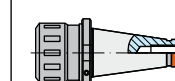
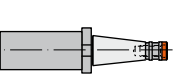
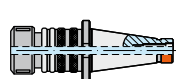
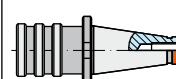
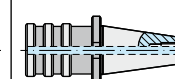
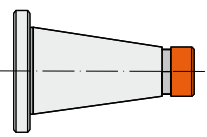
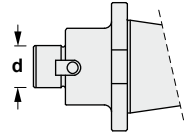
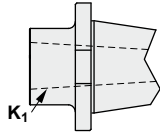
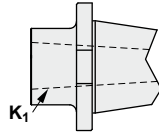
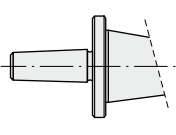
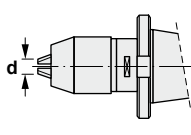
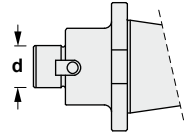
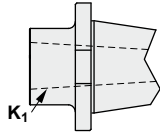
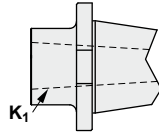
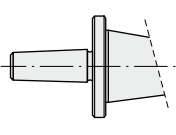
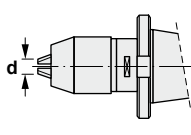
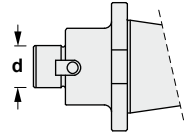
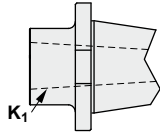
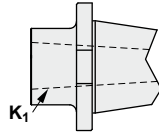
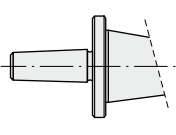
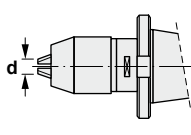
<p>1 <i>Modello</i> <i>Tipo de cono</i></p>  <p style="text-align: center;">10</p>	<p>2 <i>Tipo di mandrino</i> <i>Modelo de cono</i></p> <table border="1" style="width: 100%; text-align: center;"> <tr> <td> 160</td> <td> 165</td> <td> 180</td> <td> 210</td> </tr> <tr> <td> 215</td> <td> 216</td> <td> 220</td> <td> 225</td> </tr> <tr> <td> 290</td> <td> 295</td> <td> 296</td> <td> 300</td> </tr> <tr> <td> 302</td> <td> 353</td> <td> 453</td> <td> 457</td> </tr> <tr> <td> 470</td> <td> 610</td> <td> 620</td> <td> 630</td> </tr> </table>	 160	 165	 180	 210	 215	 216	 220	 225	 290	 295	 296	 300	 302	 353	 453	 457	 470	 610	 620	 630
 160	 165	 180	 210																		
 215	 216	 220	 225																		
 290	 295	 296	 300																		
 302	 353	 453	 457																		
 470	 610	 620	 630																		
<p>3 <i>Misure del mandrino</i> <i>Medida del cono</i></p> <p>ISO DIN 2080</p>  <table style="width: 100%; text-align: center;"> <tr> <td>ISO 30</td> <td>ISO 40</td> <td>ISO 50</td> </tr> <tr> <td>30</td> <td>40</td> <td>50</td> </tr> </table>	ISO 30	ISO 40	ISO 50	30	40	50															
ISO 30	ISO 40	ISO 50																			
30	40	50																			
<p>4 <i>Misure dell'adattatore</i> <i>Medida del adaptador</i></p> <table border="1" style="width: 100%; text-align: center;"> <tr> <td style="width: 15%;"></td> <td style="width: 15%;">K_1 - MORSE </td> <td style="width: 15%;">K_1 - ISO </td> <td style="width: 15%;"></td> <td style="width: 15%;"></td> </tr> <tr> <td>Ø 16 Ø 22 Ø 27 Ø 32 Ø 40 Ø 60 16 22 27 32 40 60</td> <td>MK1 MK2 MK3 MK4 01 02 03 04</td> <td>ISO 30 ISO 40 30 40</td> <td>B12 B16 B18 12 16 18</td> <td>Ø 8 Ø 13 Ø 16 8 13 16</td> </tr> <tr> <td>Ø 6 ... Ø 50 6 ... 50</td> <td>ER16 ER20 ER25 ER32 ER40 16 20 25 32 40</td> <td>ER16 ER20 ER25 ER32 ER40 16 20 25 32 40</td> <td>Ø 50 Ø 63 Ø 80 Ø 85 Ø 90 50 63 80 85 90</td> <td>M3-M12 M4-M20 M8-M33 12 20 33</td> </tr> </table>		K_1 - MORSE 	K_1 - ISO 			Ø 16 Ø 22 Ø 27 Ø 32 Ø 40 Ø 60 16 22 27 32 40 60	MK1 MK2 MK3 MK4 01 02 03 04	ISO 30 ISO 40 30 40	B12 B16 B18 12 16 18	Ø 8 Ø 13 Ø 16 8 13 16	Ø 6 ... Ø 50 6 ... 50	ER16 ER20 ER25 ER32 ER40 16 20 25 32 40	ER16 ER20 ER25 ER32 ER40 16 20 25 32 40	Ø 50 Ø 63 Ø 80 Ø 85 Ø 90 50 63 80 85 90	M3-M12 M4-M20 M8-M33 12 20 33						
	K_1 - MORSE 	K_1 - ISO 																			
Ø 16 Ø 22 Ø 27 Ø 32 Ø 40 Ø 60 16 22 27 32 40 60	MK1 MK2 MK3 MK4 01 02 03 04	ISO 30 ISO 40 30 40	B12 B16 B18 12 16 18	Ø 8 Ø 13 Ø 16 8 13 16																	
Ø 6 ... Ø 50 6 ... 50	ER16 ER20 ER25 ER32 ER40 16 20 25 32 40	ER16 ER20 ER25 ER32 ER40 16 20 25 32 40	Ø 50 Ø 63 Ø 80 Ø 85 Ø 90 50 63 80 85 90	M3-M12 M4-M20 M8-M33 12 20 33																	

AT3 CARATTERISTICHE TECNICHE DEI MANDRINI AT3 CARACTERÍSTICAS TÉCNICAS DE LOS CONOS

MATERIALE:

- Acciaio da cementazione al cromo-manganese 1.7131 (16MnCr5).

ESECUZIONE:

- Carburato, temprato e ricotto.
- Durezza superficiale HRC 58±2 (670±40 HV30)
- Profondità dello strato carburato minimo 0,5 mm.
- Resistenza alla trazione nel nucleo minimo 800 N/mm² dopo la carburazione.

PRECISIONE:

- Cono secondo DIN 254
- Angolo del cono:
tolleranza AT 3 DIN 7178 parte 1 e DIN 2080 parte 1.
- Altre tolleranze secondo DIN 7160 e 7168.
- Rugosità superficiale del cono RZ<0,001 mm.

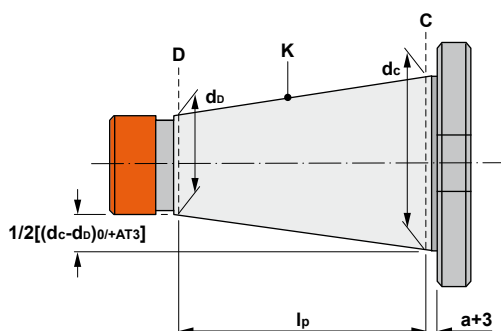

TOLLERANZA AT:

- Indica la tolleranza del piano di misurazione D tra il valore reale e il valore teorico della conicità del cono.
- Questo valore del piano di misurazione D deve essere sempre in meno (negativo), mai in più (positivo), per poter GARANTIRE un buon fissaggio del mandrino nel diametro maggiore del cono.

MATERIAL:

- Acero de cementación al cromo-manganese 1.7131 (16MnCr5).

EJECUCIÓN:

- Cementado, templado y revenido.
- Dureza superficial HRC 58±2 (670±40 HV30)
- Profundidad capa cementada mínimo 0,5 mm.
- Resistencia a la tracción en el núcleo mínimo 800 N/mm² después del cementado.

PRECISIÓN:

- Cono según DIN 254
- Ángulo del cono: tolerancia AT 3 DIN 7178 parte 1 y DIN 2080 parte 1.
- Otras tolerancias según DIN 7160 y 7168.
- Rugosidad superficial del cono RZ<0,001 mm.

K	AT3 mm
ISO 30	0,002
ISO 40	0,003
ISO 45	0,003
ISO 50	0,004
ISO 60	0,005

TOLERANZA AT:

- Indica la tolerancia en el plano de la medida D entre el valor real de la conicidad del cono y el valor teórico.
- Este valor en el plano D debe ser siempre en menos (negativo), nunca en más (positivo), para así poder GARANTIZAR una buena sujeción del cono en su mayor diámetro.

10 DIN 2080

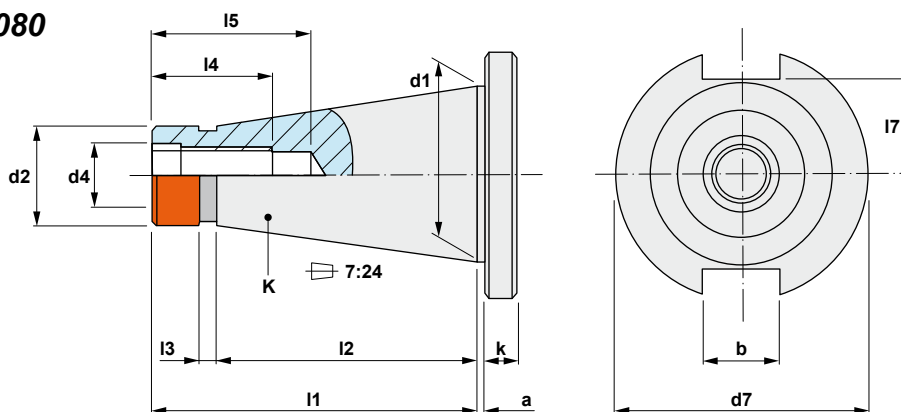

K	a ±0,2	b H12	d1	d2	d4	d7	k	l1	l2	l3	l4	l5 min	l7 max
30	1,6	16,1	31,75	17,4	M12	50,0	8	68,4	48,4	3	24	33,5	16,2
40	1,6	16,1	44,45	25,3	M16	63,0	10	93,4	65,4	5	32	42,5	22,5
45	3,2	19,3	57,15	32,4	M20	80,0	12	106,8	82,8	6	40	52,5	29,0
50	3,2	25,7	69,85	39,6	M24	97,5	12	126,8	101,8	8	47	61,5	35,3
60	3,2	25,7	107,95	60,2	M30	156,0	16	206,8	161,8	10	59	76,0	60,0

Mandrini e adattatori DIN 2080
Conos y adaptadores DIN 2080

10.160



Pagina / Página 105

10.165



Pagina / Página 106

10.180



Pagina / Página 107

10.210



Pagina / Página 108

10.215



Pagina / Página 109

10.216



Pagina / Página 110

10.220



Pagina / Página 111

10.225



Pagina / Página 112

10.290



Pagina / Página 113

10.295



Pagina / Página 114

10.296



Pagina / Página 115

10.300



Pagina / Página 116

10.302



Pagina / Página 117

10.353



Pagina / Página 118

10.453



Pagina / Página 119

10.457



Pagina / Página 120

10.470



Pagina / Página 121

10.610



Pagina / Página 122

10.620



Pagina / Página 123





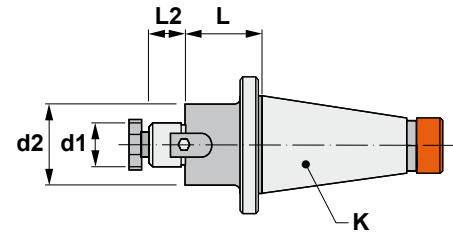

Caratteristiche:
Mandrino portafrese fisso.
DIN 2080 / ISO 3937
Per frese con trascinatore
frontale DIN 138.

Características:
Cono portafresas.
DIN 2080 / ISO 3937
Para fresas con chaveta
frontal DIN 138.



10.160

Riferimento Referencia	K ISO	d1 h6	L	L2	d2				
10.160.30.16	30	16	30	17	38	10008	86016	11103	0,480
10.160.30.22	30	22	30	19	48	10010	86022	11004	0,570
10.160.30.27	30	27	30	21	58	10012	86027	11005	0,700
10.160.30.32	30	32	35	24	78	10016	86032	11105	0,840
10.160.40.16	40	16	30	17	38	10008	86016	11103	0,950
10.160.40.16/100	40	16	100	17	38	10008	86016	11103	1,370
10.160.40.22	40	22	30	19	48	10010	86022	11004	1,040
10.160.40.22/100	40	22	100	19	48	10010	86022	11004	1,830
10.160.40.27	40	27	30	21	58	10012	86027	11005	1,160
10.160.40.27/100	40	27	100	21	58	10012	86027	11005	2,310
10.160.40.32	40	32	35	24	63	10016	86032	11105	1,320
10.160.40.32/125	40	32	125	24	63	10016	86032	11105	3,134
10.160.40.40	40	40	40	27	73	10020	86040	11006	1,620
10.160.50.16	50	16	35	17	38	10008	86016	11103	2,840
10.160.50.22	50	22	35	19	48	10010	86022	11004	2,950
10.160.50.27	50	27	35	21	58	10012	86027	11005	3,070
10.160.50.27/150	50	27	150	21	58	10012	86027	11005	5,070
10.160.50.32	50	32	40	24	63	10016	86032	11105	3,230
10.160.50.32/150	50	32	150	24	63	10016	86032	11105	6,370
10.160.50.40	50	40	40	27	73	10020	86040	11006	3,990
10.160.50.50	50	50	40	30	90	10024	86050	11008	3,990



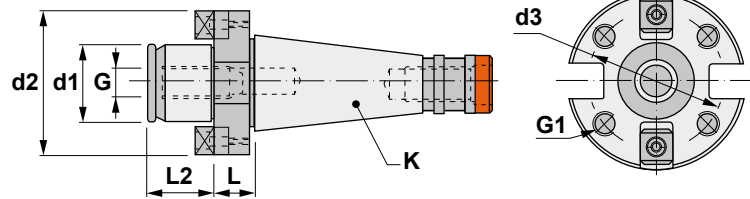

Caratteristiche:
Mandrino portafrese per frese con
inserti a fissaggio meccanico.
DIN 2080 / DIN 6357 - Forma A

Características:
Cono para platos de fresar.
DIN 2080 / DIN 6357 - Forma A



10.165

Riferimento Referencia	K ISO	d1 g5	L	d2	d3	G	G1	L2	
10.165.40.40	40	40	20	89	66,7	M-20	M-12	30	1,410
10.165.50.40	50	40	30	89	66,7	M-20	M-12	30	3,430
10.165.50.60	50	60	30	129	101,6	M-30	M-16	40	4,210

Riferimento Referencia	2x 	2x 
10.165.40.40	80040	11006
10.165.50.40	80040	11006
10.165.50.60	80060	11012

**Caratteristiche:**



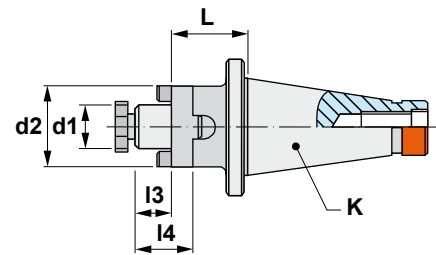

Mandrino portafrese combinato.
DIN 2080 / DIN 6358 - Forma A
Per frese con linguetta o
trascinatore frontale DIN 138.

Características:

Cono portafresas combinado.
DIN 2080 / DIN 6358 - Forma A
Para fresas con chavetas o arrastre
longitudinal DIN 138.



10.180

Riferimento Referencia	K ISO	d1 h6	L	I3	I4	d2				
10.180.30.16	30	16	35	17	27	32	10008	60116	88016	0,560
10.180.30.22	30	22	35	19	31	40	10010	60122	88022	0,690
10.180.30.27	30	27	35	21	33	48	10012	60127	88027	0,830
10.180.30.32	30	32	50	24	38	58	10016	60132	88032	1,360
10.180.40.16	40	16	52	17	27	32	10008	60116	88016	1,130
10.180.40.16/125	40	16	125	17	27	32	10008	60116	88016	1,670
10.180.40.22	40	22	52	19	31	40	10010	60122	88022	1,310
10.180.40.27	40	27	52	21	33	48	10012	60127	88027	1,530
10.180.40.27/125	40	27	125	21	33	48	10012	60127	88027	2,930
10.180.40.32	40	32	52	24	38	58	10016	60132	88032	1,840
10.180.40.32/125	40	32	125	24	38	58	10016	60132	88032	3,390
10.180.40.40	40	40	52	27	41	70	10020	60140	88040	2,430
10.180.50.16	50	16	55	17	27	32	10008	60116	88016	3,120
10.180.50.16/125	50	16	125	17	27	32	10008	60116	88016	3,650
10.180.50.22	50	22	55	19	31	40	10010	60122	88022	3,340
10.180.50.22/125	50	22	125	19	31	40	10010	60122	88022	3,650
10.180.50.22/200	50	22	200	19	31	40	10010	60122	88022	5,130
10.180.50.27	50	27	55	21	33	48	10012	60127	88027	3,520
10.180.50.27/125	50	27	125	21	33	48	10012	60127	88027	4,860
10.180.50.27/200	50	27	200	21	33	48	10012	60127	88027	6,220
10.180.50.32	50	32	55	24	38	58	10016	60132	88032	3,830
10.180.50.32/125	50	32	125	24	38	58	10016	60132	88032	5,980
10.180.50.32/200	50	32	200	24	38	58	10016	60132	88032	8,280
10.180.50.40	50	40	55	27	41	70	10020	60140	88040	4,420
10.180.50.40/125	50	40	125	27	41	70	10020	60140	88040	6,770
10.180.50.50	50	50	55	30	46	90	10024	60150	88050	4,400



Caratteristiche:

Mandrino di riduzione.
DIN 2080 / DIN 6364 - Forma A ISO 5415
Per utensili con attacco cono Morse e
foro filettato DIN 228-A.

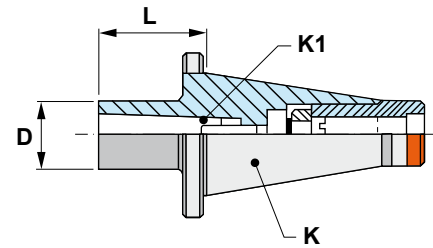

Características:

Cono reductor.
DIN 2080 / DIN 6364 - Forma A ISO 5415
Para herramientas con mango cono
Morse y rosca tirante DIN 228-A.



10.210

Riferimento Referencia	K ISO	K1 MORSE	L	D	
10.210.30.01	30	1	50	25	0,480
10.210.30.02	30	2	50	32	0,570
10.210.30.03	30	3	76	40	0,750
10.210.40.01	40	1	50	25	0,940
10.210.40.02	40	2	50	32	0,940
10.210.40.03	40	3	65	40	1,110
10.210.40.04	40	4	95	48	1,520
10.210.50.01	50	1	60	25	2,940
10.210.50.02	50	2	60	32	2,960
10.210.50.03	50	3	65	40	3,020
10.210.50.04	50	4	65	48	3,070
10.210.50.05	50	5	100	63	3,540

Riferimento Referencia			
10.210.30.01	16004	19312	11406
10.210.30.02	16005	19315	12110
10.210.30.03	16005	19318	12012
10.210.40.01	16105	19516	11506
10.210.40.02	16205	19416	12110
10.210.40.03	16205	19420	11312
10.210.40.04	16205	19322	12016
10.210.50.01	16205	19624	11206
10.210.50.02	16205	19324	11210
10.210.50.03	16205	19524	11512
10.210.50.04	16205	19424	12016
10.210.50.05	16205	19338	11020

**Caratteristiche:**

Mandrino di riduzione.
DIN 2080 / DIN 6383 - ISO 4202
Per utensili con attacco cono Morse
e dente di trascinamento DIN 228-1
forma B.

Características:

Cono reductor.
DIN 2080 / DIN 6383 - ISO 4202
Para herramientas con mango
cono Morse y tetón de arrastre
DIN 228-B.

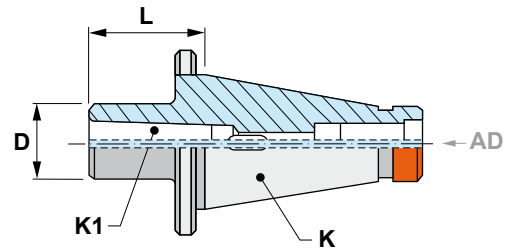

10.215

Riferimento Referencia	K ISO	K1 MORSE	L	D	
10.215.30.01	30	1	50	25	0,470
10.215.30.02	30	2	50	32	0,490
10.215.30.03	30	3	76	40	0,720
10.215.40.01	40	1	50	25	0,870
10.215.40.02	40	2	50	32	0,900
10.215.40.03	40	3	65	40	1,050
10.215.40.04	40	4	95	48	1,380
10.215.50.01	50	1	45	25	2,790
10.215.50.02	50	2	60	32	2,890
10.215.50.03	50	3	65	40	2,920
10.215.50.04	50	4	70	48	2,940
10.215.50.05	50	5	105	63	3,370



Caratteristiche:
Mandrino di riduzione prolungato DIN 2080.
Per utensili con attacco cono Morse e dente di trascinamento DIN 228-B.

Características:
Cono reductor alargado. DIN 2080
Para herramientas con mango cono Morse y tetón de arrastre DIN 228-B.

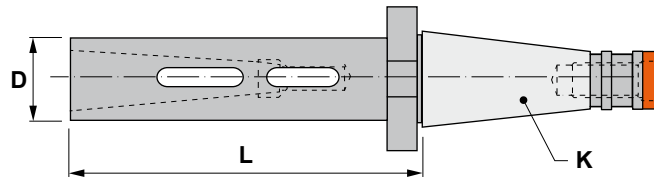

10.216

Riferimento Referencia	K ISO	K1 MORSE	L	D	
10.216.40.02	40	2	110	32	1,320
10.216.40.03	40	3	135	40	1,720
10.216.40.04	40	4	160	48	2,240
10.216.50.02	50	2	115	32	3,290
10.216.50.03	50	3	140	40	3,740
10.216.50.04	50	4	165	48	4,270
10.216.50.05	50	5	215	63	6,000



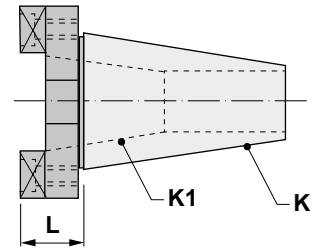

Caratteristiche:
Mandrino di riduzione.
DIN 2080
Per utensili con attacco DIN 2080 ISO.

Características:
Cono reductor.
DIN 2080
Para herramientas con mango cónico DIN 2080 ISO.



10.220

Riferimento Referencia	K ISO	K1 ISO	L	KG
10.220.40.30	40	30	19	0,740
10.220.50.30	50	30	23	2,580
10.220.50.40	50	40	23	2,470

Riferimento Referencia	2x 	2x 
10.220.40.30	80440	11006
10.220.50.30	80440	11006
10.220.50.40	80440	11006





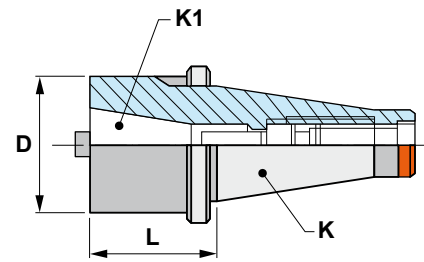

Caratteristiche:
Mandrino di riduzione.
DIN 2080
Per utensili con attacco DIN 2080 ISO.

Características:
Cono reductor.
DIN 2080
Para herramientas con mango cónico
DIN 2080 ISO.



10.225

Riferimento Referencia	K ISO	K1 ISO	L	D	
10.225.40.30	40	30	50	50	1,190
10.225.50.30	50	30	50	50	3,050
10.225.50.40	50	40	50	63	3,140

Riferimento Referencia			
10.225.40.30	16205	19420	11312
10.225.50.30	16205	19524	11512
10.225.50.40	16205	19424	12016

**Caratteristiche:**

Mandrino per portapunte.
DIN 2080
Per portapunte con attacco cono DIN 238.

Características:

Cono para portabrocas.
DIN 2080
Para portabrocas con cono DIN 238.

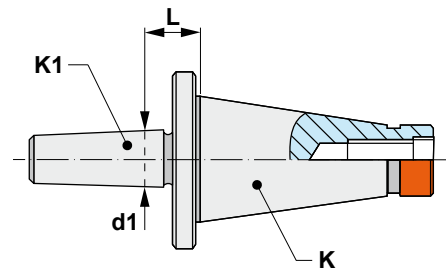

10.290

Riferimento Referencia	K ISO	K1 DIN 238	L	d1	
10.290.30.12	30	B-12	15	12,065	0,390
10.290.30.16	30	B-16	15	15,733	0,380
10.290.30.18	30	B-18	15	17,780	0,360
10.290.40.12	40	B-12	17	12,065	0,860
10.290.40.16	40	B-16	17	15,733	0,880
10.290.40.18	40	B-18	17	17,780	0,890
10.290.50.16	50	B-16	20	15,733	2,880
10.290.50.18	50	B-18	20	17,780	2,920

MU

 I199

Riferimento / Ref.	Accessori / Accesorios
--------------------	------------------------

MU	Mandrini portapunte standard DIN 238 senza chiave Portabrocas de cierre rápido estándar DIN 238 sin llave
----	--



MP

 I200

Riferimento / Ref.	Accessori / Accesorios
--------------------	------------------------

MP	Mandrini portapunte di superprecisione DIN 238 senza chiave Portabrocas de superprecisión DIN 238 sin llave
----	--



MK

 I201

Riferimento / Ref.	Accessori / Accesorios
--------------------	------------------------

MK	Mandrini portapunte autobloccanti di superprecisione DIN 238 con chiave Portabrocas autoblocantes de superprecisión DIN 238 con llave
----	--





Caratteristiche:
Mandrino portapunte corto
autoserrante ad alta precisione.
DIN 2080
Per rotazione destra.

*** CHIAVE DI SERRAGGIO INCLUSA**

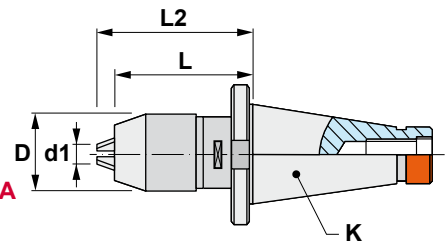

Características:
Portabrocas corto de precisión autoblocante.
DIN 2080
Rotación solamente a derechas.

*** SE SUMINISTRA CON LLAVE**



10.295

Riferimento Referencia	K ISO	d1	D	L	L2 max	
10.295.30.08	30	0,3-8	38	70	76	1,000
10.295.40.08	40	0,3-8	38	63	69	1,400
10.295.40.13	40	1-13	48	78	89	1,700
10.295.40.16	40	3-16	55	90	101	2,100
10.295.50.13	50	1-13	48	71	101	3,600
10.295.50.16	50	3-16	55	72	83	3,750

Riferimento Referencia		
10.295.30.08	50008	11206
10.295.40.08	50008	11206
10.295.40.13	50013	11108
10.295.40.16	50016	11108
10.295.50.13	50013	11108
10.295.50.16	50016	11108

**Caratteristiche:**

Mandrina portapunte con serraggio di precisione CNC universale.
DIN 2080
Per rotazione destra e sinistra.

*** CHIAVE DI SERRAGGIO INCLUSA**

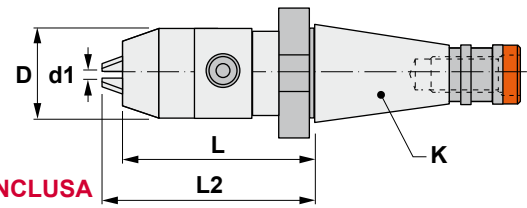

**Características:**

Portabrocas de precisión
CNC-Universal.
DIN 2080
Rotación a izquierda y derecha.

*** SE SUMINISTRA CON LLAVE**

10.296

Riferimento Referencia	K ISO	d1	D	L	L2 max	
10.296.40.13	40	1-13	54	82	91	1,840
10.296.40.16	40	3-16	57	85	92	2,000
10.296.50.13	50	1-13	54	85	94	3,320
10.296.50.16	50	3-16	57	88	95	3,420

Riferimento Referencia		3x 
10.296.40.13	5006	60313
10.296.40.16	5006	60313
10.296.50.13	5006	60313
10.296.50.16	5006	60313





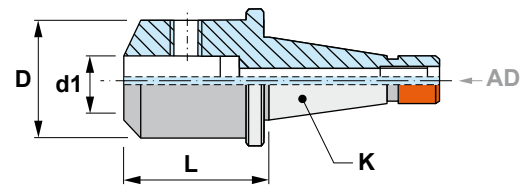

Caratteristiche:
Mandrino portafrese Weldon.
DIN 2080 / DIN 6359
Forma A ISO 5414
Per fresa con attacco cilindrico e piano di trascinamento Weldon DIN 1835-B.



Características:
Cono portafresas tipo Weldon.
DIN 2080 / DIN 6359
Forma A ISO 5414
Para fresas con mango cilíndrico y plano de arrastre Weldon DIN 1835-B.

10.300

Riferimento Referencia	K ISO	d1 h4	L	D		
10.300.30.06	30	6	40	25	15106	0,410
10.300.30.08	30	8	40	28	15108	0,430
10.300.30.10	30	10	40	35	15110	0,500
10.300.30.12	30	12	40	42	15212	0,560
10.300.30.14	30	14	40	44	15212	0,580
10.300.30.16	30	16	50	48	15314	0,750
10.300.30.18	30	18	50	50	15314	0,760
10.300.40.06	40	6	50	25	15106	0,880
10.300.40.08	40	8	50	28	15108	0,950
10.300.40.10	40	10	50	35	15110	1,010
10.300.40.12	40	12	50	42	15212	1,110
10.300.40.14	40	14	63	44	15212	1,290
10.300.40.16	40	16	63	48	15314	1,370
10.300.40.18	40	18	63	50	15314	1,400
10.300.40.20	40	20	63	52	15216	1,410
10.300.40.25	40	25	80	65	2 x 15218	2,180
10.300.40.32	40	32	80	72	2 x 15220	2,550
10.300.40.40	40	40	102	90	2 x 15220	4,120
10.300.50.06	50	6	63	25	15106	2,850
10.300.50.08	50	8	63	28	15108	2,890
10.300.50.10	50	10	63	35	15110	2,940
10.300.50.12	50	12	63	42	15212	3,140
10.300.50.14	50	14	63	44	15212	3,130
10.300.50.16	50	16	63	48	15314	3,180
10.300.50.18	50	18	63	50	15314	3,220
10.300.50.20	50	20	63	52	15216	3,270
10.300.50.25	50	25	80	65	2 x 15218	3,980
10.300.50.32	50	32	80	72	2 x 15220	4,210
10.300.50.40	50	40	90	90	2 x 15220	5,310
10.300.50.50	50	50	100	98	2 x 15024	6,060

42.300

 1182

Riferimento / Ref. Accessori / Accesorios

42.300 Bussole di riduzione corte e lunghe DIN 1835-B Forma A e B
Casquillos de reducción cortos y largos DIN 1835-B Forma A y B



**Caratteristiche:**



Mandrino portafrese corto.
DIN 2080
Per frese e utensili con attacco cilindrico e piano di trascinamento Weldon DIN 1835-B.

Características:

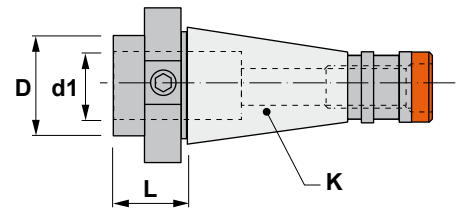
Cono portafresas corto.
DIN 2080
Para fresas y útiles con mango cilíndrico y plano de arrastre Weldon DIN1835-B.



10.302

Riferimento Referencia	K ISO	d1 h4	L	D		
10.302.30.16	30	16	20	32	15114	0,400
10.302.30.20	30	20	34	36	15014	0,390
10.302.40.16	40	16	22	44	15214	0,850
10.302.40.20	40	20	22	44	15116	0,800
10.302.40.25	40	25	22	44	15016	0,710
10.302.50.16	50	16	16	-	15314	2,710
10.302.50.20	50	20	16	-	15216	2,640
10.302.50.25	50	25	16	-	15118 + 15218	2,540
10.302.50.32	50	32	16	-	15020 + 15120	2,330

42.610

 I183

Riferimento / Ref.	Accessori / Accesorios
--------------------	------------------------

42.610	Mandrino per maschiare con compensazione assiale DIN 1835-B Roscador con compensación axial del paso de rosca DIN 1835-B
--------	---



42.620

 I184

Riferimento / Ref.	Accessori / Accesorios
--------------------	------------------------

42.620	Mandrino per maschiare a cambio rapido con compensazione assiale DIN 1835-B+E Roscador de cambio rápido con compensación axial del paso de rosca DIN 1835-B+E
--------	--





Caratteristiche:

Mandrino portapinze per pinze DIN 6388.
DIN 2080
Per utensili con attacco cilindrico
DIN 1835-B.
* Ghiera a sfere, vedere pagina: I220

*** CHIAVE DI SERRAGGIO NON INCLUSA**

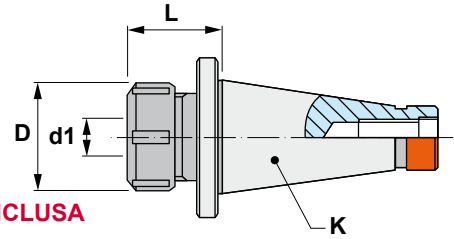





Características:

Cono portapinzas para pinzas DIN 6388.
DIN 2080.
Para herramientas con mango cilíndrico
DIN 1835-B.
* Tuerca a bolas, vea página: I220

*** SE SUMINISTRA SIN LLAVE**

10.353

Riferimento Referencia	K ISO	L	d1	D				
10.353.30.16	30	43	2-16	43	43316	50116	19216	0,490
10.353.30.25	30	70	3-25	60	43325	50125	19216	0,880
10.353.40.16	40	50	2-16	43	43316	50116	19216	0,970
10.353.40.25	40	63	3-25	60	43325	50125	19224	1,200
10.353.40.32	40	90	4-32	72	43332	50132	19224	1,840
10.353.50.25	50	63	3-25	60	43325	50125	19224	2,660
10.353.50.32	50	70	4-32	72	43332	50132	19230	3,330

BXX

 I206-208

Riferimento / Ref. Accessori / Accesorios

BXX Pinze a doppio intaglio DIN 6388 - Forma B
Pinzas de doble ranura DIN 6388 - Forma B



**Caratteristiche:**

Mandrino portapinzas per pinzas DIN 6499 (ER). DIN 2080.
Per utensili con attacco cilindrico.

* Ghiera a sfere, vedere pagina: I221

*** CHIAVE DI SERRAGGIO NON INCLUSA**

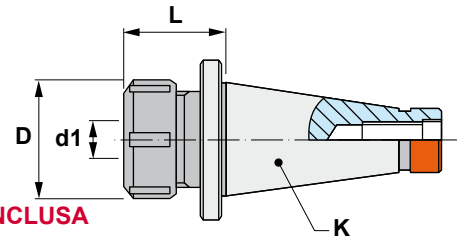
**Características:**

Cono portapinzas para pinzas DIN 6499 (ER). DIN 2080.
Para herramientas con mango cilíndrico.

* Tuerca a bolas, vea página: I221

*** SE SUMINISTRA SIN LLAVE**

10.453

Riferimento Referencia	K ISO		L	d1	D	D1				
10.453.30.16	30	ER16	35	0,5-10	32	-	45316	50216	19210	0,329
10.453.30.20	30	ER20	38	1-13	35	-	45320	50220	19212	0,324
10.453.30.25	30	ER25	42	1-16	42	-	45325	50225	19216	0,480
10.453.30.32	30	ER32	50	2-20	50	-	45332	50232	19218	0,520
10.453.40.25	40	ER25	44	1-16	42	-	45325	50225	19216	0,920
10.453.40.32	40	ER32	48	2-20	50	-	45332	50232	19218	0,950
10.453.40.32/070	40	ER32	70	2-20	50	-	45332	50232	19218	1,140
10.453.40.32/100	40	ER32	100	2-20	50	50	45332	50232	19218	1,506
10.453.40.32/150	40	ER32	150	2-20	50	50	45332	50232	19218	2,050
10.453.40.40	40	ER40	51	3-30	63	-	45340	50240	19224	1,070
10.453.40.40/100	40	ER40	100	3-30	63	63	45340	50240	19224	1,400
10.453.50.25	50	ER25	46	1-16	42	-	45325	50225	19216	2,870
10.453.50.25/150	50	ER25	150	1-16	42	42	45325	50225	19216	3,600
10.453.50.32	50	ER32	60	2-20	50	-	45332	50232	19218	2,960
10.453.50.32/100	50	ER32	100	2-20	50	50	45332	50232	19218	3,080
10.453.50.32/150	50	ER32	150	2-20	50	50	45332	50232	19218	3,920
10.453.50.40	50	ER40	60	3-30	63	-	45340	50240	19224	3,120
10.453.50.40/150	50	ER40	150	3-30	63	63	45340	50240	19224	4,530
10.453.50.50	50	ER50	65	6-34	78	-	45350	50250	19230	3,270

ERXX

I210-212

Riferimento / Referencia

ERXX

**40.453..**

I180

Riferimento / Referencia

40.453..

**ERCXX**

I215-216

Riferimento / Referencia

ERCXX

**40.455..**

I181

Riferimento / Referencia

40.455..

**ERTXX**

I217-218

Riferimento / Referencia

ERTXX





Caratteristiche:

Mandrino portapinzas a chiusura meccanica con forte serraggio e precisione. DIN 2080
Per pinze DIN 6499 (ER).

L'alternativa al sistema idraulico e ad altri sistemi.
Con refrigerazione centrale.

*** CHIAVE DI SERRAGGIO INCLUSA**

Características:

Cono portapinzas de cierre mecánico con gran fuerza de amarre y precisión.
DIN 2080.



Para pinzas DIN 6499 (ER).

La alternativa al sistema hidráulico y a otros sistemas.
Con refrigeración por el centro.

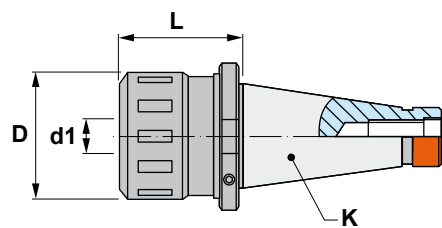
*** SE SUMINISTRA CON LLAVE**



10.457

Riferimento Referencia	K ISO		L	d1	D				
10.457.40.32	40	ER32	80	2-20	54	45732	50704	19006	1,620
10.457.50.32	50	ER32	85	2-20	54	45732	50704	19006	3,630
10.457.50.40	50	ER40	97	3-30	65	45740	50706	19010	4,570

ERXX

 I210-212

Riferimento / Ref. Accessori / Accesorios

ERXX Pinze a doppio intaglio DIN 6499 - Forma B (ER)
Pinzas de doble ranura DIN 6499 - Forma B (ER)



ERCXX

 I215-216

Riferimento / Ref. Accessori / Accesorios

ERCXX Pinze a tenuta stagna DIN 6499 (ER)
Pinzas estancas DIN 6499 (ER)





Caratteristiche:
Mandrino a
stelo tenero.

Características:
Cono premecanizado
blando.

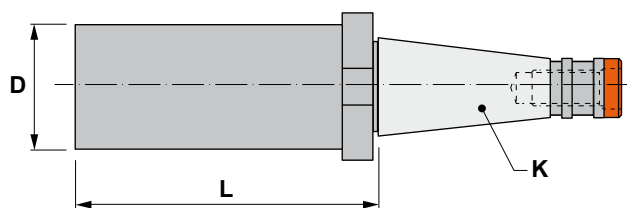

10.470

Riferimento Referencia	K ISO	D	L	 Kg
10.470.40.63/250	40	63,5	250	6,760
10.470.50.95/315	50	95,5	315	18,470



Caratteristiche:

Maschiatore con compensazione assiale.
DIN 2080.
Per pinze DIN 6499 (ER) e con refrigerazione interna.
Compensazione nella compressione (C) e nella tensione (T).
Si può bloccare la compressione girando l'anello posteriore (A).
Controllo della profondità della filettatura.

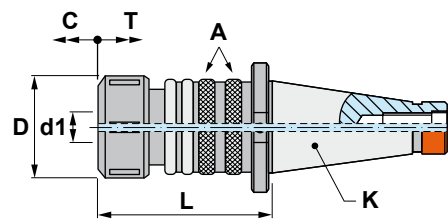





*** CHIAVE DI SERRAGGIO INCLUSA**

Características:

Rosgador con compensación axial del paso de la rosca.
DIN 2080.
Para pinzas DIN 6499 (ER) y con refrigeración interior.
Compensación a la compresión (C) y a la tracción (T).
Posibilidad de bloquear la compresión girando el anillo posterior (A). Control de la profundidad de roscado.

*** SE SUMINISTRA CON LLAVE**

10.610

Riferimento Referencia	K ISO			d1	L	D	C	T			
10.610.30.16	30	ER16	M3-M12	100,5	28	5,5	6,0	45316	50216	0,900	
10.610.40.16	40	ER16	M3-M12	88,5	28	5,5	6,0	45316	50216	1,300	
10.610.40.25	40	ER25	M4-M20	112,0	42	10,5	7,5	45325	50225	1,850	
10.610.40.40	40	ER40	M8-M33	128,0	63	10,0	10,0	45340	50240	3,050	
10.610.50.16	50	ER16	M3-M12	82,5	28	5,5	6,0	45316	50216	3,100	
10.610.50.25	50	ER25	M4-M20	106,0	42	10,5	7,5	45325	50225	3,650	
10.610.50.40	50	ER40	M8-M33	122,0	63	10,0	10,0	45340	50240	4,850	

ERXX

 I210-212

Riferimento / Ref. Accessori / Accesorios

ERXX Pinze a doppio intaglio DIN 6499 - Forma B (ER)
Pinzas de doble ranura DIN 6499 - Forma B (ER)



ERCXX

 I215-216

Riferimento / Ref. Accessori / Accesorios

ERCXX Pinze a tenuta stagna DIN 6499 (ER)
Pinzas estancas DIN 6499 (ER)



ERTXX

 I217-218

Riferimento / Ref. Accessori / Accesorios

ERTXX Pinze DIN 6499 - Forma Mexin (ER)
Pinzas DIN 6499 - Forma Mexin (ER)



40.453..

 I180

Riferimento / Ref. Accessori / Accesorios

40.453.. Mandrini portapinze per pinze DIN 6499 (ER)
Portapinzas para pinzas DIN 6499 (ER)



40.455..

 I181

Riferimento / Ref. Accessori / Accesorios

40.455.. Mandrini portapinze lunghi per pinze DIN 6499 (ER)
Portapinzas alargado para pinzas DIN 6499 (ER)



**Caratteristiche:**

Maschiatore a cambio rapido con compensazione assiale. DIN 2080
Per bussole portamaschi tipo Bilz.

Compensazione della compressione (C) e della tensione (T).



Características:

Roscador de cambio rápido con compensación axial del paso de la rosca. Con cabezillas portamachos sistema Bilz.

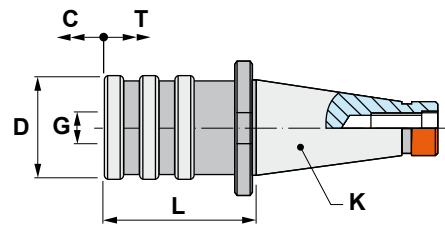
Compensación a la compresión (C) y a la tracción (T).



10.620

Riferimento Referencia	K ISO	Nº. ^G Ø	d1	L	D	C	T			
10.620.30.12	30	1 19	M3-M12	41	38	9	9	710XX	750XX	0,580
10.620.40.12	40	1 19	M3-M12	52	38	9	9	710XX	750XX	1,070
10.620.40.20	40	2 31	M8-M20	77	55	15	15	720XX	760XX	1,460
10.620.40.33	40	3 48	M14-M33	97	79	24	24	730XX	770XX	3,500
10.620.50.12	50	1 19	M3-M12	41	38	9	9	710XX	750XX	4,600
10.620.50.20	50	2 31	M8-M20	79	55	15	15	720XX	760XX	4,600
10.620.50.33	50	3 48	M14-M33	125	79	24	24	730XX	770XX	5,090

710XX..730XX

 I202

Riferimento / Ref.

Accessori / Accesorios

710XX..730XX

Bussole a cambio rapido senza frizione
Cabezillas de cambio rápido sin embrague



750XX..770XX

 I203

Riferimento / Ref.

Accessori / Accesorios

750XX..770XX

Bussole a cambio rapido con frizione
Cabezillas de cambio rápido con embrague



1 TIPO / MODELO

10.160	10.165	10.180	10.210	10.215
10.216	10.220	10.225	10.290	10.295
10.296	10.300	10.302	10.353	10.453
10.457	10.470	10.610	10.620	

2 DIMENSIONI / MEDIDA

30	40	50	60
-----------	-----------	-----------	-----------

3 LUNGHEZZA / LONGITUD (L)

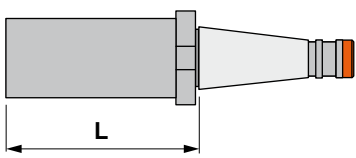
	<hr/> <hr/> <hr/> <hr/>
---	-------------------------

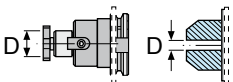
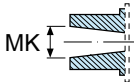
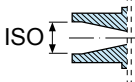
<p>Ø DIAMETRO / DIÁMETRO</p> 	<p>MK</p> 	<p>ISO</p> 	<p>PINZA</p>

NOTE / ANOTACIONES: _____
