



MILLING CUTTERS

Applications index	G16-17
Facing square shoulder cutters	G18-29
Cutting data for facing square milling cutters	G30-31
Facing milling cutters	G32-47
Cutting data for facing milling cutters	G40-41
Slot cutters	G48
Cutting data for slot cutters	G49
High feed	G52-55
Cutting data for high feed	G56-57
Round inserts	G58-65
Finishing ball nose	G66-67
Cutting data for finishing ball nose	G68-69
Aluminium die cutting	G70
Cutting data for aluminium die cutting	G71

**G**

Facing square shoulder cutters

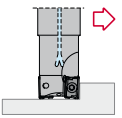
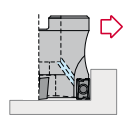
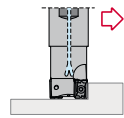
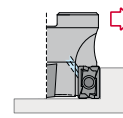
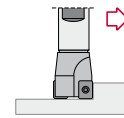
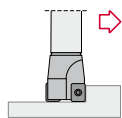
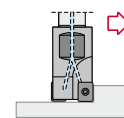
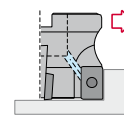
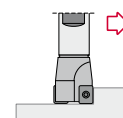
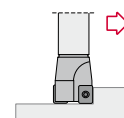
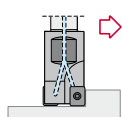
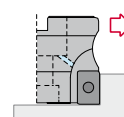
<p>122237 First choice 90°</p>  <p>Page G18 LNMM1006..</p>	<p>122293 First choice 90°</p>  <p>Page G18 LNMM1006..</p>	<p>123237 First choice 90°</p>  <p>Page G20 LNMM1510..</p>	<p>123293 90° First choice 90°</p>  <p>Page G20 LNMM1510..</p>	<p>122021 90° General application 90°</p>  <p>Page G22 AP.1003..</p>
<p>122022 90° General application 90°</p>  <p>Page G22 AP.1003..</p>	<p>122006 90° General application 90°</p>  <p>Page G24 AP.1003..</p>	<p>122093 90° General application 90°</p>  <p>Page G24 AP.1003..</p>	<p>123021 90° General application 90°</p>  <p>Page G26 AP.1604..</p>	<p>123022 90° General application 90°</p>  <p>Page G26 AP.1604..</p>
<p>123006 90° General application 90°</p>  <p>Page G28 AP.1604..</p>	<p>123090 90° General application 90°</p>  <p>Page G28 AP.1604..</p>			

Face milling cutters

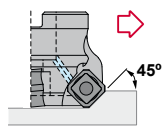
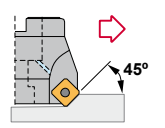
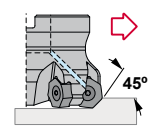
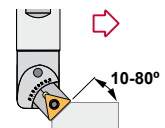
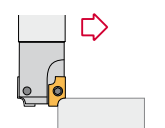
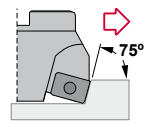
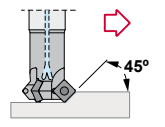
<p>174293 45° Soft materials 45°</p>  <p>Page G32 SNMX1206..</p>	<p>174890 45° Soft materials 45°</p>  <p>Page G34 SEH..1204.. SEMT1204..</p>	<p>185293 45° Multipurpose milling 45°</p>  <p>Page G36 NNMU2007..</p>	<p>162421 Chamfering cutters 10-80°</p>  <p>TC..21.5.. TC..32.5.. Page G44</p>	<p>123507 Concave milling cutters</p>  <p>Page G46 ADMW1503..</p>
<p>143090 75° General application 75°</p>  <p>Page G38 AP.1604..</p>	<p>073503 45° Chamfering 45°</p>  <p>Page G42 SDMT09T3..</p>			



Slot cutters

194290 Slot milling 89°

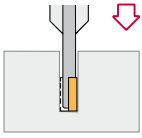

Page G48 SNHX1102..
SNHX1207..

High feed

162903 High feed

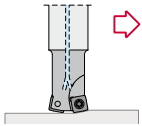

Page G52 SP..0735..
SP..0945..
SP..1155..

162906 High feed

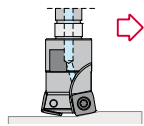

Page G52 SP..0735..
SP..0945..
SP..1155..

163993 High feed

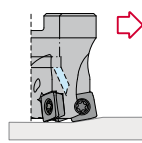

Page G54 SP..0945..

164993 High feed

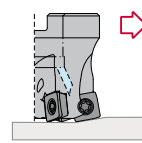

Page G54 SP..1155..

Round inserts

55_5 Facing and copying

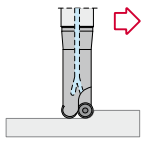

Page G58 RD..1003..
RD..1604..

55_506 Facing and copying

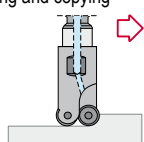

Page G58 RD..1003..
RD..1604..

55_590 Facing and copying

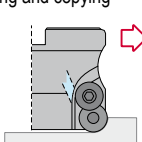

Page G60 RD..1204..
RD..1604..

5549_01_02 Facing and copying

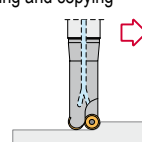

Page G62 RPM..1204..

554990 Facing and copying

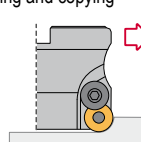

Page G64 RPM..1204..

Finishing ball nose

87_06 Copy applications (Finishing Modular)

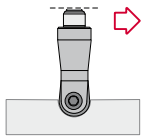

Page G66 HIB..0375
HIB..1250

87_00 Copy applications (Finishing Cylindric)

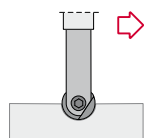

Page G67 HIB..0375
HIB..1250

87_01 Copy applications (Finishing Cylindric)

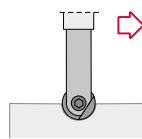

Page G67 HIB..0375
HIB..1250

Aluminium die cutting

034406 General application

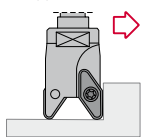

Page G70 VCGT33..
VCGT2205..

034490 General application

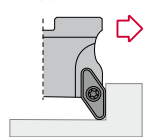

Page G70 VCGT2205..





Characteristics:
Positive milling cutter for diversified manufacture with an exact angle of 90° that uses very strong inserts allowing deep passes and high feed per teeth.

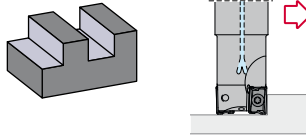
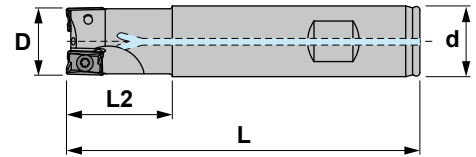

122237

Reference		D	L	d	L2	Insert size	
1222370075	2	0.750	3.500	0.750	1.250	LNMM1006..	0.485
1222370100	3	1.000	3.500	1.000	1.250	LNMM1006..	0.750

Reference			Nm
1222370075	1230	5508	1.2
1222370100	1230	5508	1.2

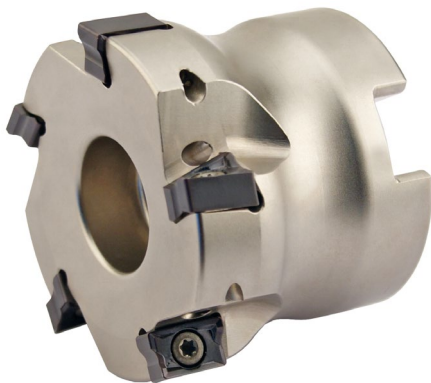

Characteristics:
Positive milling cutter for diversified manufacture with an exact angle of 90° that uses very strong inserts allowing deep passes and high feed per teeth.

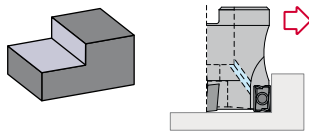
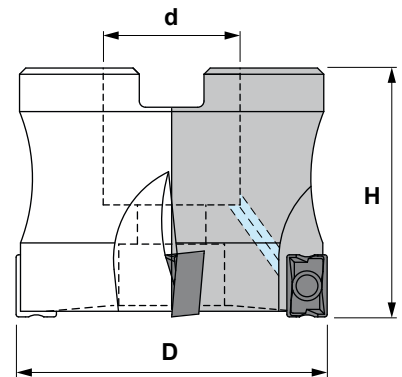

122293 90°

Reference		D	H	d	Insert size	
1222930150	5	1.500	1.750	0.500	LNMM1006..	0.530
1222930200	7	2.000	1.750	0.750	LNMM1006..	0.794

Reference				Nm
1222930150	1230	5508	UNF.14	1.2
1222930200	1230	5508	UNF.38	1.2

Rectangular inserts / Negative

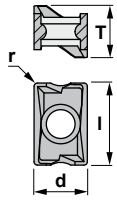

USE CLASSIFICATION

- Continuous
- ◐ Slight interruption
- ✚ Interruption

AVAILABILITY

- Standard item
- Check availability

P Steel	●	✚	✚	✚	✚	●	●	✚
M Stainless	●	●	●	✚	●	●	●	●
K Cast iron	●	✚	✚	✚	●	●	●	●
N Non ferrous materials	✚	●	●	●	●	●	●	✚
S Heat-resistant alloys	●	●	●	●	●	●	●	●
H Hard materials	●	●	●	●	●	●	●	●



LNMM

Reference	l	T	d	r	KM15	PM25	PM40	TIN21	TIN25	ML30	TL10	TL20	TL40	ZR10
LNMM100605	0.394	0.256	0.256	0.020						●			●	

Straight ramping

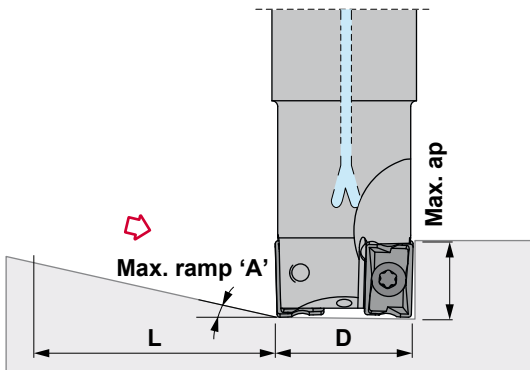

Helical ramping

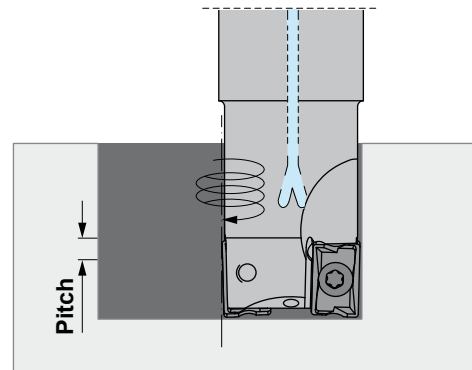

Ramping data for facing square shoulder cutters (122237 / 122293)

Cutter dia. (D)	Straight ramp down			Helical ramp down		
	Max. ramp (A°)	Max. ap	Min. length (L)	Min. dia.	Max. dia.	Max. pitch/rev.
Ø 1.000	1.5	.350	16.535	1.180		.010
					1.970	.065
Ø 1.500	0.8	.350	31.025	2.365		.025
					3.150	.060
Ø 2.000	0.6	.350	41.380	3.150		.030
					3.940	.055





Characteristics:
Positive milling cutter for diversified manufacture with an exact angle of 90° that uses very strong inserts allowing deep passes and high feed per teeth.

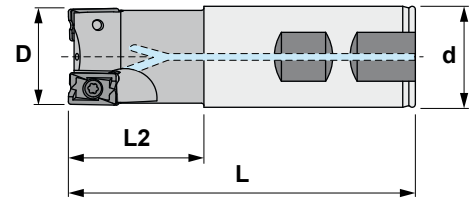
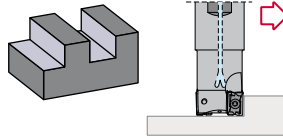

123237

Reference		D	L	d	L2	Insert size	
1232370100	2	1.000	3.500	1.000	1.250	LNMM1510..	0.730
1232370125	3	1.250	3.750	1.000	1.250	LNMM1510..	1.345

Reference			Nm
1232370100	1440	5515	3.0
1232370125	1240	5515	3.0



Characteristics:
Positive milling cutter for diversified manufacture with an exact angle of 90° that uses very strong inserts allowing deep passes and high feed per teeth.

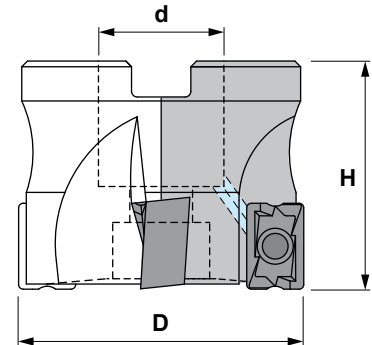
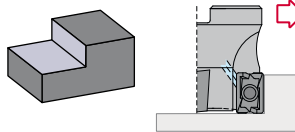

123293 90°

Reference		D	H	d	Insert size	
1232930150	3	1.500	1.750	0.500	LNMM1510..	0.440
1232930200	4	2.000	1.750	0.750	LNMM1510..	0.660
1232930250	6	2.500	2.000	1.000	LNMM1510..	1.435
1232930300	7	3.000	2.000	1.000	LNMM1510..	2.535

Reference				Nm
1232930150	1240	5515	UNF.14	3.0
1232930200	1240	5515	UNF.38	3.0
1232930250	1240	5515	UNF.12	3.0
1232930300	1240	5515	UNF.12	3.0



Rectangular inserts / Negative

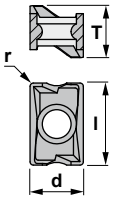

USE CLASSIFICATION

- Continuous
- ◐ Slight interruption
- ⊕ Interruption

AVAILABILITY

- Standard item
- Check availability

P Steel	●	⊕	⊕	⊕	⊕	●	⊕	⊕
M Stainless	●	⊕	⊕	⊕	⊕	●	⊕	⊕
K Cast iron	●	⊕	⊕	⊕	⊕	●	⊕	⊕
N Non ferrous materials	⊕	⊕	⊕	⊕	⊕	⊕	⊕	⊕
S Heat-resistant alloys								
H Hard materials								



LNMM

Reference	l	T	d	r	KM15	PM25	PM40	TIN21	TIN25	ML30	TL10	TL20	TL40	ZR10
LNMM151008	0.590	0.394	0.394	0.031						●			●	

Straight ramping

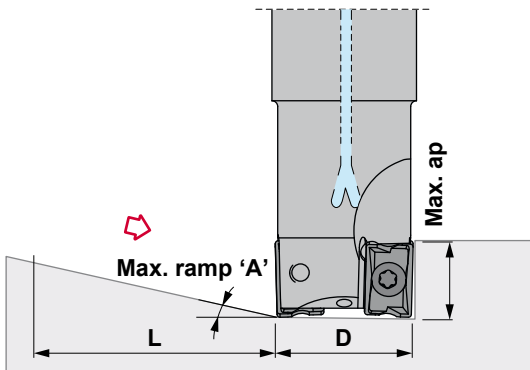

Helical ramping

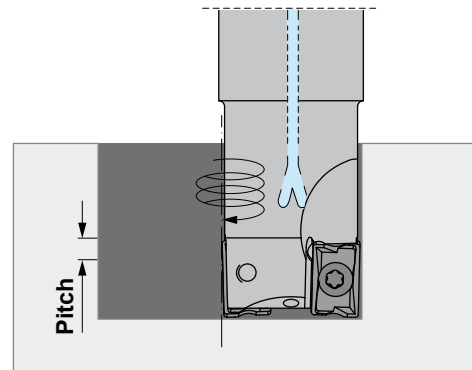

Ramping data for facing square shoulder cutters (123237 / 123293)

Cutter dia. (D)	Straight ramp down			Helical ramp down		
	Max. ramp (A°)	Max. ap	Min. length (L)	Min. dia.	Max. dia.	Max. pitch/rev.
Ø 1.250	1.2	.550	28.190	1.730		.030
					2.520	.070
Ø 1.500	0.9	.550	37.600	2.365		.030
					3.150	.065
Ø 2.000	0.8	.550	42.325	3.150		.045
					3.940	.075
Ø 2.500	0.6	.550	56.420	4.175		.050
					4.960	.070
Ø 3.000	0.45	.550	75.240	5.510		.050
					6.300	.065

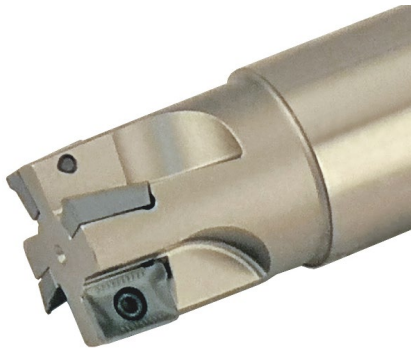

**Characteristics:**

Positive milling cutter for diversified manufacture with an exact angle of 90° that uses very strong inserts allowing deep passes and high feed per teeth. Recommended for conventional milling machines and machining centers.

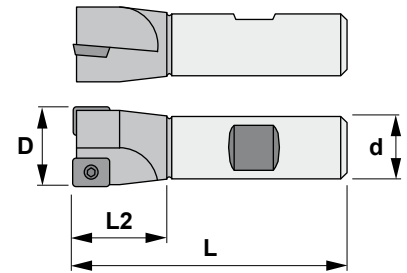
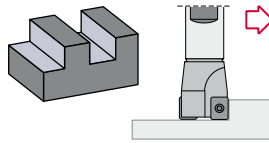

122021 90°

Reference		D	L	L2	d	Insert size			Nm	
1220210062	2	0.625	3.250	1.000	0.625	AP..1003..	1425	5507	0.9	0.440
1220210075	3	0.750	3.500	1.250	0.750	AP..1003..	1425	5507	0.9	0.440
1220210100	4	1.000	3.500	1.250	1.000	AP..1003..	1225	5507	0.9	0.770
1220210125	5	1.250	3.750	1.250	1.000	AP..1003..	1225	5507	0.9	0.965
1220210150	6	1.500	4.000	1.250	1.250	AP..1003..	1225	5507	0.9	1.590

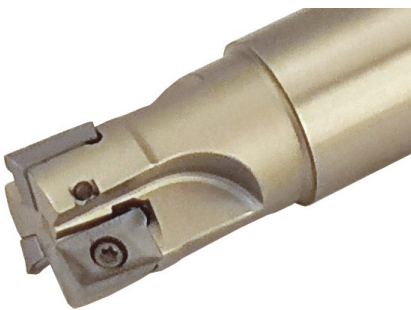
**Characteristics:**

Positive milling cutter for diversified manufacture with an exact angle of 90° that uses very strong inserts allowing deep passes and high feed per teeth. Recommended for conventional milling machines and machining centers.

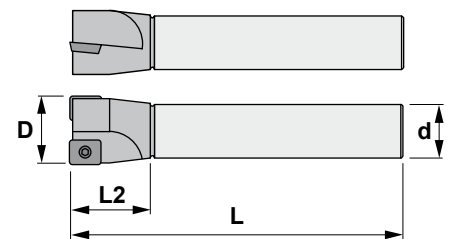
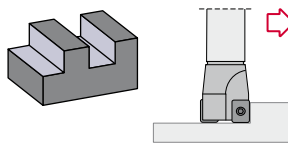

Long series

122022 90°

Reference		D	L	L2	d	Insert size			Nm	
1220220062	2	0.625	6.000	1.000	0.625	AP..1003..	1425	5507	0.9	0.680
1220220075	3	0.750	8.000	1.250	0.750	AP..1003..	1425	5507	0.9	1.000
1220220100	4	1.000	8.000	1.250	1.000	AP..1003..	1225	5507	0.9	1.730
1220220125	5	1.250	10.000	1.250	1.000	AP..1003..	1225	5507	0.9	2.300
1220220150	6	1.500	10.000	1.250	1.250	AP..1003..	1225	5507	0.9	3.700

Parallelogram inserts / Positive

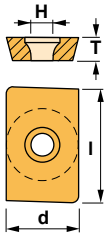

USE CLASSIFICATION

- Continuous
- Slight interruption
- ⊕ Interruption

AVAILABILITY

- Standard item
- Check availability

P Steel	●	⊕	●	⊕	●	⊕	●	⊕	●	⊕
M Stainless	●	●	●	●	●	●	●	●	●	●
K Cast iron	●	⊕	⊕	⊕	⊕	⊕	⊕	⊕	⊕	⊕
N Non ferrous materials	⊕	⊕	⊕	⊕	⊕	⊕	⊕	⊕	⊕	⊕
S Heat-resistant alloys	●	●	●	●	●	●	●	●	●	●
H Hard materials	●	●	●	●	●	●	●	●	●	●



APHT-AL



Reference	l	T	d	r	H	KM15	PM25	PM40	TIN21	TIN25	TIN28	TL10	TL20	TL40	ZR10
APHT1003PDFR-AL	0.375	0.125	0.250	-	0.110	●									●



APKT



Reference	l	T	d	r	H	KM15	PM25	PM40	TIN21	TIN25	TIN28	TL10	TL20	TL40	ZR10
APKT1003PDR	0.375	0.125	0.250	0.016	0.110						●				
APKT1003PDTR	0.375	0.125	0.250	0.016	0.110	●			●	●					

Ramping data for facing square shoulder cutters (122021 / 122022)

Cutter dia. (D)	Straight ramp down			Helical ramp down		
	Max. ramp (A°)	Max. ap	Min. length (L)	Min. dia.	Max. dia.	Max. pitch/rev.
Ø 0.625	12.5	.350	2.125	.690		.020
					1.250	.375
Ø 0.750	6.8	.350	3.980	.980		.065
					1.575	.250
Ø 1.000	8.0	.350	3.340	1.375		.145
					1.970	.370
Ø 1.250	5.0	.350	5.395	1.925		.150
					2.520	.295
Ø 1.500	3.5	.350	7.715	2.555		.160
					3.150	.255



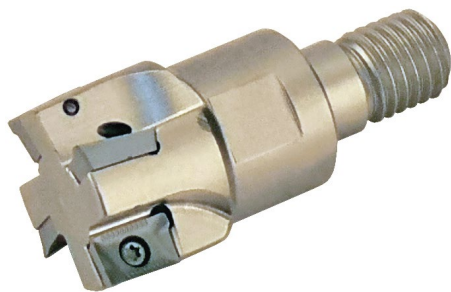

Characteristics:
Positive milling cutter for diversified manufacture with an exact angle of 90° that uses very strong inserts allowing deep passes and high feed per teeth. Recommended for conventional milling machines and machining centers.

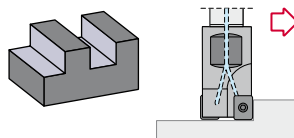
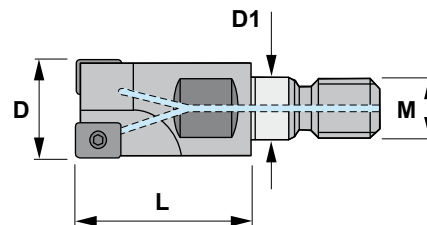

122006 90°

Reference		D	L	M	D1	Insert size	
1220060062	2	0.625	0.905	M8	0.335	AP..1003..	0.090
1220060075	3	0.750	1.181	M10	0.413	AP..1003..	0.155
1220060100	3	1.000	1.378	M12	0.492	AP..1003..	0.240

WARNING!! Modular Extensions (Pages F07 to F13).

Reference			Nm
1220060062	1425	5507	0.9
1220060075	1225	5507	0.9
1220060100	1225	5507	0.9

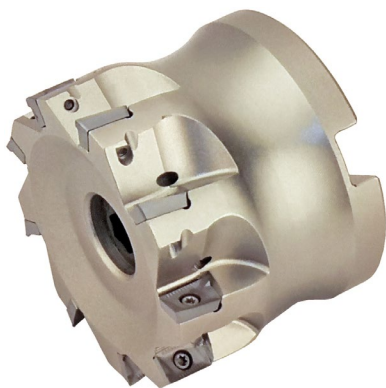

Characteristics:
Positive multi-tooth milling cutter for diversified manufacture with an exact angle of 90° that uses very strong inserts allowing deep passes and high feed per teeth. Recommended for conventional milling machines and machining centers.

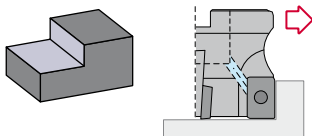
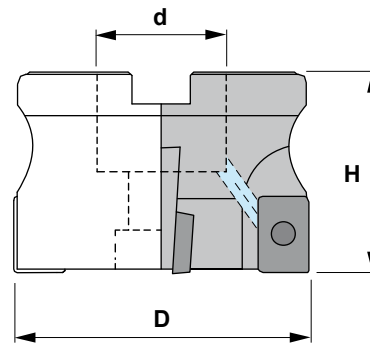

122093 90°

Reference		D	H	d	Insert size	
1220930150	6	1.500	1.750	0.500	AP..1003..	0.530
1220930200	7	2.000	1.750	0.750	AP..1003..	0.880
1220930250	9	2.500	2.000	1.000	AP..1003..	1.980

Reference				Nm
1220930150	1425	5507	UNF.14	0.9
1220930200	1225	5507	UNF.38	0.9
1220930250	1225	5507	UNF.12	0.9



Parallelogram inserts / Positive

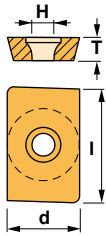

USE CLASSIFICATION

- Continuous
- ◐ Slight interruption
- ✚ Interruption

AVAILABILITY

- Standard item
- Check availability

P Steel	●	✚	●	✚	●	●	✚
M Stainless	●	●	●	●	●	●	●
K Cast iron	●	✚	✚	✚	●	✚	●
N Non ferrous materials	✚	●	●	●	●	●	✚
S Heat-resistant alloys	●	●	●	●	●	●	●
H Hard materials	●	●	●	●	●	●	●



APHT-AL



Reference	l	T	d	r	H	KM15	PM25	PM40	TIN21	TIN25	TIN28	TL10	TL20	TL40	ZR10
APHT1003PDFR-AL	0.375	0.125	0.250	-	0.110	●									●



APKT



Reference	l	T	d	r	H	KM15	PM25	PM40	TIN21	TIN25	TIN28	TL10	TL20	TL40	ZR10
APKT1003PDR	0.375	0.125	0.250	0.016	0.110						●				
APKT1003PDTR	0.375	0.125	0.250	0.016	0.110	●			●	●					

Ramping data for facing square shoulder cutters (122006 / 122093)

Cutter dia. (D)	Straight ramp down			Helical ramp down		
	Max. ramp (A°)	Max. ap	Min. length (L)	Min. dia.	Max. dia.	Max. pitch/rev.
Ø 0.625	12.5	.350	2.125	.690		.020
					1.250	.375
Ø 0.750	6.8	.350	3.980	.980		.065
					1.575	.250
Ø 1.000	8.0	.350	3.340	1.375		.145
					1.970	.370
Ø 1.500	3.5	.350	7.715	2.555		.160
					3.150	.255
Ø 2.000	2.5	.350	10.825	3.340		.190
					3.940	.230
Ø 2.500	1.7	.350	15.950	4.370		.180
					4.960	.200

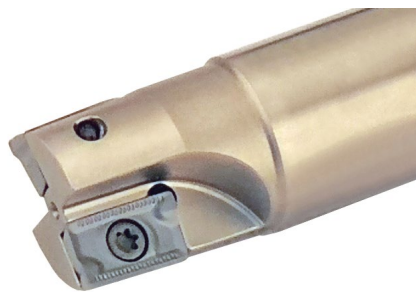

**Characteristics:**

Positive multi-tooth milling cutter for diversified manufacture with an exact angle of 90° that uses very strong inserts allowing deep passes and high feed per teeth.

Recommended for conventional milling machines and machining centers.

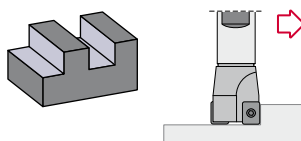
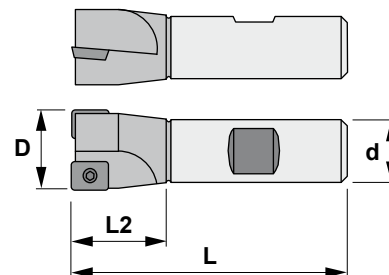

123021 90°

Reference		D	L	L2	d	Insert size			Nm	
1230210075	1	0.750	3.500	1.250	0.750	AP..1604..	1440	5515	3.0	0.440
1230210100	2	1.000	3.500	1.250	1.000	AP..1604..	1440	5515	3.0	0.770
1230210125	3	1.250	3.750	1.250	1.000	AP..1604..	1240	5515	3.0	1.320
1230210150	4	1.500	4.000	1.250	1.250	AP..1604..	1240	5515	3.0	1.430

**Characteristics:**

Positive multi-tooth milling cutter for diversified manufacture with an exact angle of 90° that uses very strong inserts allowing deep passes and high feed per teeth.

Recommended for conventional milling machines and machining centers.

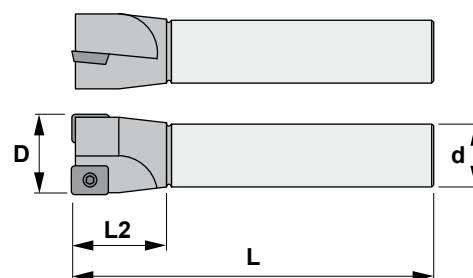

Long series

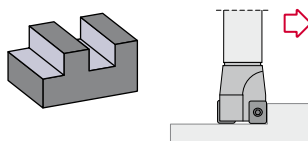

123022 90°

Reference		D	L	L2	d	Insert size			Nm	
1230220075	1	0.750	8.000	1.250	0.750	AP..1604..	1440	5515	3.0	0.440
1230220100	2	1.000	8.000	1.250	1.000	AP..1604..	1440	5515	3.0	0.770
1230220125	3	1.250	10.000	1.250	1.000	AP..1604..	1240	5515	3.0	1.320
1230220150	4	1.500	10.000	1.250	1.250	AP..1604..	1240	5515	3.0	1.430

Parallelogram inserts / Positive

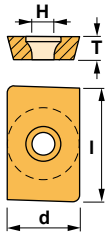

USE CLASSIFICATION

- Continuous
- Slight interruption
- ⊕ Interruption

AVAILABILITY

- Standard item
- Check availability

P Steel	●	⊕	●	⊕	●	●	⊕
M Stainless	●	●	●	⊕	●	●	●
K Cast iron	●	⊕	⊕	●	●	●	●
N Non ferrous materials	⊕	●	●	●	●	●	⊕
S Heat-resistant alloys	●	●	●	●	●	●	●
H Hard materials	●	●	●	●	●	●	●



APHT-AL



Reference	l	T	d	r	H	KM15	PM25	PM40	TIN21	TIN25	TIN28	TL10	TL20	TL40	ZR10
APHT1604PDFR-AL	0.669	0.187	0.375	-	0.110	●									●



APKT



Reference	l	T	d	r	H	KM15	PM25	PM40	TIN21	TIN25	TIN28	TL10	TL20	TL40	ZR10
APKT1604PDR	0.630	0.187	0.375	0.031	0.110		●		●	●	●				
APKT160416	0.630	0.187	0.375	0.060	0.110					●	●				
APKT160424	0.630	0.187	0.375	0.094	0.173					●					
APKT160432	0.630	0.187	0.375	0.125	0.173					●					



APMT



Reference	l	T	d	r	H	KM15	PM25	PM40	TIN21	TIN25	TIN28	TL10	TL20	TL40	ZR10
APMT1604PDER	0.630	0.187	0.375	0.031	0.173	●	●			●				●	

Ramping data for facing square shoulder cutters (123021 / 123022)

Cutter dia. (D)	Straight ramp down			Helical ramp down		
	Max. ramp (A°)	Max. ap	Min. length (L)	Min. dia.	Max. dia.	Max. pitch/rev.
Ø 0.750	8.0	.550	4.530	.870		.030
					1.575	.295
Ø 1.000	5.0	.550	7.245	1.200		.050
					1.970	.230
Ø 1.250	9.0	.550	4.015	1.755		.210
					2.520	.530
Ø 1.500	5.0	.550	7.245	2.385		.190
					3.150	.370





Characteristics:
Positive milling cutter for diversified manufacture with an exact angle of 90° that uses very strong inserts allowing deep passes and high feed per teeth. Recommended for conventional milling machines and machining centers.

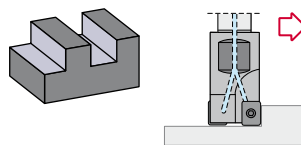
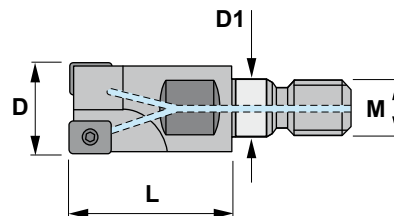

123006 90°

Reference		D	L	M	D1	Insert size			Nm	
1230060100	2	1.000	1.378	M12	0.492	AP..1604..	1440	5515	3.0	0.242
1230060125	3	1.250	1.693	M16	0.669	AP..1604..	1240	5515	3.0	0.528

WARNING!! Modular Extensions (Pages F07 to F13).

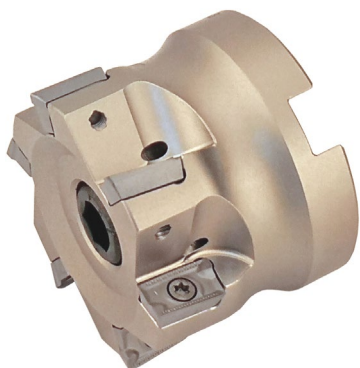

Characteristics:
Positive milling cutter for diversified manufacture with internal coolant and an exact angle of 90° that uses very strong inserts allowing deep passes and high feed per teeth. Recommended for conventional milling machines and machining centers.

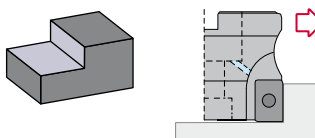
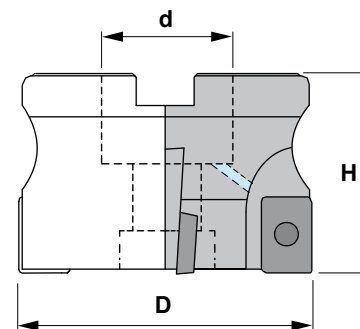

123090 90°

Reference		D	H	d	Insert size	
1230900150	4	1.500	1.750	0.500	AP..1604..	0.440
1230900200	5	2.000	1.750	0.750	AP..1604..	0.660
1230900250	6	2.500	2.000	1.000	AP..1604..	1.430
1230900300	7	3.000	2.000	1.000	AP..1604..	2.530
1230900400	8	4.000	2.000	1.250	AP..1604..	3.740
1230900500	8	5.000	2.000	1.500	AP..1604..	6.270
1230900600	9	6.000	2.000	1.500	AP..1604..	9.680

Reference					Nm
1230900150	1240	5515	-	UNF.14	3.0
1230900200	1240	5515	-	UNF.38	3.0
1230900250	1240	5515	-	UNF.12	3.0
1230900300	1240	5515	-	UNF.12	3.0
1230900400	1240	-	5615	-	3.0
1230900500	1240	-	5615	-	3.0
1230900600	1240	-	5615	-	3.0



Parallelogram inserts / Positive

	<p>USE CLASSIFICATION</p> <ul style="list-style-type: none"> ● Continuous ◐ Slight interruption ⊕ Interruption <p>AVAILABILITY</p> <ul style="list-style-type: none"> ● Standard item ○ Check availability 	P Steel	●	●	●	●	●	●	●	●	●	●	●	●	●	●	●	●	●
		M Stainless	●	●	●	●	●	●	●	●	●	●	●	●	●	●	●	●	●
		K Cast iron	●	●	●	●	●	●	●	●	●	●	●	●	●	●	●	●	●
		N Non ferrous materials	●	●	●	●	●	●	●	●	●	●	●	●	●	●	●	●	●
		S Heat-resistant alloys	●	●	●	●	●	●	●	●	●	●	●	●	●	●	●	●	●
		H Hard materials	●	●	●	●	●	●	●	●	●	●	●	●	●	●	●	●	●

	APHT-AL																			
	Reference	l	T	d	r	H	KM15	PM25	PM40	TIN21	TIN25	TIN28	TL10	TL20	TL40	ZR10				
	APHT1604PDFR-AL	0.669	0.187	0.375	-	0.110	●									●				

	APKT																			
	Reference	l	T	d	r	H	KM15	PM25	PM40	TIN21	TIN25	TIN28	TL10	TL20	TL40	ZR10				
	APKT1604PDR	0.630	0.187	0.375	0.031	0.110		●		●	●	●								
	APKT160416	0.630	0.187	0.375	0.060	0.110				●	●	●								
	APKT160424	0.630	0.187	0.375	0.094	0.173				●	●	●								
	APKT160432	0.630	0.187	0.375	0.125	0.173				●	●	●								

	APMT																			
	Reference	l	T	d	r	H	KM15	PM25	PM40	TIN21	TIN25	TIN28	TL10	TL20	TL40	ZR10				
	APMT1604PDER	0.630	0.187	0.375	0.031	0.173	●	●			●				●					

Ramping data for facing square shoulder cutters (123006 / 123093)

Cutter dia. (D)	Straight ramp down			Helical ramp down		
	Max. ramp (A°)	Max. ap	Min. length (L)	Min. dia.	Max. dia.	Max. pitch/rev.
Ø 1.000	5.0	.550	7.245	1.200		.050
					1.970	.230
Ø 1.250	9.0	.550	4.015	1.755		.210
					2.520	.530
Ø 1.500	5.0	.550	7.245	2.385		.190
					3.150	.370
Ø 2.000	4.4	.550	8.230	3.175		.250
					3.940	.405
Ø 2.500	3.2	.550	11.340	4.200		.255
					4.960	.370
Ø 3.000	2.3	.550	15.970	5.535		.255
					6.300	.340
Ø 4.000	1.8	.550	20.200	7.110		.270
					7.875	.330
Ø 5.000	1.4	.550	25.945	9.080		.270
					9.845	.320
Ø 6.000	1.0	.550	36.340	11.835		.260
					12.600	.295



Cutting data for facing square shoulder cutters

Material	P	Type of treatment	Alloy	Hardness HB
Non alloyed steel		Annealed Annealed Tempered	≤ .15% C .15% - .45% C ≥ .45% C	125 150-250 300
Low alloyed steel		Annealed Tempered Tempered		180 250-300 350
High alloyed steel		Annealed Tempered		200 350
Corrosion-resistant steel		Annealed Tempered	ferritic martensitic	200 325
Material	M	Type of treatment	Alloy	Hardness HB
Stainless steel		Annealed Quenched Quenched Hardened	ferritic / martensitic austenitic duplex martensitic / austenitic	200 180 230-260 330
Material	K	Type of treatment	Alloy	Hardness HB
Gray cast iron			pearlitic / ferritic pearlitic / martensitic	180 260
Spheroidal cast iron			ferritic pearlitic	160 -
Malleable cast iron			ferritic pearlitic	130 230
Material	N	Type of treatment	Alloy	Hardness HB
Aluminium wrought alloys		Non hardened Hardened		60 100
Aluminium cast alloys		Non hardened Hardened Non hardened	< 12% Si < 12% Si < 12% Si	80 90 130
Copper and copper alloys (bronze, brass)			machining alloy stock (1% Pb) brass, red bronze bronze lead-free copper and electrolytic copper	- 90 100 100
Non-metallic materials			thermosetting plastics fiber-reinforced plastics hard rubber	- - -
Material	S	Type of treatment	Alloy	Hardness HB
Heat-resistant alloys		Annealed Hardened Annealed Hardened Cast	Fe-base Fe-base Ni or Co-base Ni or Co-base 30 - 58 HRC Ni or Co-base 1500 - 2200 N/mm ²	200 280 250 - -
Titanium alloys			pure titanium alpha + beta alloys	R _m 440* R _m 1050*
Material	H	Type of treatment	Alloy	Hardness HB
Tempered steel		Hardened and tempered Hardened and tempered		55 HRC 60 HRC
Chilled castings		Cast		400
Tempered cast iron		Hardened and tempered		55 HRC

* R_m = ultimate tensile strength, measured in MPa

Uncoated carbide				Coated carbide							
KM15		PM25		TIN21		TIN25		TIN28		TL40	
⊘ V _c (sfm)	↗ V _c (sfm)	⊘ V _c (sfm)	↗ V _c (sfm)	⊘ V _c (sfm)	↗ V _c (sfm)	⊘ V _c (sfm)	↗ V _c (sfm)	⊘ V _c (sfm)	↗ V _c (sfm)	⊘ V _c (sfm)	↗ V _c (sfm)
-	-	252-722	328-525	689-1148	427-656	328-722	230-590	492-853	295-590	656-919	427-689
-	-	328-459	295-492	558-1050	361-591	328-722	230-590	492-853	295-590	558-820	361-591
-	-	394-591	262-459	492-919	295-492	328-722	230-590	492-853	295-590	492-722	295-492
-	-	394-591	262-459	429-820	262-459	328-722	230-558	262-722	230-525	459-656	262-459
-	-	361-558	262-459	459-689	197-394	328-722	230-558	262-722	230-525	427-591	197-427
-	-	328-525	230-361	328-591	197-361	328-722	230-558	262-722	230-525	328-525	197-361
-	-	328-525	197-328	459-689	197-361	262-590	197-459	295-590	230-459	328-525	197-361
-	-	295-492	197-328	328-558	197-361	262-590	197-459	295-590	230-459	295-459	197-328
-	-	-	-	459-623	262-459	262-590	197-459	230-590	197-459	427-591	262-459
-	-	-	-	328-558	230-394	262-590	197-459	230-590	197-459	295-492	230-427

Uncoated carbide				Coated carbide							
KM15		PM25		TIN21		TIN25		TIN28		TL40	
⊘ V _c (sfm)	↗ V _c (sfm)	⊘ V _c (sfm)	↗ V _c (sfm)	⊘ V _c (sfm)	↗ V _c (sfm)	⊘ V _c (sfm)	↗ V _c (sfm)	⊘ V _c (sfm)	↗ V _c (sfm)	⊘ V _c (sfm)	↗ V _c (sfm)
-	-	-	-	361-656	-	197-656	131-459	197-656	197-459	-	230-459
-	-	-	-	394-689	-	197-656	131-459	197-656	197-459	-	230-427
-	-	-	-	-	-	197-656	131-459	197-656	197-459	-	197-361
-	-	-	-	262-459	-	197-656	131-459	197-656	197-459	-	230-427

Uncoated carbide				Coated carbide							
KM15		PM25		TIN21		TIN25		TIN28		TL40	
⊘ V _c (sfm)	↗ V _c (sfm)	⊘ V _c (sfm)	↗ V _c (sfm)	⊘ V _c (sfm)	↗ V _c (sfm)	⊘ V _c (sfm)	↗ V _c (sfm)	⊘ V _c (sfm)	↗ V _c (sfm)	⊘ V _c (sfm)	↗ V _c (sfm)
295-525	295-525	-	-	525-722	394-591	-	-	-	-	-	-
262-427	262-427	-	-	328-558	262-492	-	-	-	-	-	-
328-525	328-525	-	-	328-656	262-558	-	-	-	-	-	-
295-492	295-492	-	-	295-591	230-459	-	-	-	-	-	-
328-525	328-525	-	-	295-591	230-459	-	-	-	-	-	-
230-492	230-492	-	-	262-525	230-426	-	-	-	-	-	-

Uncoated carbide				Coated carbide							
KM15		PM25		TIN21		TIN25		TIN28		TL40	
⊘ V _c (sfm)	↗ V _c (sfm)	⊘ V _c (sfm)	↗ V _c (sfm)	⊘ V _c (sfm)	↗ V _c (sfm)	⊘ V _c (sfm)	↗ V _c (sfm)	⊘ V _c (sfm)	↗ V _c (sfm)	⊘ V _c (sfm)	↗ V _c (sfm)
-	656-9842	-	-	-	-	-	-	-	-	-	-
-	656-6562	-	-	-	-	-	-	-	-	-	-
-	656-6562	-	-	-	-	-	-	-	-	-	-
-	656-5905	-	-	-	-	-	-	-	-	-	-
-	656-3281	-	-	-	-	-	-	-	-	-	-
-	656-1968	-	-	-	-	-	-	-	-	-	-
820-3281	820-3281	-	-	-	-	-	-	-	-	-	-
-	492-1312	-	-	-	-	-	-	-	-	-	-
-	984-2625	-	-	-	-	-	-	-	-	-	-
262-3281	262-3281	-	-	-	-	-	-	-	-	-	-
230-1640	230-1640	-	-	-	-	-	-	-	-	-	-
262-984	262-984	-	-	-	-	-	-	-	-	-	-

Uncoated carbide				Coated carbide							
KM15		PM25		TIN21		TIN25		TIN28		TL40	
⊘ V _c (sfm)	↗ V _c (sfm)	⊘ V _c (sfm)	↗ V _c (sfm)	⊘ V _c (sfm)	↗ V _c (sfm)	⊘ V _c (sfm)	↗ V _c (sfm)	⊘ V _c (sfm)	↗ V _c (sfm)	⊘ V _c (sfm)	↗ V _c (sfm)
-	-	-	-	-	197-295	-	-	-	66-197	-	197-328
-	-	-	-	-	197-295	-	-	-	66-197	-	197-328
-	-	-	-	-	-	-	-	-	66-197	-	164-262
-	-	-	-	-	-	-	-	-	66-98	-	131-246
-	-	-	-	-	-	-	-	-	66-98	-	148-246
-	-	-	-	-	-	-	-	-	131-230	-	66-1310
-	-	-	-	-	-	-	-	-	66-131	-	-

Uncoated carbide				Coated carbide							
KM15		PM25		TIN21		TIN25		TIN28		TL40	
⊘ V _c (sfm)	↗ V _c (sfm)	⊘ V _c (sfm)	↗ V _c (sfm)	⊘ V _c (sfm)	↗ V _c (sfm)	⊘ V _c (sfm)	↗ V _c (sfm)	⊘ V _c (sfm)	↗ V _c (sfm)	⊘ V _c (sfm)	↗ V _c (sfm)
-	-	-	-	-	-	-	-	-	-	-	-
-	-	-	-	-	-	-	-	-	-	-	-
-	-	-	-	230-427	-	-	-	-	-	-	-
-	-	-	-	-	-	-	-	-	-	-	-



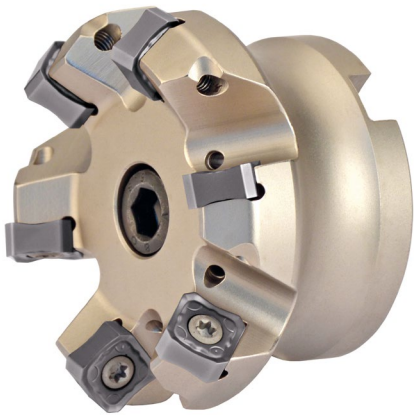

Characteristics:

Super positive milling cutter with 45° entering angle that decreases cutting forces and allows a quick feed in a limited capacity machine. It works well on hard steels, alloyed steels, stainless steels, refractory casts and aluminium alloys.

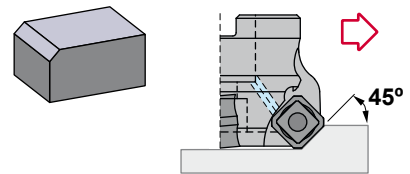
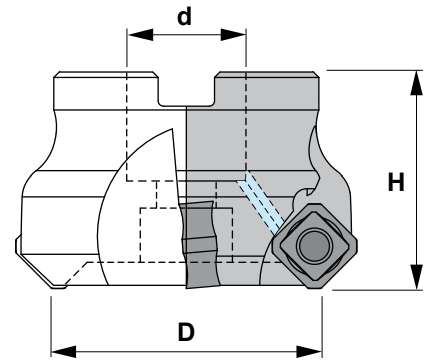

174293 45°

Reference		D	H	d	Insert size	
1742930200	4	2.000	1.750	0.750	SNMX1206..	0.770
1742930250	6	2.500	2.000	1.000	SNMX1206..	1.765
1742930300	7	3.000	2.000	1.000	SNMX1206..	2.535
1742930400	8	4.000	2.000	1.250	SNMX1206..	3.750
1742930500	10	5.000	2.500	1.500	SNMX1206..	6.065

Reference					Nm
1742930200	1550	5520	-	UNF.38	4.0
1742930250	1550	5520	-	UNF.12	4.0
1742930300	1550	5520	-	UNF.12	4.0
1742930400	1550	-	5620	-	4.0
1742930500	1550	-	5620	-	4.0

SNMX

Square negative insert. G12

Reference	l	T	a
SNMX1206..	0.500	0.250	0.093

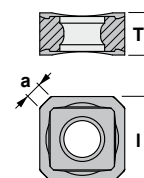

SNMX



Square inserts / Negative

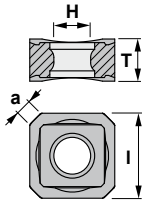

i USE CLASSIFICATION

- Continuous
- ◐ Slight interruption
- ⊕ Interruption

i AVAILABILITY

- Standard item
- Check availability

P Steel	●	⊕	●	⊕	●	⊕	●	⊕	●	⊕
M Stainless	●	●	●	●	●	●	●	●	●	●
K Cast iron	●	⊕	⊕	⊕	⊕	⊕	⊕	⊕	⊕	⊕
N Non ferrous materials	⊕	⊕	⊕	⊕	⊕	⊕	⊕	⊕	⊕	⊕
S Heat-resistant alloys										
H Hard materials										



SNMX

Reference	l	T	a	KM15	PM25	PM40	TIN21	TIN25	ML30	TL10	TL20	TL40	ZR10
SNMX1206ANSN	0.500	0.250	0.093						●			●	



G

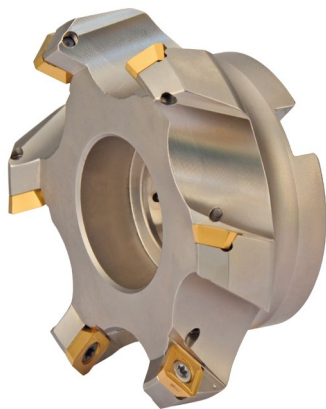

Characteristics:

Super positive face milling cutter with 45° entering angle that decreases cutting forces and allows a quick feed in a limited capacity machine.

It works well on steels, stainless steel, alloyed steels, cast iron and aluminium alloys.

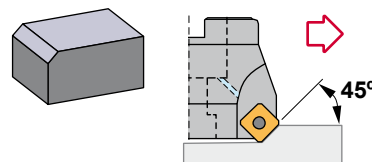
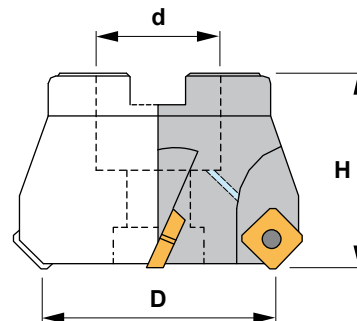

174890 45°

Reference		D	H	d	Insert size	
1748900200	4	2.000	1.750	0.750	SE..1204..	0.770
1748900250	5	2.500	2.000	1.000	SE..1204..	1.760
1748900300	6	3.000	2.000	1.000	SE..1204..	2.530
1748900400	6	4.000	2.000	1.250	SE..1204..	3.740
1748900500	7	5.000	2.000	1.500	SE..1204..	6.050
1748900600	8	6.000	2.000	1.500	SE..1204..	10.120
1748900800	10	8.000	2.500	2.500	SE..1204..	14.520

Reference						Nm
1748900200	1550	5520	-	UNF.38	-	4.0
1748900250	1550	5520	-	UNF.12	-	4.0
1748900300	1550	5520	-	UNF.12	-	4.0
1748900400	1550	-	5620	-	-	4.0
1748900500	1550	-	5620	-	-	4.0
1748900600	1550	-	5620	-	40	4.0
1748900800	1550	-	5620	UNF.34	50	4.0

SE..

Square positive inserts with 20° clearance. G11

Reference	l	T	d
SEH..1204..	0.500	0.187	0.500
SEMT1204..	0.500	0.187	0.500

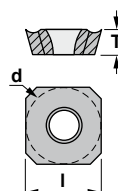

SEHT



SEHT-AL



SEHW



SEMT



Square inserts / Positive

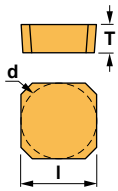

USE CLASSIFICATION

- Continuous
- ◐ Slight interruption
- ✚ Interruption

AVAILABILITY

- Standard item
- Check availability

P Steel	●	✚	●	✚	●	●	●	●	●	●	●	●	●	●	●	●	●	●	●	●
M Stainless	●	●	●	●	●	●	●	●	●	●	●	●	●	●	●	●	●	●	●	●
K Cast iron	●	✚	●	✚	●	●	●	●	●	●	●	●	●	●	●	●	●	●	●	●
N Non ferrous materials	●	●	●	●	●	●	●	●	●	●	●	●	●	●	●	●	●	●	●	●
S Heat-resistant alloys	●	●	●	●	●	●	●	●	●	●	●	●	●	●	●	●	●	●	●	●
H Hard materials	●	●	●	●	●	●	●	●	●	●	●	●	●	●	●	●	●	●	●	●



SEHT



Reference	l	T	d	H
SEHT43AFN	0.500	0.187	0.500	0.203

●	●	●	●	●	●	●	●	●	●	●	●	●	●	●	●	●	●	●	●	●



SEHT-AL



Reference	l	T	d	H
SEHT1204AFFN-AL	0.500	0.125	0.500	0.203

●	●	●	●	●	●	●	●	●	●	●	●	●	●	●	●	●	●	●	●	●



SEHW



Reference	l	T	d	H
SEHW43AFEN001	0.500	0.187	0.500	0.203
SEHW43AFSN151	0.500	0.187	0.500	0.203

●	●	●	●	●	●	●	●	●	●	●	●	●	●	●	●	●	●	●	●	●



SEMT



Reference	l	T	d
SEMT1204AFTN	0.500	0.187	0.500

●	●	●	●	●	●	●	●	●	●	●	●	●	●	●	●	●	●	●	●	●



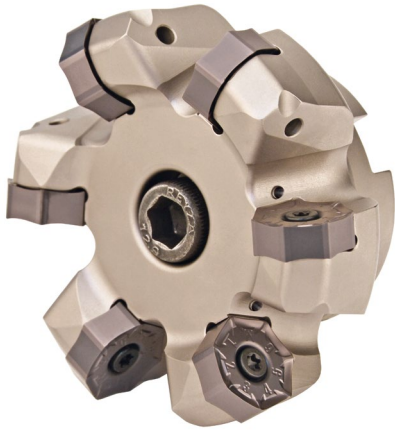

Characteristics:

Positive face chamfering milling cutter with 45° entering angle that decreases cutting forces and allows a quick feed in a limited capacity machine.

It works well on steels, stainless steel, alloyed steels, cast iron and aluminium alloys.

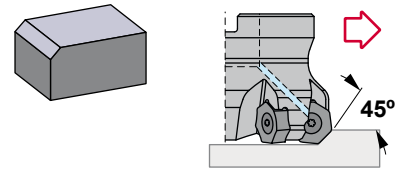
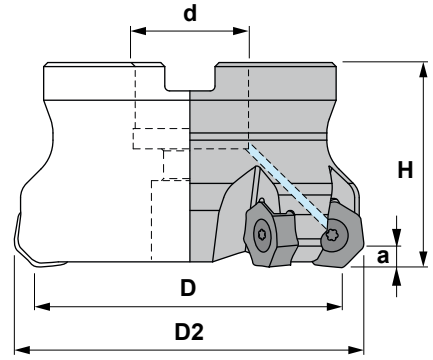

185293 45°

Reference		D	D2	H	d	a	Insert size	
1852930250	5	2.500	2.994	2.000	0.750	0.236	NNMU2007..	1.765
1852930300	6	3.000	3.494	2.000	1.000	0.236	NNMU2007..	2.540
1852930400	7	4.000	4.494	2.000	1.250	0.236	NNMU2007..	3.750

Reference					Nm
1852930250	1250	5520	-	UNF.38	4.0
1852930300	1250	5520	-	-	4.0
1852930400	1250	-	5620	-	4.0

NNMU

Heptagonal positive insert with 15° clearance. G09

Reference	I	T	d
NNMU2007..	0.323	0.285	0.787

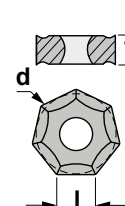

NNMU



Heptagonal inserts / Negative

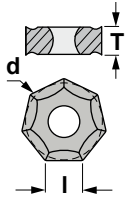

i USE CLASSIFICATION

- Continuous
- ◐ Slight interruption
- ⊕ Interruption

i AVAILABILITY

- Standard item
- Check availability

P Steel	●	⊕	⊕	⊕	⊕	⊕	⊕	⊕	⊕	⊕	⊕	⊕	⊕
M Stainless	●	⊕	⊕	⊕	⊕	⊕	⊕	⊕	⊕	⊕	⊕	⊕	⊕
K Cast iron	●	⊕	⊕	⊕	⊕	⊕	⊕	⊕	⊕	⊕	⊕	⊕	⊕
N Non ferrous materials	●	⊕	⊕	⊕	⊕	⊕	⊕	⊕	⊕	⊕	⊕	⊕	⊕
S Heat-resistant alloys	●	⊕	⊕	⊕	⊕	⊕	⊕	⊕	⊕	⊕	⊕	⊕	⊕
H Hard materials	●	⊕	⊕	⊕	⊕	⊕	⊕	⊕	⊕	⊕	⊕	⊕	⊕



NNMU

Reference	l	T	d	KM15	PM25	PM40	TIN21	TIN25	ML30	TL10	TL20	TL40	ZR10
NNMU200708	0.323	0.285	0.787						●			●	



G

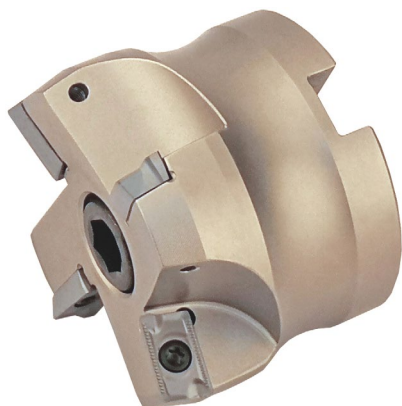

Characteristics:

Positive milling cutter with 75° entering angle.

Recommended for manual machines as well as for C.N.C. machines.

It allows to use the edges of APMT and APKT inserts that are not used currently.

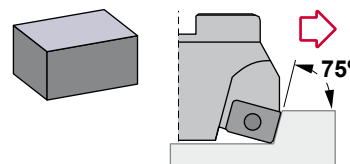
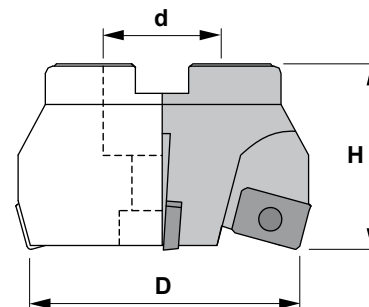

143090 75°

Reference		D	H	d	Insert size	
1430900200	3	2.000	1.750	0.750	AP..1604..	0.770
1430900250	4	2.500	2.000	1.000	AP..1604..	1.540
1430900300	5	3.000	2.000	1.000	AP..1604..	2.420
1430900400	6	4.000	2.000	1.250	AP..1604..	4.180

Reference					Nm
1430900200	1240	5515	-	UNF.38	3.0
1430900250	1240	5515	-	UNF.12	3.0
1430900300	1240	5515	-	UNF.12	3.0
1430900400	1240	-	5615	-	3.0

AP..

Parallelogram positive inserts with 11° clearance. G07

Reference	l	T	d
AP..1604..	0.630	0.187	0.375

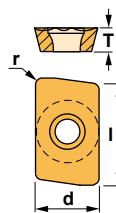

APHT-AL



APKT



APMT



-AL

Aluminium



- Excellent thermal crack resistance makes it possible to machine in wet cutting conditions.
- Cemented carbide can be applied for various workpieces.
- High toughness and low cutting force.
- Low affinity to workpiece.

This geometry can be used for turning aluminium, light alloys, non ferrous materials, high-melting metals, plastics, glass fiber, reinforced plastics, laminated board, carbon and fine ceramics.

Main application area: Cutting depth (Ap): 0.039 - 0.393 inch.
Feed (f): 0.004 - 0.029 inch.

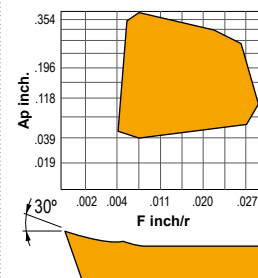

G07

Parallelogram inserts / Positive

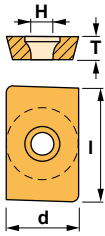

USE CLASSIFICATION

- Continuous
- ◐ Slight interruption
- ✚ Interruption

AVAILABILITY

- Standard item
- Check availability

P Steel	●	✚	●	✚	●	✚	●	✚	●	✚
M Stainless	●	●	●	●	●	●	●	●	●	●
K Cast iron	●	✚	✚	✚	✚	✚	✚	✚	✚	✚
N Non ferrous materials	✚	●	●	●	●	●	●	●	●	✚
S Heat-resistant alloys	●	●	●	●	●	●	●	●	●	●
H Hard materials	●	●	●	●	●	●	●	●	●	●



APHT-AL



Reference	l	T	d	r	H	KM15	PM25	PM40	TIN21	TIN25	TIN28	TL10	TL20	TL40	ZR10
APHT1604PDFR-AL	0.669	0.187	0.375	-	0.110	●									●

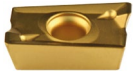

APKT



Reference	l	T	d	r	H	KM15	PM25	PM40	TIN21	TIN25	TIN28	TL10	TL20	TL40	ZR10
APKT1604PDR	0.630	0.187	0.375	0.031	0.110		●		●	●	●				
APKT160416	0.630	0.187	0.375	0.060	0.110					●	●				
APKT160424	0.630	0.187	0.375	0.094	0.173					●					
APKT160432	0.630	0.187	0.375	0.125	0.173					●					



APMT



Reference	l	T	d	r	H	KM15	PM25	PM40	TIN21	TIN25	TIN28	TL10	TL20	TL40	ZR10
APMT1604PDER	0.630	0.187	0.375	0.031	0.173	●	●			●				●	



G

Cutting data for face milling cutters

Material	P	Type of treatment	Alloy	Hardness HB
Non alloyed steel		Annealed Annealed Tempered	≤ .15% C .15% - .45% C ≥ .45% C	125 150-250 300
Low alloyed steel		Annealed Tempered Tempered		180 250-300 350
High alloyed steel		Annealed Tempered		200 350
Corrosion-resistant steel		Annealed Tempered	ferritic martensitic	200 325
Material	M	Type of treatment	Alloy	Hardness HB
Stainless steel		Annealed Quenched Quenched Hardened	ferritic / martensitic austenitic duplex martensitic / austenitic	200 180 230-260 330
Material	K	Type of treatment	Alloy	Hardness HB
Gray cast iron			pearlitic / ferritic pearlitic / martensitic	180 260
Spheroidal cast iron			ferritic pearlitic	160 -
Malleable cast iron			ferritic pearlitic	130 230
Material	N	Type of treatment	Alloy	Hardness HB
Aluminium wrought alloys		Non hardened Hardened		60 100
Aluminium cast alloys		Non hardened Hardened Non hardened	< 12% Si < 12% Si < 12% Si	80 90 130
Copper and copper alloys (bronze, brass)			machining alloy stock (1% Pb) brass, red bronze bronze lead-free copper and electrolytic copper	- 90 100 100
Non-metallic materials			thermosetting plastics fiber-reinforced plastics hard rubber	- - -
Material	S	Type of treatment	Alloy	Hardness HB
Heat-resistant alloys		Annealed Hardened Annealed Hardened Cast	Fe-base Fe-base Ni or Co-base Ni or Co-base 30 - 58 HRC Ni or Co-base 1500 - 2200 N/mm ²	200 280 250 - -
Titanium alloys			pure titanium alpha + beta alloys	R _m 440* R _m 1050*
Material	H	Type of treatment	Alloy	Hardness HB
Tempered steel		Hardened and tempered Hardened and tempered		55 HRC 60 HRC
Chilled castings		Cast		400
Tempered cast iron		Hardened and tempered		55 HRC

* R_m = ultimate tensile strength, measured in MPa

Uncoated carbide				Coated carbide							
KM15		PM25		TIN21		TIN25		TIN28		TL40	
⊘ V _c (sfm)	↗ V _c (sfm)	⊘ V _c (sfm)	↗ V _c (sfm)	⊘ V _c (sfm)	↗ V _c (sfm)	⊘ V _c (sfm)	↗ V _c (sfm)	⊘ V _c (sfm)	↗ V _c (sfm)	⊘ V _c (sfm)	↗ V _c (sfm)
-	-	252-722	328-525	689-1148	427-656	328-722	230-590	492-853	295-590	656-919	427-689
-	-	328-459	295-492	558-1050	361-591	328-722	230-590	492-853	295-590	558-820	361-591
-	-	394-591	262-459	492-919	295-492	328-722	230-590	492-853	295-590	492-722	295-492
-	-	394-591	262-459	429-820	262-459	328-722	230-558	262-722	230-525	459-656	262-459
-	-	361-558	262-459	459-689	197-394	328-722	230-558	262-722	230-525	427-591	197-427
-	-	328-525	230-361	328-591	197-361	328-722	230-558	262-722	230-525	328-525	197-361
-	-	328-525	197-328	459-689	197-361	262-590	197-459	295-590	230-459	328-525	197-361
-	-	295-492	197-328	328-558	197-361	262-590	197-459	295-590	230-459	295-459	197-328
-	-	-	-	459-623	262-459	262-590	197-459	230-590	197-459	427-591	262-459
-	-	-	-	328-558	230-394	262-590	197-459	230-590	197-459	295-492	230-427

Uncoated carbide				Coated carbide							
KM15		PM25		TIN21		TIN25		TIN28		TL40	
⊘ V _c (sfm)	↗ V _c (sfm)	⊘ V _c (sfm)	↗ V _c (sfm)	⊘ V _c (sfm)	↗ V _c (sfm)	⊘ V _c (sfm)	↗ V _c (sfm)	⊘ V _c (sfm)	↗ V _c (sfm)	⊘ V _c (sfm)	↗ V _c (sfm)
-	-	-	-	361-656	-	197-656	131-459	197-656	197-459	-	230-459
-	-	-	-	394-689	-	197-656	131-459	197-656	197-459	-	230-427
-	-	-	-	-	-	197-656	131-459	197-656	197-459	-	197-361
-	-	-	-	262-459	-	197-656	131-459	197-656	197-459	-	230-427

Uncoated carbide				Coated carbide							
KM15		PM25		TIN21		TIN25		TIN28		TL40	
⊘ V _c (sfm)	↗ V _c (sfm)	⊘ V _c (sfm)	↗ V _c (sfm)	⊘ V _c (sfm)	↗ V _c (sfm)	⊘ V _c (sfm)	↗ V _c (sfm)	⊘ V _c (sfm)	↗ V _c (sfm)	⊘ V _c (sfm)	↗ V _c (sfm)
295-525	295-525	-	-	525-722	394-591	-	-	-	-	-	-
262-427	262-427	-	-	328-558	262-492	-	-	-	-	-	-
328-525	328-525	-	-	328-656	262-558	-	-	-	-	-	-
295-492	295-492	-	-	295-591	230-459	-	-	-	-	-	-
328-525	328-525	-	-	295-591	230-459	-	-	-	-	-	-
230-492	230-492	-	-	262-525	230-426	-	-	-	-	-	-

Uncoated carbide				Coated carbide							
KM15		PM25		TIN21		TIN25		TIN28		TL40	
⊘ V _c (sfm)	↗ V _c (sfm)	⊘ V _c (sfm)	↗ V _c (sfm)	⊘ V _c (sfm)	↗ V _c (sfm)	⊘ V _c (sfm)	↗ V _c (sfm)	⊘ V _c (sfm)	↗ V _c (sfm)	⊘ V _c (sfm)	↗ V _c (sfm)
-	656-9842	-	-	-	-	-	-	-	-	-	-
-	656-6562	-	-	-	-	-	-	-	-	-	-
-	656-6562	-	-	-	-	-	-	-	-	-	-
-	656-5905	-	-	-	-	-	-	-	-	-	-
-	656-3281	-	-	-	-	-	-	-	-	-	-
-	656-1968	-	-	-	-	-	-	-	-	-	-
820-3281	820-3281	-	-	-	-	-	-	-	-	-	-
-	492-1312	-	-	-	-	-	-	-	-	-	-
-	984-2625	-	-	-	-	-	-	-	-	-	-
262-3281	262-3281	-	-	-	-	-	-	-	-	-	-
230-1640	230-1640	-	-	-	-	-	-	-	-	-	-
262-984	262-984	-	-	-	-	-	-	-	-	-	-

Uncoated carbide				Coated carbide							
KM15		PM25		TIN21		TIN25		TIN28		TL40	
⊘ V _c (sfm)	↗ V _c (sfm)	⊘ V _c (sfm)	↗ V _c (sfm)	⊘ V _c (sfm)	↗ V _c (sfm)	⊘ V _c (sfm)	↗ V _c (sfm)	⊘ V _c (sfm)	↗ V _c (sfm)	⊘ V _c (sfm)	↗ V _c (sfm)
-	-	-	-	-	197-295	-	-	-	66-197	-	197-328
-	-	-	-	-	197-295	-	-	-	66-197	-	197-328
-	-	-	-	-	-	-	-	-	66-197	-	164-262
-	-	-	-	-	-	-	-	-	66-98	-	131-246
-	-	-	-	-	-	-	-	-	66-98	-	148-246
-	-	-	-	-	-	-	-	-	131-230	-	66-1310
-	-	-	-	-	-	-	-	-	66-131	-	-

Uncoated carbide				Coated carbide							
KM15		PM25		TIN21		TIN25		TIN28		TL40	
⊘ V _c (sfm)	↗ V _c (sfm)	⊘ V _c (sfm)	↗ V _c (sfm)	⊘ V _c (sfm)	↗ V _c (sfm)	⊘ V _c (sfm)	↗ V _c (sfm)	⊘ V _c (sfm)	↗ V _c (sfm)	⊘ V _c (sfm)	↗ V _c (sfm)
-	-	-	-	-	-	-	-	-	-	-	-
-	-	-	-	-	-	-	-	-	-	-	-
-	-	-	-	230-427	-	-	-	-	-	-	-
-	-	-	-	-	-	-	-	-	-	-	-



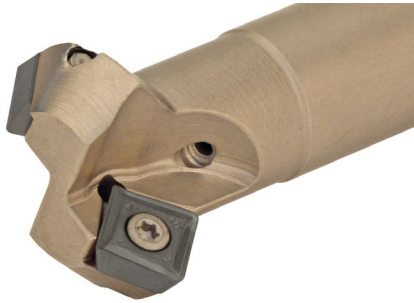

Characteristics:
 Chamfering milling cutter for diversified manufacture.
 Recommended for small conventional milling machines and machining centers.

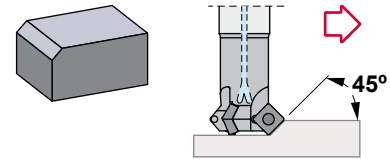
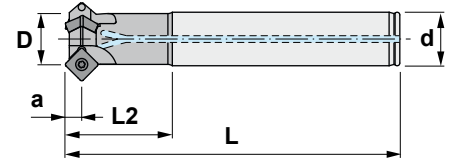

073503 45°

Reference		D	L	d	L2	a	Insert size	
0735030062	2	0.625	5.00	0.625	1.000	0.235	SDMT09T3..	0.410
0735030075	3	0.750	6.00	0.750	1.000	0.235	SDMT09T3..	0.484

Reference			Nm
0735030062	1230	5508	1.2
0735030075	1230	5508	1.2



Square inserts / Positive

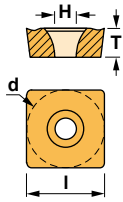

USE CLASSIFICATION

- Continuous
- ◐ Slight interruption
- ⊕ Interruption

AVAILABILITY

- Standard item
- Check availability

P Steel	●	⊕	●	⊕	●	⊕	●	⊕
M Stainless	●	●	●	⊕	●	●	●	●
K Cast iron	●	⊕	⊕	⊕	●	●	●	●
N Non ferrous materials	⊕	●	●	●	●	●	●	⊕
S Heat-resistant alloys	●	●	●	●	●	●	●	●
H Hard materials	●	●	●	●	●	●	●	●



SDMT



Reference	l	T	d	r	KM15	PM25	PM40	TIN21	TIN25	TIN28	TL10	TL20	TL40	ZR10
SDMT09T308	0.375	0.156	0.375	0.031				●					●	

Cutting data for chamfer milling cutter

Material	P	Cutting Speed Vc (sfm)	Feed rate in/tooth		
			Max. Chamfering 0.059 in	Max. Chamfering 0.098 in	Max. Chamfering 0.157 in
Carbon steel C<0.3%		492-820-1148	0.002~0.004	0.003~0.009	0.003~0.009
Carbon steel C>0.3%		656-984-1312	0.002~0.003	0.003~0.007	0.003~0.009
Low alloyed steel C<0.3%		590-787-853	0.002~0.003	0.003~0.007	0.003~0.007
High alloy steel C>0.3%		393-492-656	0.002~0.003	0.003~0.005	0.003~0.005
Material	M	Cutting Speed Vc (sfm)	Feed rate in/tooth		
			Max. Chamfering 0.059 in	Max. Chamfering 0.098 in	Max. Chamfering 0.157 in
Stainless steel		393-492-590	0.002~0.003	0.002~0.005	0.003~0.007
Material	K	Cutting Speed Vc (sfm)	Feed rate in/tooth		
			Max. Chamfering 0.059 in	Max. Chamfering 0.098 in	Max. Chamfering 0.157 in
Casting iron		393-492-590	0.002~0.003	0.003~0.005	0.003~0.007
Material	N	Cutting Speed Vc (sfm)	Feed rate in/tooth		
			Max. Chamfering 0.059 in	Max. Chamfering 0.098 in	Max. Chamfering 0.157 in
Al. and non-ferrous metal		656-1312-1968	0.002~0.005	0.003~0.009	0.003~0.009
Material	H	Cutting Speed Vc (sfm)	Feed rate in/tooth		
			Max. Chamfering 0.059 in	Max. Chamfering 0.098 in	Max. Chamfering 0.157 in
Hardened steel<50 HRC		262-295-328	0.002~0.003	0.002~0.004	0.003~0.005



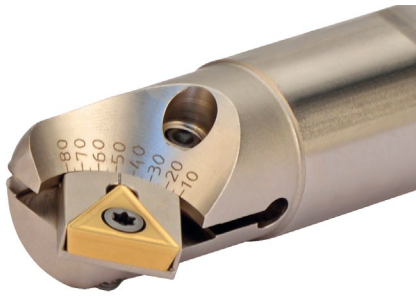

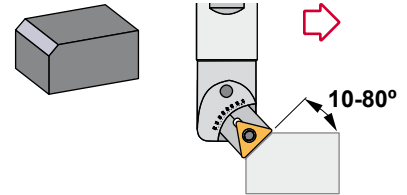
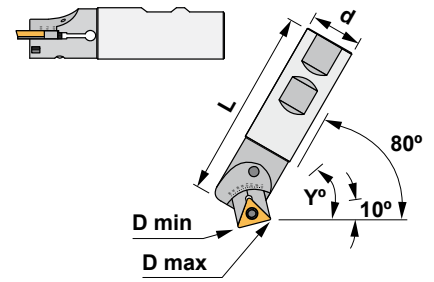

Characteristics:
Adjustable chamfering milling cutter for specific operations.
Recommended for small conventional milling machines and machining centers.



16²/₃421

Reference		d	L	Y	Dmin	Dmax	Insert size	
1624210075	1	0.750	3.937	10° - 80°	0.197	1.024	TC..21.5..	0.550
1634210100	1	0.750	3.937	10° - 80°	0.197	1.260	TC..32.5..	0.550

Reference					Nm
1624210075	6921	1225	1905	5507	0.9
1634210100	6926	1240	1296	5515	3.0



Triangular inserts / Positive

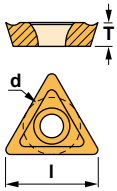

USE CLASSIFICATION

- Continuous
- ◐ Slight interruption
- ✚ Interruption

AVAILABILITY

- Standard item
- Check availability

P Steel	●	✚	●	✚	●	●	✚
M Stainless	●	●	●	✚	●	●	●
K Cast iron	●	✚	●	✚	●	●	●
N Non ferrous materials	✚	●	●	●	●	●	✚
S Heat-resistant alloys	●	●	●	●	●	●	●
H Hard materials	●	●	●	●	●	●	●



TCGT-AL



Reference	l	T	d	r	H	KM15	PM25	PM40	TIN21	TIN25	TIN28	TL10	TL20	TL40	ZR10
TCGT21.50-AL	0.433	0.094	0.250	0.008	0.110	●									○
TCGT21.51-AL	0.433	0.094	0.250	0.016	0.110	●									○
TCGT32.50-AL	0.650	0.156	0.375	0.008	0.173	●									○
TCGT32.51-AL	0.650	0.156	0.375	0.016	0.173	●									○
TCGT32.52-AL	0.650	0.156	0.375	0.031	0.173	●									○



TCMT-39



Reference	l	T	d	r	H	KM15	PM25	PM40	TIN21	TIN25	TIN28	TL10	TL20	TL40	ZR10
TCMT32.52-39	0.650	0.156	0.375	0.031	0.173	●				●				●	
TCMT32.53-39	0.650	0.156	0.375	0.047	0.173	●				●					

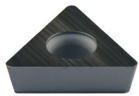

TCMW



Reference	l	T	d	r	H	KM15	PM25	PM40	TIN21	TIN25	TIN28	TL10	TL20	TL40	ZR10
TCMW21.51	0.433	0.094	0.250	0.016	0.016	○	●								
TCMW32.51	0.650	0.156	0.375	0.016	0.016	●									
TCMW32.52	0.650	0.156	0.375	0.031	0.031	●	●							○	

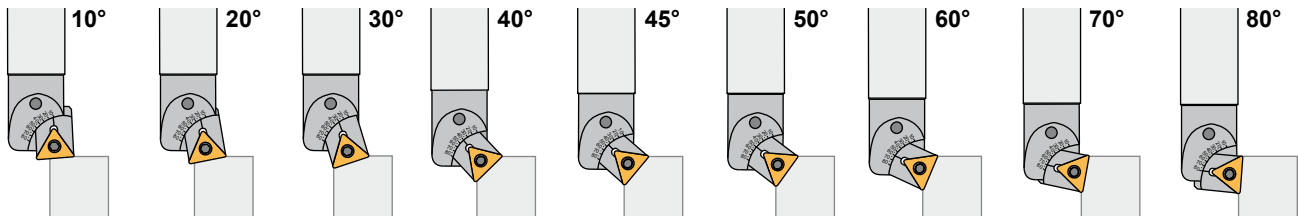



Characteristics:

Milling cutter with concave radius.
It works well on steels, alloyed steels,
stainless steels and refractories.

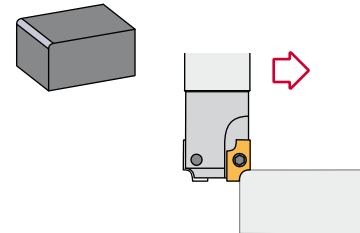
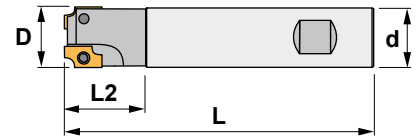

123507

Reference		d	D	L	L2	Insert size	
123507010001	2	1.000	1.000	6.00	1.500	ADMW1503R0.031/0.093	0.700
123507010003	2	1.000	1.000	6.00	1.500	ADMW1503R0.109/0.187	1.170

Reference			Nm
123507010001	1440	5515	3.0
123507010003	1440	5515	3.0

123507010001

ADMW1503R0.031 ADMW1503R0.046 ADMW1503R0.062 ADMW1503R0.078 ADMW1503R0.093



123507010003

ADMW1503R0.109 ADMW1503R0.125 ADMW1503R0.156 ADMW1503R0.171 ADMW1503R0.187



Parallelogram inserts / Positive

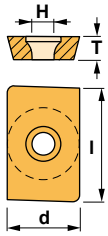

USE CLASSIFICATION

- Continuous
- ◐ Slight interruption
- ✚ Interruption

AVAILABILITY

- Standard item
- Check availability

P Steel	●	✚	●	✚	●	●	✚
M Stainless	●	●	●	✚	●	●	●
K Cast iron	●	✚	✚	●	●	●	●
N Non ferrous materials	✚	●	●	●	●	●	✚
S Heat-resistant alloys	●	●	●	●	●	●	●
H Hard materials	●	●	●	●	●	●	●



ADMW-R



Reference	l	T	d	r	KM15	PM25	PM40	TIN21	TIN25	TIN28	TL10	TL20	TL40	ZR10
ADMW1503R0.031	0.590	0.125	0.375	1/32					●					
ADMW1503R0.046	0.590	0.125	0.375	3/64					●					
ADMW1503R0.062	0.590	0.125	0.375	1/16					●					
ADMW1503R0.078	0.590	0.125	0.375	5/64					●					
ADMW1503R0.093	0.590	0.125	0.375	3/32					●					
ADMW1503R0.109	0.590	0.125	0.375	7/64					●					
ADMW1503R0.125	0.590	0.125	0.375	1/8					●					
ADMW1503R0.156	0.590	0.125	0.375	5/32					●					
ADMW1503R0.171	0.590	0.125	0.375	11/64					●					
ADMW1503R0.187	0.590	0.125	0.375	3/16					●					

Cutting data for slot side and face milling cutters

Determine spindle speed and feed:

To decide running speed of the tools and feed rate, please calculate spindle speed and feed rate according to the following formula and cutting data:

Feed nominal values

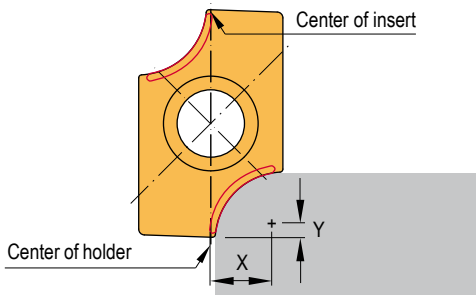

$d = 2 \times X \text{ in.}$

$S = \frac{Vc \times 1000}{d \times \pi} \text{ r.p.m}$

$F = S \times f \text{ in/min.}$

$TL = TL' - Y,$

$H = X$

Calculate spindle speed

d = diameter of the tool for calculation purpose.

X = tool radius offset.

Vc = Cutting Speed (sfm).

S = Spindle Speed (rpm).

F = in/min.

f = in/rev.

Calculate tool length offset on machining center

X = tool radius offset.

Y = distance to the center of radius.

TL' = tool length.

TL = tool length offset.

H = tool radius offset.

Material		Vc (sfm)	f (in/rev.)
Carbon steel	P	492~1049	0.001~0.003
Alloy steel		328~820	0.001~0.003
High alloy steel		262~492	0.001~0.003
Stainless steel	M	213~410	0.001~0.003
Cast iron	K	492~820	0.001~0.003
Aluminium, Al-alloy Si < 12%	N	492~1049	0.001~0.003
Al-alloy Si < 12%		328~984	0.001~0.003
Cu		656~820	0.001~0.003
Brass and Bronze		492~820	0.001~0.003





Characteristics:

Slot cutter with an angle of 92° that uses strong inserts allowing deep passes and high feed per teeth. Positive chip forming inserts are available to machine sticky materials.

Warning!! Not suitable for flat bottom applications.

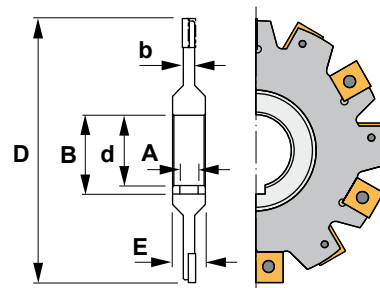
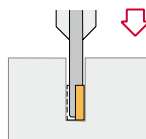
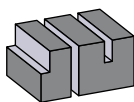

194290

Reference		D	b	d	A	E	B			Insert size	
194290040016	12	4.000	0.161	1.000	0.250	0.472	1.110	1735	5607	SNHX1102..	0.440
194290050016	14	5.000	0.161	1.250	0.315	0.472	1.375	1735	5607	SNHX1102..	0.770
194290040018	12	4.000	0.187	1.000	0.250	0.472	1.110	1835	5607	SNHX1103..	0.550
194290050018	14	5.000	0.187	1.250	0.315	0.472	1.375	1835	5607	SNHX1103..	0.880
194290060018	18	6.000	0.187	1.250	0.315	0.472	1.375	1835	5607	SNHX1103..	1.430
194290040025	10	4.000	0.250	1.250	0.315	0.472	1.375	1745	5615	SNHX1203..	0.660
194290050025	12	5.000	0.250	1.250	0.315	0.472	1.375	1745	5615	SNHX1203..	0.990
194290060025	16	6.000	0.250	1.500	0.378	0.472	1.689	1745	5615	SNHX1203..	1.650
194290080025	18	8.000	0.250	1.500	0.378	0.472	1.689	1745	5615	SNHX1203..	2.530
194290040031	10	4.000	0.312	1.250	0.315	0.472	1.375	1846	5615	SNHX1204..	0.770
194290050031	12	5.000	0.312	1.250	0.315	0.472	1.375	1846	5615	SNHX1204..	1.210
194290060031	16	6.000	0.312	1.500	0.378	0.472	1.689	1846	5615	SNHX1204..	2.090
194290080031	18	8.000	0.312	1.500	0.378	0.472	1.689	1846	5615	SNHX1204..	3.410
194290040037	10	4.000	0.375	1.250	0.315	0.472	1.375	1845	5615	SNHX1205..	0.880
194290050037	12	5.000	0.375	1.250	0.315	0.472	1.375	1845	5615	SNHX1205..	1.540
194290060037	16	6.000	0.375	1.500	0.378	0.472	1.689	1845	5615	SNHX1205..	2.530
194290080037	18	8.000	0.375	1.500	0.378	0.472	1.689	1845	5615	SNHX1205..	4.180
194290040050	10	4.000	0.500	1.250	0.315	0.630	1.375	1847	5615	SNHX1207..	1.100
194290050050	12	5.000	0.500	1.250	0.315	0.630	1.375	1847	5615	SNHX1207..	1.870
194290060050	16	6.000	0.500	1.500	0.378	0.630	1.689	1847	5615	SNHX1207..	3.080
194290080050	18	8.000	0.500	1.500	0.378	0.630	1.689	1847	5615	SNHX1207..	5.170

Square inserts / Negative

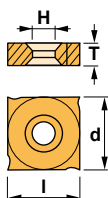

SNHX

Reference	l	T	d	H	KM15	PM25	PM40	TIN21	TIN25	TIN28	TL10	TL20	TL40	ZR10
SNHX1102XX	0.433	0.094	0.433	0.165					●				●	
SNHX1103XX	0.433	0.106	0.433	0.165					●				●	
SNHX1203XX	0.500	0.125	0.500	0.203					●				●	
SNHX12045XX	0.500	0.177	0.500	0.203					●				●	
SNHX1205XX	0.500	0.213	0.500	0.203					●				●	
SNHX1207XX	0.500	0.276	0.500	0.203					●				●	

Cutting data for slot side and face milling cutters

Cutting speed nominal values - hm 0.002-0.005

Material	P	HB	TIN25	TL40
			Cutting speed m/min.	
Unalloyed steel		110-310	140-240	130-250
Low alloyed steel		125-450	130-210	85-180
High alloyed steel		150-500	120-80	60-120
Stainless		150-270		
Steel castings		150-250	130-210	55-115
Material	M	HB	TIN25	TL40
			Cutting speed m/min.	
Austenitic, Stainless steel			40-90	
Titanium				20-80
Material	K	HB	TIN25	
			Cutting speed m/min.	
Malleable cast iron		110-230	55-100	
Grey cast iron		180-260	60-120	
Nodular cast iron-S. graphite		160-250	40-80	
Alumimium alloys		30-100		
Bronze and brass alloys		60-150		

Feed nominal values

The chip average thickness (h_m) must be 0.004".

This corresponds to a feed per tooth of 0.012" in most of the operations made by a side and face milling cutter.

If the radial cutting depth (a_e) is too small compared with the milling cutter diameter, use the following formula:

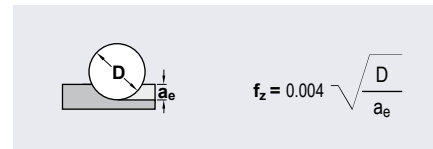

$$f_z = 0.004 \sqrt{\frac{D}{a_e}}$$

NOTE:

In order to calculate the table feeds, use the half of the inserts in a three cut milling cutter and a face milling cutter in order to get the effective number of teeth.

$$\text{Table feed} = \text{rpm} \times \text{number of effective teeth} \times f_z$$

Machining example

Working piece

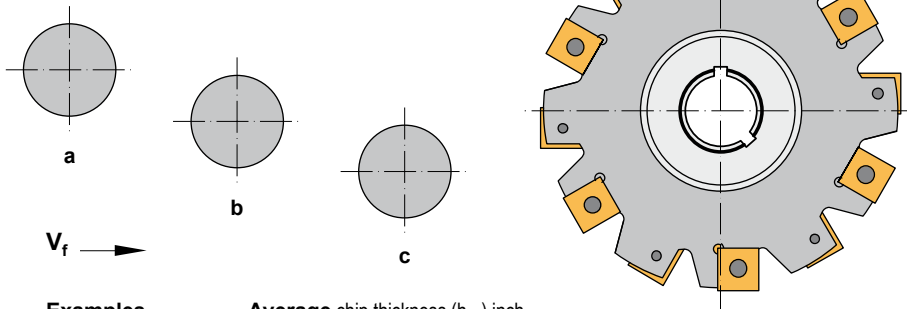

Examples	Average chip thickness (h_m) inch
a	0.003 - 0.0035
b	0.003
c	0.0025 - 0.003

Example a: $f_z \sim h_m$ Example c: $f_z = h_m \sqrt{\frac{D}{a_e}}$

Example b: f_z must be calculated between examples "a" and "b".

- f_z = Feed per tooth
- D = Milling cutter diameter
- a_e = Radial cutting depth
- h_m = Average chip thickness

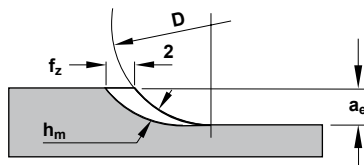

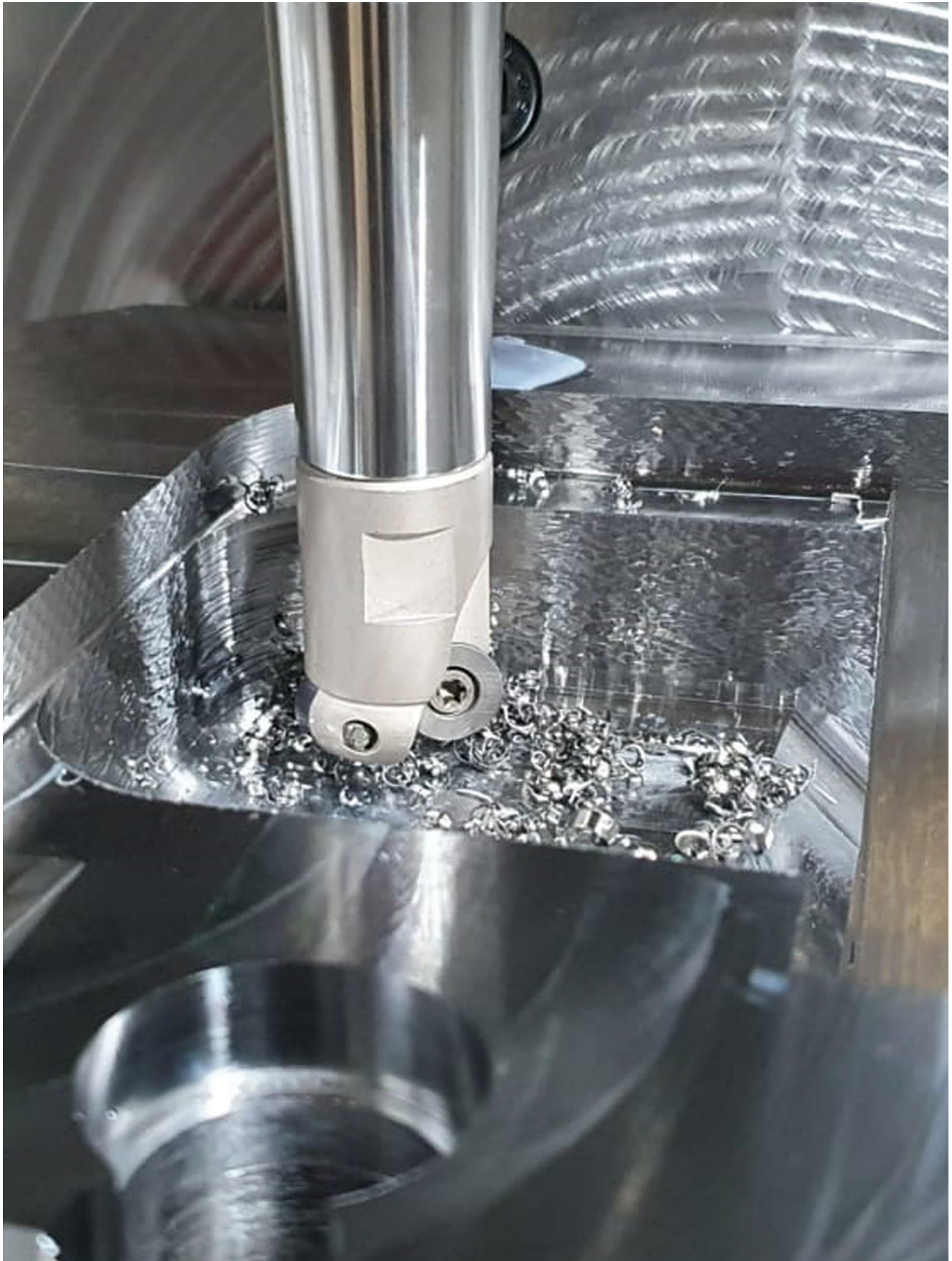

High feed

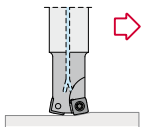
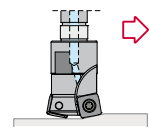
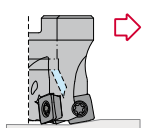
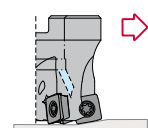
<p>16₄903 High feed</p>  <p>SP..0735.. SP..0945.. SP..1155..</p> <p>Page G52</p>	<p>16₄906 High feed</p>  <p>SP..0735.. SP..0945.. SP..1155..</p> <p>Page G52</p>	<p>163993 High feed</p>  <p>SP..0945..</p> <p>Page G54</p>	<p>164993 High feed</p>  <p>SP..1155..</p> <p>Page G54</p>	
---	---	--	---	--

Round inserts

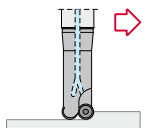
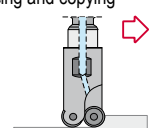
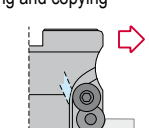
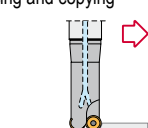
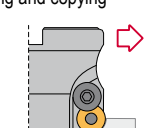
<p>55_5 Facing and copying</p>  <p>RD..1003.. RD..1604..</p> <p>Page G58</p>	<p>55_506 Facing and copying</p>  <p>RD..1003.. RD..1604..</p> <p>Page G58</p>	<p>55₅590 Facing and copying</p>  <p>RD..1204.. RD..1604..</p> <p>Page G60</p>	<p>5549⁰¹₀₂ Facing and copying</p>  <p>RPM..1204..</p> <p>Page G62</p>	<p>554990 Facing and copying</p>  <p>RPM..1204..</p> <p>Page G64</p>
--	--	---	---	--

Finishing ball nose

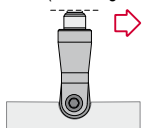
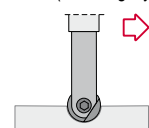
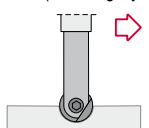
<p>87_06 Copy applications (Finishing Modular)</p>  <p>HIB..0375 HIB..1250</p> <p>Page G66</p>	<p>87_00 Copy applications (Finishing Cylindric)</p>  <p>HIB..0375 HIB..1250</p> <p>Page G67</p>	<p>87_01 Copy applications (Finishing Cylindric)</p>  <p>HIB..0375 HIB..1250</p> <p>Page G67</p>		
--	--	--	--	--

Aluminium die cutting

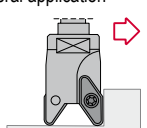
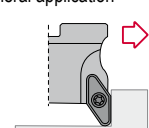
<p>034406 General application</p>  <p>VCGT33.. VCGT2205..</p> <p>Page G70</p>	<p>034490 General application</p>  <p>VCGT2205..</p> <p>Page G70</p>			
---	--	--	--	--





Characteristics:
 High feed square insert cutter for peripheral milling, ramp milling and drilling, pocket milling and copy milling.
 It can be used in only one pass (roughing and finishing) and it is recommended for machining centers.

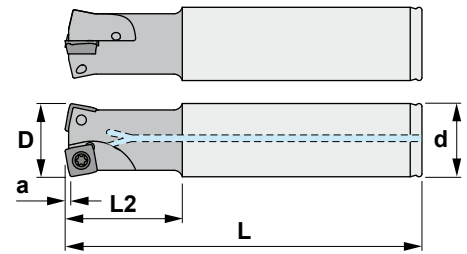
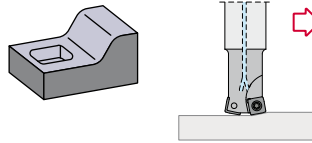

16²₄903

Reference		D	L	L2	d	a	Insert size			Nm	
1629030075	3	0.750	6.00	1.181	0.750	0.035	SP..0735..	1430-IP	5510-IP	2.5	0.660
1629030100	4	1.000	8.00	1.378	1.000	0.035	SP..0735..	1430-IP	5510-IP	2.5	0.970
1639030100	2	1.000	6.00	1.378	1.000	0.055	SP..0945..	1440-IP	5515-IP	2.5	0.970
1639030125	4	1.250	8.00	1.693	1.250	0.055	SP..0945..	1440-IP	5515-IP	3.5	1.720
1649030125	3	1.250	8.00	1.693	1.250	0.070	SP..1155..	1240-IP	5515-IP	3.5	1.675



Characteristics:
 High feed square insert cutter for peripheral milling, ramp milling and drilling, pocket milling and copy milling.
 It can be used in only one pass (roughing and finishing) and it is recommended for machining centers.

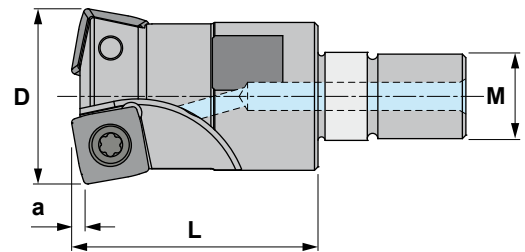
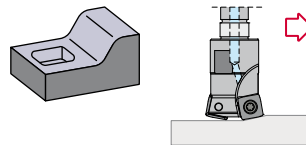

16²₄906

Reference		D	L	M	a	Insert size	
1629060075	3	0.750	1.181	M10	0.035	SP..0735..	0.132
1629060100	4	1.000	1.378	M12	0.035	SP..0735..	0.209
1629060125	5	1.250	1.693	M16	0.035	SP..0735..	0.506
1639060100	2	1.000	1.378	M12	0.055	SP..0945..	0.175
1649060125	3	1.250	1.693	M16	0.070	SP..1155..	0.375

WARNING!! Modular Extensions (Pages F07 to F13).

Reference			Nm
1629060075	1430-IP	5510-IP	2.5
1629060100	1430-IP	5510-IP	2.5
1629060125	1430-IP	5510-IP	2.5
1639060100	1440-IP	5515-IP	3.5
1649060125	1240-IP	5515-IP	3.5

High feed inserts / Positive

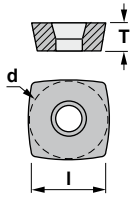

USE CLASSIFICATION

- Continuous
- ◐ Slight interruption
- ⊕ Interruption

AVAILABILITY

- Standard item
- Check availability

P Steel	●	⊕	●	⊕	⊕	●	●	⊕
M Stainless	●	●	●	⊕	⊕	●	●	●
K Cast iron	⊕	⊕	⊕	⊕	⊕	⊕	⊕	⊕
N Non ferrous materials	⊕	●	●	●	●	●	●	⊕
S Heat-resistant alloys	●	●	●	●	●	●	●	●
H Hard materials	●	●	●	●	●	●	●	●



SPMT



Reference	I	T	d
SPMT073505	0.275	0.137	0.275
SPMT094506	0.380	0.173	0.380
SPMT115506	0.457	0.212	0.457

KM15	PM25	PM40	TIN21	TIN25	TIN28	TL10	ML30	TL40	ZR10
●	●	●	●	●	●	●	●	●	●



SPMX



Reference	I	T	d
SPMX073505	0.275	0.137	0.275
SPMX094506	0.380	0.173	0.380
SPMX115506	0.457	0.212	0.457

KM15	PM25	PM40	TIN21	TIN25	TIN28	TL10	TL20	TL40	ZR10
●	●	●	●	●	●	●	●	●	●

Note:

For more information see pages G56 and G57.

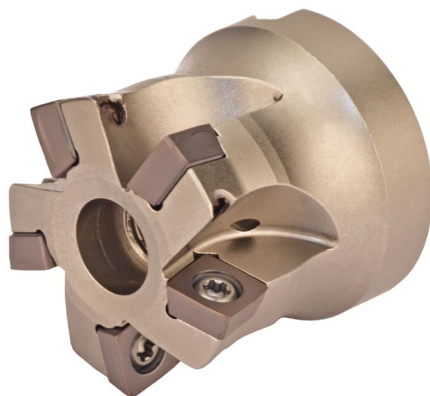

**Characteristics:**

High feed square insert cutter for peripheral milling, ramp milling and drilling, pocket milling and copy milling.

It can be used in only one pass (roughing and finishing) and it is recommended for machining centers.

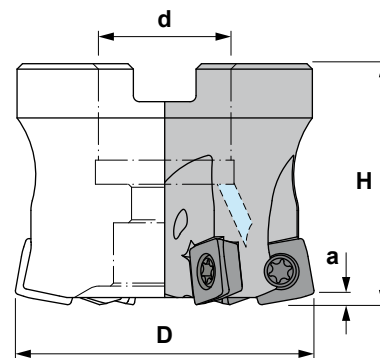
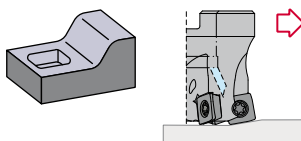
**163993**

Reference		D	H	d	a	Insert size	
1639930150	5	1.500	1.750	0.500	0.055	SP..0945..	0.440
1639930200	6	2.000	2.000	0.750	0.055	SP..0945..	0.990

Reference				Nm
1639930150	1440-IP	5515-IP	UNF.14	3.5
1639930200	1440-IP	5515-IP	UNF.38	3.5

**Characteristics:**

High feed square insert cutter for peripheral milling, ramp milling and drilling, pocket milling and copy milling.

It can be used in only one pass (roughing and finishing) and it is recommended for machining centers.

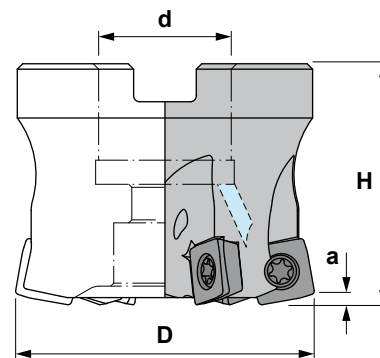
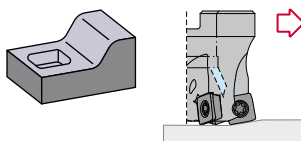
**164993**

Reference		D	H	d	a	Insert size	
1649930200	5	2.000	2.000	0.750	0.070	SP..1155..	0.640
1649930250	6	2.500	2.000	1.000	0.070	SP..1155..	1.590
1649930300	8	3.000	2.000	1.000	0.070	SP..1155..	2.000

Reference				Nm
1649930200	1240-IP	5515-IP	UNF.38	3.5
1649930250	1240-IP	5515-IP	UNF.12	3.5
1649930300	1240-IP	5515-IP	UNF.12	3.5

High feed inserts / Positive

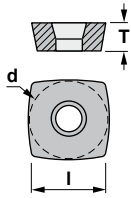

USE CLASSIFICATION

- Continuous
- ◐ Slight interruption
- ✚ Interruption

AVAILABILITY

- Standard item
- Check availability

P Steel	●	✚	●	✚	●	●	✚
M Stainless	●	●	●	✚	●	●	●
K Cast iron	●	✚	✚	●	●	●	●
N Non ferrous materials	✚	●	●	●	●	●	✚
S Heat-resistant alloys	●	●	●	●	●	●	●
H Hard materials	●	●	●	●	●	●	●



SPMT



Reference	I	T	d	KM15	PM25	PM40	TIN21	TIN25	TIN28	TL10	ML30	TL40	ZR10
SPMT094506	0.380	0.173	0.380								●		
SPMT115506	0.457	0.212	0.457								●		



SPMX



Reference	I	T	d	KM15	PM25	PM40	TIN21	TIN25	TIN28	TL10	TL20	TL40	ZR10
SPMX094506	0.380	0.173	0.380								●		
SPMX115506	0.457	0.212	0.457								●		

Note:

For more information see pages G56 and G57.



Recommended cutting conditions

Material	P	Hardness	Insert	Grade	Standard milling				High feed milling			
					Vc	fz	ap	ae	Vc	fz	ap	ae
Mild steel	<180HB	SPMT/X073505	TL20	170 (120-220)	1.0	0.3/0.8	100%/DC	200	1.0	0.4	100%/DC	
					1.2	0.5/1.0	100%/DC		1.4	0.5	100%/DC	
					1.5	0.8/1.5	100%/DC		1.4	0.8	100%/DC	
Carbon steel, alloyed steel	180-280HB	SPMT/X073505	TL20	150 (100-200)	0.9	0.3/0.5	100%/DC	200			100%/DC	
					1.0	0.5/0.7	100%/DC		1.2	0.5	100%/DC	
					1.2	0.6/1.5	100%/DC		1.2	0.8	100%/DC	
Carbon steel, alloyed steel	280-350HB	SPMT/X073505	TL20	120 (80-150)	0.9	0.3/0.5	100%/DC	180	0.9	0.3	100%/DC	
					1.0	0.5/0.7	100%/DC		1.2	0.4	100%/DC	
					1.2	0.5/1.0	100%/DC		1.2	0.6	100%/DC	
Alloyed tool steel	<350HB	SPMT/X073505	TL20	120 (80-140)	0.75	0.3/0.5	100%/DC	180	0.75	0.3	100%/DC	
					1.0	0.5/0.7	100%/DC		0.8	0.4	100%/DC	
					1.0	0.5/1.0	100%/DC		0.8	0.6	100%/DC	
Prehardened steel	35-45HRC	SPMT/X073505	TL20	100 (70-130)	0.75	0.25/0.4	100%/DC	150	0.75	0.3	100%/DC	
					0.8	0.4/0.6	100%/DC		0.8	0.4	100%/DC	
					0.8	0.4/0.8	100%/DC		0.8	0.5	100%/DC	

Material	M	Hardness	Insert	Grade	Standard milling				High feed milling			
					Vc	fz	ap	ae	Vc	fz	ap	ae
Stainless steel	<200HB	SPMT073505	ML30	100 (60-120)	0.3	0.4/0.8	100%/DC	-	-	-	-	
					0.4	0.5/1.0	100%/DC		-	-	-	
					0.4	0.6/1.5	100%/DC		-	-	-	
PH, Duplex	<200HB	SPMT073505	ML30	70 (50-90)	0.3	0.25/0.4	100%/DC	-	-	-	-	
					0.4	0.3/0.5	100%/DC		-	-	-	
					0.4	0.4/0.8	100%/DC		-	-	-	

Material	K	Hardness	Insert	Grade	Standard milling				High feed milling			
					Vc	fz	ap	ae	Vc	fz	ap	ae
Grey cast iron	<200HB	SPMX073505	TL20	150 (100-200)	1.0	0.3/0.6	100%/DC	-				
					1.2	0.5/0.8	100%/DC		-	-	-	
					1.2	0.6/1.5	100%/DC		-	-	-	
Ductile cast iron	<450MPa	SPMX073505	TL20	120 (80-160)	0.8	0.25/0.5	100%/DC	-				
					1.0	0.4/0.6	100%/DC		-	-	-	
					1.0	0.5/0.8	100%/DC		-	-	-	

Material	H	Hardness	Insert	Grade	Standard milling				High feed milling			
					Vc	fz	ap	ae	Vc	fz	ap	ae
Hardened steel	40-55HRC	SPMX073505	TL20	70 (50-90)	0.5	0.25/0.4	100%/DC	120	0.5	0.25	100%/DC	
					0.6	0.3/0.5	100%/DC		0.6	0.3	100%/DC	
					0.6	0.3/0.6	100%/DC		0.6	0.4	100%/DC	

Configuration note

When using the milling cutter 1629, 1639 or 1649 it must be configured as a milling cutter with radius RE. The approximate uncut portions cut of the configurations are the following:

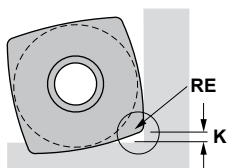

Insert size	RE	K mm
SPMX073505	1.7	0.82
SPMX094506	2.3	1.6
SPMX115506	2.7	2.1

Processing by direct milling is also possible

Since the cutting flute does not extend to the center, there are limitations on the ramp angle and hole diameter, but as shown below, processing by direct milling without a pilot hole is possible for ramping and helical milling.

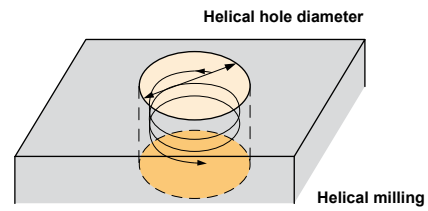
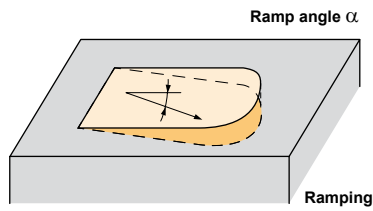

Insert size	SPMX0735..		
Tool diameter	Ø0.750	Ø1.000	Ø1.250
Maximum ramp angle α	2°	2°	1°
Hole diameter	Ø1.07-1.42	Ø1.57-1.92	Ø2.07-2.42

Insert size	SPMX0945..			
Tool diameter	Ø1.000	Ø1.250	Ø1.500	Ø2.000
Maximum ramp angle α	2°	2°	1°	1°
Hole diameter	Ø1.45-1.92	Ø1.95-2.42	Ø2.45-2.92	Ø3.45-3.92

Insert size	SPMX1155..			
Tool diameter	Ø1.250	Ø2.000	Ø2.500	Ø3.000
Maximum ramp angle α	2°	1°	0.5°	0.5°
Hole diameter	Ø1.83-2.42	Ø3.33-3.92	Ø4.33-4.92	Ø5.33-5.92

Note

- The ramp angle α should be set within the ranges listed above. Use at ramp angles of 1° or less recommended.
- For hole diameters outside the ranges listed above, a pilot hole should be drilled before milling.





Characteristics:
 Round insert end mill for slot milling, peripheral milling, ramp milling and drilling, pocket milling and copy milling.
 It can be used in only one pass (roughing and finishing) and it is recommended for conventional milling machines and machining centers.

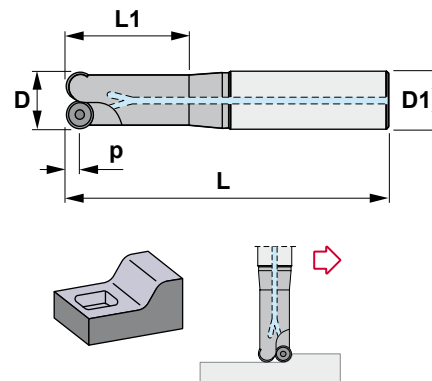

55_5

Reference		D	L	D1	L1	p	Insert size			Nm	
5535000075	2	0.750	4	0.750	1.637	0.197	RD..1003M0	1435	5515	3.0	0.484
5535010075	2	0.750	6	0.750	3.637	0.197	RD..1003M0	1435	5515	3.0	0.748
5545000100	2	1.000	5	1.000	1.850	0.236	RD..1204M0	1435	5515	3.0	1.012
5545010100	2	1.000	7	1.000	3.850	0.236	RD..1204M0	1435	5515	3.0	1.474
5545000125	3	1.250	5	1.250	1.850	0.236	RD..1204M0	1435	5515	3.0	1.628
5545010125	3	1.250	8	1.250	4.850	0.236	RD..1204M0	1435	5515	3.0	2.376
5555000125	2	1.250	5	1.250	1.850	0.315	RD..1604M0	1445	5515	3.0	2.376
5555010125	2	1.250	8	1.250	4.850	0.315	RD..1604M0	1445	5515	3.0	2.376



Characteristics:
 Round insert end mill for slot milling, peripheral milling, ramp milling and drilling, pocket milling and copy milling.
 It can be used in only one pass (roughing and finishing) and it is recommended for conventional milling machines and machining centers.

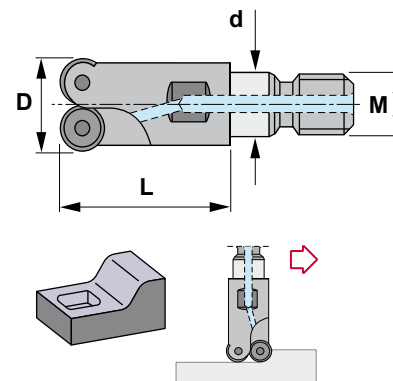

55_506

Reference		D	L	M	d	Insert size	
5535060075	2	0.750	1.181	M10	0.413	RD..1003..	0.132
5545060100	2	1.000	1.378	M12	0.492	RD..1204..	0.209
5545060125	3	1.250	1.693	M16	0.669	RD..1204..	0.506
5555060125	2	1.250	1.693	M16	0.669	RD..1604..	0.506

WARNING!! Modular Extensions (Pages F07 to F13).

Reference			Nm
5535060075	1435	5515	3.0
5545060100	1435	5515	3.0
5545060125	1435	5515	3.0
5555060125	1445	5515	3.0

Round inserts / Positive

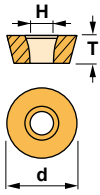

- USE CLASSIFICATION**
 - Continuous
 - ◐ Slight interruption
 - ⊕ Interruption
- AVAILABILITY**
 - Standard item
 - Check availability

P Steel	●	⊕	⊕	⊕	⊕	●	●	⊕
M Stainless	●	●	●	●	●	●	●	●
K Cast iron	●	⊕	⊕	⊕	⊕	●	●	●
N Non ferrous materials	⊕	●	●	●	●	●	●	⊕
S Heat-resistant alloys	●	●	●	●	●	●	●	●
H Hard materials	●	●	●	●	●	●	●	●



RDHW



Reference	T	d	H
RDHW1003M0	0.125	0.394	0.159
RDHW12T3M0	0.156	0.472	0.165
RDHW1604M0	0.187	0.630	0.201

KM15	PM25	PM40	TIN21	TIN25	TIN28	TL10	TL20	TL40	ZR10
●	●	●	●	●	●	●	●	●	●



RDMT



Reference	T	d	H
RDMT1003M0	0.125	0.394	0.159
RDMT12T3M0	0.156	0.472	0.165
RDMT1604M0	0.187	0.630	0.200

KM15	PM25	PM40	TIN21	TIN25	TIN28	TL10	TL20	TL40	ZR10
●	●	●	●	●	●	●	●	●	●



RDMW



Reference	T	d	H
RDMW1003M0	0.125	0.394	0.165
RDMW12T3M0	0.156	0.472	0.165
RDMW1204M0	0.187	0.472	0.165
RDMW1604M0	0.187	0.630	0.200

KM15	PM25	PM40	TIN21	TIN25	TIN28	TL10	TL20	TL40	ZR10
●	●	●	●	●	●	●	●	●	●

Recommended cutting conditions (End Mill & Modular Head Style)

Material	Insert Grade	TOOL DIAMETER									
		0.750"		1.000"		1.250"		1.500"		2.000"	
		MAX D.O.C.									
		0.08"		0.10"		0.12"		0.14"		0.16"	
		N r.p.m	F inch/min	N r.p.m	F inch/min	N r.p.m	F inch/min	N r.p.m	F inch/min	N r.p.m	F inch/min
Low Carbon steels (125-180 HB)	TL20 - TL40	4.000	110	3.100	85	2.450	70	2.000	55	1.600	45
Carbon steels (170-220 HB)	TL20 - TL40	3.500	95	2.700	75	2.200	60	1.750	50	1.400	40
Alloyed steels (200-260 HB)	TL20 - TL40	2.500	70	2.200	55	1.700	45	1.400	35	1.100	30
Tool & Die steels (280-370 HB)	TL20 - TL40	2.200	60	1.900	50	1.500	40	1.200	30	950	25
Stainless steels (150-270 HB)	TL20 - TL40	2.800	70	2.200	55	1.700	45	1.350	35	1.100	30
Gray Cast Iron (200-250 HB)	TL20 - TL40	3.000	100	2.400	80	1.900	60	1.500	50	1.200	40
Nodular Cast Iron (180-250 HB)	TL20 - TL40	2.400	80	1.900	65	1.500	50	1.200	40	950	30

Note: Above data is relevant to tools with ratio (Reach/Dia.) of 4xs and below. For tools above 4xs, see Table 3.

Additional cutting data for longer tools

Reach/Dia.	~4.0	4.0~4.5	4.5~5.3	5.3~5.7	5.7~6.2	6.3~
rpm %	100	90	80	80	75	70
Feed %	100	90	90	80	75	70

Note: The above percentages should be applied for longer tools.

Reduced cutting data for cutting pattern

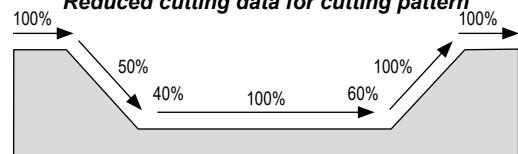

Note: Feed should be reduced when cutting the above pattern.



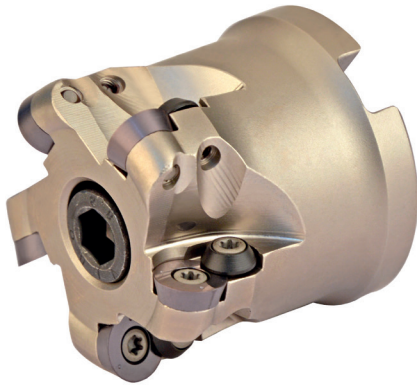

Characteristics:
 Round insert cutter for slot milling, peripheral milling, ramp milling and drilling, pocket milling and copy milling.
 It can be used in only one pass (roughing and finishing) and it is recommended for conventional milling machines and machining centers.

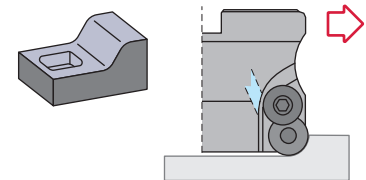
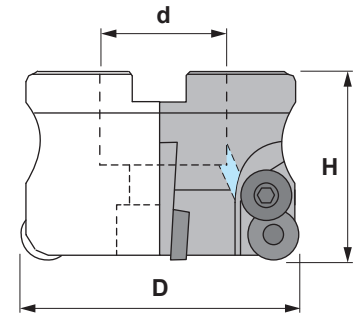

55⁴₅590

Reference		D	H	d	Insert size	
5545900200	5	2.000	2.000	0.750	RD..12T3..	0.990
5545900250	6	2.500	2.000	1.000	RD..12T3..	1.694
5545900300	7	3.000	2.000	1.000	RD..12T3..	2.640
5555900200	4	2.000	2.000	0.750	RD..1604..	0.770
5555900250	5	2.500	2.000	1.000	RD..1604..	1.540
5555900300	6	3.000	2.000	1.000	RD..1604..	2.310
5555900400	7	4.000	2.000	1.250	RD..1604..	3.960

Reference						Nm
5545900200	1235	2009	UNF.38	5515	-	3.0
5545900250	1235	2009	UNF.12	5515	-	3.0
5545900300	1235	2009	UNF.12	5515	-	3.0
5555900200	1245	2010	UNF.38	5515	-	3.0
5555900250	1245	2010	UNF.12	5515	-	3.0
5555900300	1245	2010	UNF.12	5515	-	3.0
5555900400	1245	2010	-	-	5615	3.0

RD.. Round positive inserts with 15° clearance. G08-09

Reference	T	d
RD..12T3M0	0.156	0.472
RD..1604M0	0.187	0.630

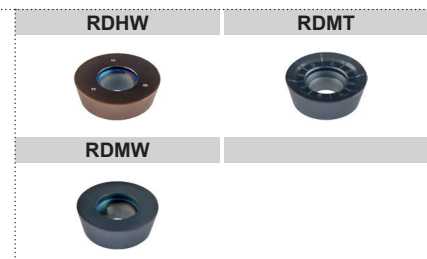
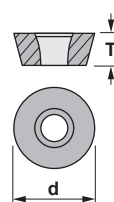

Round inserts / Positive

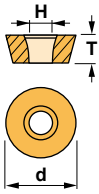

USE CLASSIFICATION

- Continuous
- Slight interruption
- ⊕ Interruption

AVAILABILITY

- Standard item
- Check availability

P Steel	●	⊕	●	⊕	●	●	⊕
M Stainless	●	●	●	⊕	●	●	●
K Cast iron	●	⊕	⊕	⊕	●	●	●
N Non ferrous materials	⊕	●	●	●	●	●	⊕
S Heat-resistant alloys	●	●	●	●	●	●	●
H Hard materials	●	●	●	●	●	●	●



RDHW



Reference	T	d	H
RDHW12T3M0	0.156	0.472	0.165
RDHW1604M0	0.187	0.630	0.201

KM15	PM25	PM40	TIN21	TIN25	TIN28	TL10	TL20	TL40	ZR10
------	------	------	-------	-------	-------	------	------	------	------



RDMT



Reference	T	d	H
RDMT12T3M0	0.156	0.472	0.165
RDMT1604M0	0.187	0.630	0.200

KM15	PM25	PM40	TIN21	TIN25	TIN28	TL10	TL20	TL40	ZR10
------	------	------	-------	-------	-------	------	------	------	------



RDMW



Reference	T	d	H
RDMW12T3M0	0.156	0.472	0.165
RDMW1204M0	0.187	0.472	0.165
RDMW1604M0	0.187	0.630	0.200

KM15	PM25	PM40	TIN21	TIN25	TIN28	TL10	TL20	TL40	ZR10
------	------	------	-------	-------	-------	------	------	------	------

Recommended cutting conditions (Face Mill Style)

Material	Insert Grade	TOOL DIAMETER (teeth)													
		2.00" (3/4/5 teeth)		2.25" (4 teeth)		2.50" (5/6 teeth)		3.00" (5/6/7 teeth)		4.00" (6/7 teeth)		5.00" (7/8 teeth)		6.00" (8/9 teeth)	
		MAX D.O.C.													
		0.160"		0.200"		0.200" / 0.160"		.240" / .200 / .160"		0.240" / 0.200"		0.240" / 0.200"		0.240" / 0.200"	
N r.p.m		F inch/min		N r.p.m		F inch/min		N r.p.m		F inch/min		N r.p.m		F inch/min	
Low Carbon steels (125-180 HB)	TL20 - TL40	1.400	50/65/85	1.280	60	1.090	63/78	900	57/64/72	720	70/77	570	48/53	450	57/63
Carbon steels (170-220 HB)	TL20 - TL40	1.250	45/60/75	1.150	55	950	55/67	750	48/53/80	610	60/67	500	43/47	400	50/55
Alloyed steels (200-260 HB)	TL20 - TL40	900	35/45/55	820	40	670	40/47	500	30/35/42	400	43/47	350	30/33	280	35/40
Tool & Die steels (30-40 HRC)	TL20 - TL40	750	27/35/45	680	32	580	35/42	450	27/32/37	350	35/41	300	25/28	200	30/35
Stainless steels (150-270 HB)	TL20 - TL40	1.050	40/50/82	950	45	820	47/57	550	40/48/53	520	51/57	400	32/35	320	43/47
Gray Cast Iron (200-250 HB)	TL20 - TL40	1.080	50/68/85	980	62	850	50/80	700	55/66/77	560	72/80	450	50/55	360	45/50
Nodular Cast Iron (180-250 HB)	TL20 - TL40	900	43/57/70	820	52	700	42/67	600	48/57/66	460	60/67	370	40/45	300	40/45

Reduced cutting data for cutting pattern

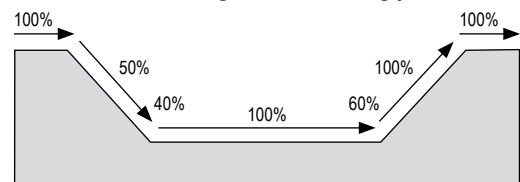

Note: Feed rate should be reduced when cutting the above pattern.







Characteristics:

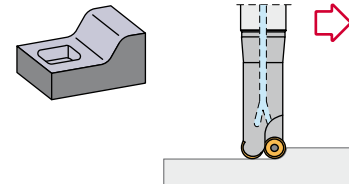
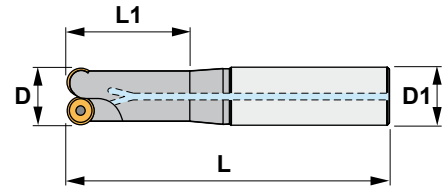

Round insert end mill for slot milling, peripheral milling, ramp milling and drilling, pocket milling and copy milling.

It can be used in only one pass (roughing and finishing) and it is recommended for conventional milling machines and machining centers.



5549⁰¹/₀₂

Reference		D	L	D1	L1	Insert size	
5549010100	2	1.000	6.00	1.000	2.00	RPM..1204M0	1.474
5549020100	2	1.000	8.00	1.000	3.00	RPM..1204M0	1.474
5549010125	3	1.250	6.00	1.250	2.00	RPM..1204M0	2.376
5549020125	3	1.250	8.00	1.250	3.00	RPM..1204M0	2.376

Reference			Nm
5549010100	1435	5515	3.0
5549020100	1435	5515	3.0
5549010125	1435	5515	3.0
5549020125	1435	5515	3.0



Round inserts / Positive

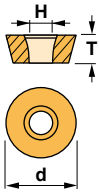

- USE CLASSIFICATION**
 - Continuous
 - Slight interruption
 - ⊕ Interruption
- AVAILABILITY**
 - Standard item
 - Check availability

P Steel	●	⊕	●	⊕	●	⊕	●	⊕	●	⊕	●	⊕
M Stainless	●	●	●	●	●	●	●	●	●	●	●	●
K Cast iron	●	⊕	●	⊕	●	⊕	●	⊕	●	⊕	●	⊕
N Non ferrous materials	●	●	●	●	●	●	●	●	●	●	●	●
S Heat-resistant alloys	●	●	●	●	●	●	●	●	●	●	●	●
H Hard materials	●	●	●	●	●	●	●	●	●	●	●	●



RPMT



Reference	T	d	H
RPMT120400-39	0.187	0.500	0.203
RPMT1204M0	0.187	0.472	0.203

KM15	PM25	PM40	TIN21	TIN25	TIN28	TL10	TL20	TL40	ZR10
	●			●					
			●	●					



RPMW



Reference	T	d	H
RPMW1204M0	0.187	0.472	0.165
RPMW1204M0T	0.187	0.472	0.165

KM15	PM25	PM40	TIN21	TIN25	TIN28	TL10	TL20	TL40	ZR10
				●	●				
			●	●					

Recommended cutting conditions (End Mill & Modular Head Style)

Material	Insert Grade	TOOL DIAMETER									
		0.750"		1.000"		1.250"		1.500"		2.000"	
		MAX D.O.C.									
		0.08"		0.10"		0.12"		0.14"		0.16"	
		N r.p.m	F inch/min	N r.p.m	F inch/min	N r.p.m	F inch/min	N r.p.m	F inch/min	N r.p.m	F inch/min
Low Carbon steels (125-180 HB)	TL20 - TL40	4.000	110	3.100	85	2.450	70	2.000	55	1.600	45
Carbon steels (170-220 HB)	TL20 - TL40	3.500	95	2.700	75	2.200	60	1.750	50	1.400	40
Alloyed steels (200-260 HB)	TL20 - TL40	2.500	70	2.200	55	1.700	45	1.400	35	1.100	30
Tool & Die steels (280-370 HB)	TL20 - TL40	2.200	60	1.900	50	1.500	40	1.200	30	950	25
Stainless steels (150-270 HB)	TL20 - TL40	2.800	70	2.200	55	1.700	45	1.350	35	1.100	30
Gray Cast Iron (200-250 HB)	TL20 - TL40	3.000	100	2.400	80	1.900	60	1.500	50	1.200	40
Nodular Cast Iron (180-250 HB)	TL20 - TL40	2.400	80	1.900	65	1.500	50	1.200	40	950	30

Note: Above data is relevant to tools with ratio (Reach/Dia.) of 4xs and below. For tools above 4xs, see Table 3.

Additional cutting data for longer tools

Reach/Dia.	~4.0	4.0~4.5	4.5~5.3	5.3~5.7	5.7~6.2	6.3~
rpm %	100	90	80	80	75	70
Feed %	100	90	90	80	75	70

Note: The above percentages should be applied for longer tools.

Reduced cutting data for cutting pattern

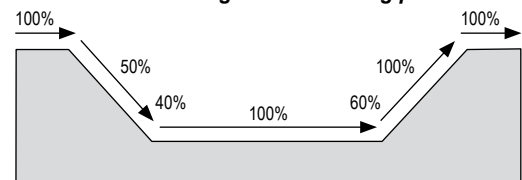

Note: Feed should be reduced when cutting the above pattern.



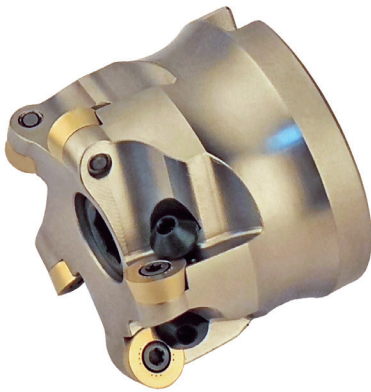

Characteristics:

Round insert cutter for slot milling, peripheral milling, ramp milling and drilling, pocket milling and copy milling.

It can be used in only one pass (roughing and finishing) and it is recommended for conventional milling machines and machining centers.

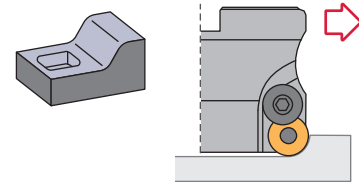
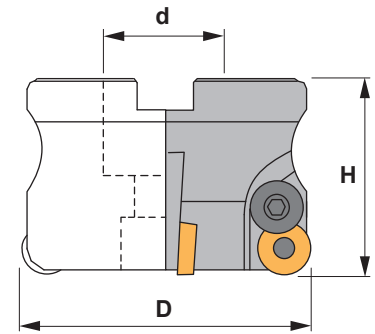

554990

Reference		D	H	d	Insert size	
5549900150	3	1.500	1.750	0.500	RPM..1204M0	0.440
5549900200	5	2.000	2.000	0.750	RPM..1204M0	0.660
5549900250	5	2.500	2.000	1.000	RPM..1204M0	1.430
5549900300	6	3.000	2.000	1.000	RPM..1204M0	2.530
5549900400	7	4.000	2.000	1.250	RPM..1204M0	3.850

Reference								Nm
5549900150	1235	2009	5003	1240	5515	-	UNF.14	3.0
5549900200	1235	2009	5003	1240	5515	-	UNF.38	3.0
5549900250	1235	2009	5003	1240	5515	-	UNF.12	3.0
5549900300	1235	2009	5003	1240	5515	-	UNF.12	3.0
5549900400	1235	2009	5003	1240	-	5615	-	3.0



Round inserts / Positive

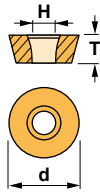

USE CLASSIFICATION

- Continuous
- Slight interruption
- ⊕ Interruption

AVAILABILITY

- Standard item
- Check availability

P Steel	●	⊕	●	⊕	⊕	●	●	⊕
M Stainless	●	●	●	⊕	⊕	●	●	●
K Cast iron	●	⊕	⊕	⊕	⊕	●	●	●
N Non ferrous materials	⊕	●	●	●	●	●	●	⊕
S Heat-resistant alloys	●	●	●	●	●	●	●	●
H Hard materials	●	●	●	●	●	●	●	●

RPMT



Reference	T	d	H	KM15	PM25	PM40	TIN21	TIN25	TIN28	TL10	TL20	TL40	ZR10
RPMT120400-39	0.187	0.500	0.203	●	●	●	●	●	●	●	●	●	●
RPMT1204M0	0.187	0.472	0.203	●	●	●	●	●	●	●	●	●	●

RPMW



Reference	T	d	H	KM15	PM25	PM40	TIN21	TIN25	TIN28	TL10	TL20	TL40	ZR10
RPMW1204M0	0.187	0.472	0.165	●	●	●	●	●	●	●	●	●	●
RPMW1204M0T	0.187	0.472	0.165	●	●	●	●	●	●	●	●	●	●

Recommended cutting conditions (Face Mill Style)

Material	Insert Grade	TOOL DIAMETER (teeth)													
		2.00" (3/4/5 teeth)		2.25" (4 teeth)		2.50" (5/6 teeth)		3.00" (5/6/7 teeth)		4.00" (6/7 teeth)		5.00" (7/8 teeth)		6.00" (8/9 teeth)	
		MAX D.O.C.													
		0.160"		0.200"		0.200" / 0.160"		.240"/.200/.160"		0.240" / 0.200"		0.240" / 0.200"		0.240" / 0.200"	
		N	F	N	F	N	F	N	F	N	F	N	F	N	F
		r.p.m	inch/min	r.p.m	inch/min	r.p.m	inch/min	r.p.m	inch/min	r.p.m	inch/min	r.p.m	inch/min	r.p.m	inch/min
Low Carbon steels (125-180 HB)	TL20 - TL40	1.400	50/65/85	1.280	60	1.090	63/78	900	57/64/72	720	70/77	570	48/53	450	57/63
Carbon steels (170-220 HB)	TL20 - TL40	1.250	45/60/75	1.150	55	950	55/67	750	48/53/80	610	60/67	500	43/47	400	50/55
Alloyed steels (200-260 HB)	TL20 - TL40	900	35/45/55	820	40	670	40/47	500	30/35/42	400	43/47	350	30/33	280	35/40
Tool & Die steels (30-40 HRC)	TL20 - TL40	750	27/35/45	680	32	580	35/42	450	27/32/37	350	35/41	300	25/28	200	30/35
Stainless steels (150-270 HB)	TL20 - TL40	1.050	40/50/82	950	45	820	47/57	550	40/48/53	520	51/57	400	32/35	320	43/47
Gray Cast Iron (200-250 HB)	TL20 - TL40	1.080	50/68/85	980	62	850	50/80	700	55/66/77	560	72/80	450	50/55	360	45/50
Nodular Cast Iron (180-250 HB)	TL20 - TL40	900	43/57/70	820	52	700	42/67	600	48/57/66	460	60/67	370	40/45	300	40/45

Reduced cutting data for cutting pattern

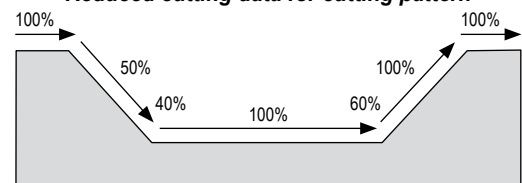

Note: Feed rate should be reduced when cutting the above pattern.



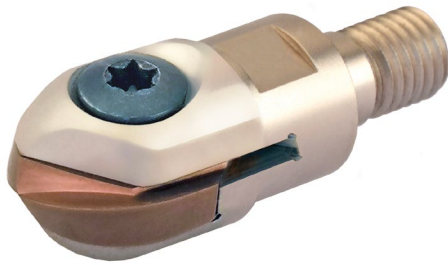

Characteristics:
 Indexable ball nose semi-finishing and finishing cutter equipped with a positive insert that provides low cutting forces and reduced vibration.
 It works well on steels, hardened steels, stainless steels and casts.

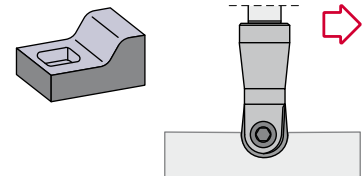
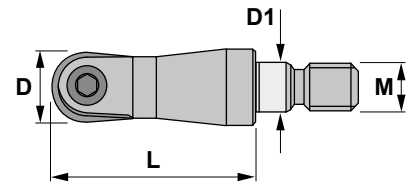

87_06

Reference		D	L	M	D1	Insert size	
8750060062	2	0.625	1.300	M8	0.335	HIB..0625	0.095
8760060075	2	0.750	1.600	M10	0.413	HIB..0750	0.160
8780060100	2	1.000	1.900	M12	0.492	HIB..1000	0.245
8790060125	2	1.250	2.300	M16	0.669	HIB..1250	0.540

WARNING!! Modular Extensions (Pages F07 to F13).

Reference		Nm
8750060062	1627	4.0
8760060075	1637	4.0
8780060100	1647	7.0
8790060125	1687	7.0





Characteristics:
Indexable ball nose semi-finishing and finishing cutter equipped with a positive insert that provides low cutting forces and reduced vibration.
It works well on steels, hardened steels, stainless steels and casts.

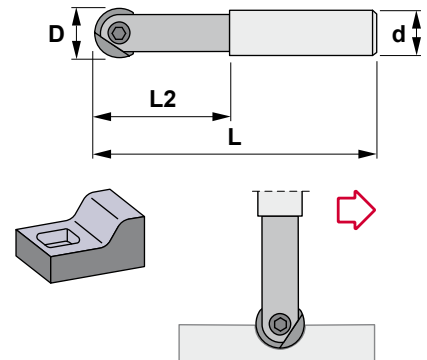

87_00

Reference		D	D2	L	L2	Insert size		Nm	
8730000037	2	0.375	0.375	4.00	1.250	HIB..0375	1607	3.0	0.220
8740000050	2	0.500	0.500	4.00	1.250	HIB..0500	1617	4.0	0.530
8750000062	2	0.625	0.625	5.00	1.250	HIB..0625	1627	4.0	0.575
8760000075	2	0.750	0.750	6.00	1.250	HIB..0750	1637	4.0	1.100
8780000100	2	1.000	1.000	6.00	1.250	HIB..1000	1647	7.0	1.655
8790000125	2	1.250	1.250	6.00	1.250	HIB..1250	1687	7.0	3.420



Characteristics:
Indexable ball nose semi-finishing and finishing cutter equipped with a positive insert that provides low cutting forces and reduced vibration.
It works well on steels, hardened steels, stainless steels and casts.

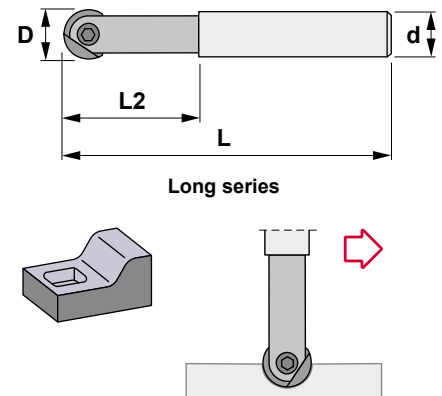

87_01

Reference		D	D2	L	L2	Insert size		Nm	
8730010037	2	0.375	0.375	6.00	2.000	HIB..0375	1607	3.0	0.440
8740010050	2	0.500	0.500	6.00	2.000	HIB..0500	1617	4.0	0.660
8750010062	2	0.625	0.625	8.00	2.000	HIB..0625	1627	4.0	0.880
8760010075	2	0.750	0.750	8.00	2.000	HIB..0750	1637	4.0	1.475
8780010100	2	1.000	1.000	10.00	2.000	HIB..1000	1647	7.0	2.535
8790010125	2	1.250	1.250	10.00	2.000	HIB..1250	1687	7.0	3.420

HIB..

Round positive inserts with 11° clearance. G08

Reference	d
HIB..0375	0.375
HIB..0500	0.500
HIB..0625	0.625
HIB..0750	0.750
HIB..1000	1.000
HIB..1250	1.250

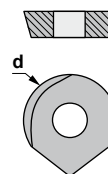

HIBF

HIBS



Recommended cutting conditions (End Mill & Modular Head Style)

Material	Operation	Insert Grade	TOOL DIAMETER					
			0.375"		0.500"		0.625"	
			No. of flutes					
			2		2		2	
		General	High Feed	General	High Feed	General	High Feed	
Carbon Steel Alloy Steel (<30 HRC)	N(rpm)	TL10 - TL20	6360	9550	5300	7960	3180	4770
	Vc(sfm)		656	984	656	984	656	984
	Vf(in/min)		100	301	83	250	63	188
	fz(in/t)		0.008	0.016	0.008	0.016	0.010	0.020
	doc(in)		0.010	0.006	0.012	0.008	0.031	0.016
	woc(in)		0.039	0.031	0.047	0.035	0.063	0.043
Tool Steel Alloy Steel (30-40 HRC)	N(rpm)	TL10 - TL20	5730	7960	4770	6630	2860	3980
	Vc(sfm)		591	820	591	820	591	820
	Vf(in/min)		90	250	75	209	56	157
	fz(in/t)		0.008	0.016	0.008	0.016	0.010	0.020
	doc(in)		0.010	0.006	0.012	0.008	0.031	0.016
	woc(in)		0.039	0.031	0.047	0.035	0.063	0.043
Tool Steel Pre-hardened (40-50 HRC)	N(rpm)	TL10 - TL20	4770	6360	3980	5300	2380	3180
	Vc(sfm)		492	656	492	656	492	656
	Vf(in/min)		56	125	47	104	28	63
	fz(in/t)		0.006	0.010	0.006	0.010	0.006	0.010
	doc(in)		0.010	0.006	0.012	0.008	0.031	0.016
	woc(in)		0.039	0.031	0.047	0.035	0.063	0.043
Tool Steel (55-65 HRC)	N(rpm)	TL10 - TL20	5730	7960	4770	6630	2860	3980
	Vc(sfm)		591	820	591	820	591	820
	Vf(in/min)		90	188	75	156	45	94
	fz(in/t)		0.008	0.012	0.008	0.012	0.008	0.012
	doc(in)		0.004	0.004	0.005	0.005	0.006	0.006
	woc(in)		0.008	0.008	0.010	0.010	0.013	0.013
Cast Iron	N(rpm)	TL10 - TL20	6360	9550	5300	7960	3180	4770
	Vc(sfm)		656	984	656	984	656	984
	Vf(in/min)		150	376	125	376	87	225
	fz(in/t)		0.012	0.020	0.012	0.024	0.014	0.024
	doc(in)		0.010	0.006	0.012	0.008	0.031	0.016
	woc(in)		0.039	0.031	0.047	0.035	0.063	0.043

Recommended cutting conditions (End Mill & Modular Head Style)

Material	Operation	Insert Grade	TOOL DIAMETER					
			0.750"		1.000"		1.250"	
			No. of flutes					
			2		2		2	
		General	High Feed	General	High Feed	General	High Feed	
Carbon Steel Alloy Steel (<30 HRC)	N(rpm)	TL10 - TL20	3180	4770	2540	3830	1590	2090
	Vc(sfm)		656	984	656	984	524	688
	Vf(in/min)		63	188	50	151	31	82
	fz(in/t)		0.010	0.020	0.010	0.020	0.009	0.019
	doc(in)		0.039	0.020	0.049	0.024	0.062	0.043
	woc(in)		0.079	0.059	0.098	0.071	0.125	0.094
Tool Steel Alloy Steel (30-40 HRC)	N(rpm)	TL10 - TL20	2860	3980	2290	3180	1190	1590
	Vc(sfm)		591	820	591	820	393	524
	Vf(in/min)		56	157	45	125	23	62
	fz(in/t)		0.010	0.020	0.010	0.020	0.009	0.019
	doc(in)		0.039	0.020	0.049	0.024	0.062	0.043
	woc(in)		0.079	0.059	0.098	0.071	0.125	0.094
Tool Steel Pre-hardened (40-50 HRC)	N(rpm)	TL10 - TL20	2380	3180	1910	2540	1000	1490
	Vc(sfm)		492	656	492	656	328	492
	Vf(in/min)		28	63	22	50	9	28
	fz(in/t)		0.006	0.010	0.006	0.010	0.004	0.009
	doc(in)		0.039	0.020	0.049	0.024	0.062	0.043
	woc(in)		0.079	0.059	0.098	0.071	0.125	0.094
Tool Steel (55-65 HRC)	N(rpm)	TL10 - TL20	2860	3980	2290	3180	800	1190
	Vc(sfm)		591	820	591	820	262	393
	Vf(in/min)		45	94	36	75	7	22
	fz(in/t)		0.008	0.012	0.008	0.012	0.004	0.009
	doc(in)		0.008	0.008	0.010	0.010	0.062	0.043
	woc(in)		0.016	0.016	0.020	0.020	0.125	0.094
Cast Iron	N(rpm)	TL10 - TL20	3180	4770	2540	3820	1590	2090
	Vc(sfm)		656	984	656	984	524	688
	Vf(in/min)		87	225	70	180	43	115
	fz(in/t)		0.014	0.024	0.014	0.024	0.013	0.027
	doc(in)		0.039	0.020	0.049	0.024	0.062	0.043
	woc(in)		0.079	0.059	0.098	0.071	0.125	0.094





Characteristics:
 General application end mill for slot milling, peripheral milling, ramp milling and drilling, pocket milling and copy milling.
 Recommended for the machining of aluminium, plastics and exotic materials.

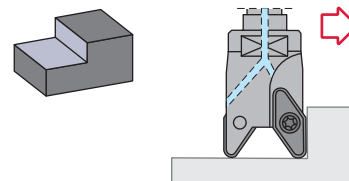
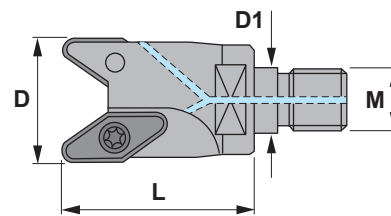

034406

Reference		D	L	M	d	D1	Insert size			Nm	
0344060062	2	0.625	1.378	M8	0.551	0.335	VCGT22..	1225	5507	0.9	0.088
0344060075	2	0.750	1.378	M10	0.708	0.413	VCGT22..	1225	5507	0.9	0.154
0344060100	2	1.000	1.968	M12	0.827	0.492	VCGT33..	1341	5515	3.0	0.242
0344060125	2	1.250	1.968	M16	1.142	0.669	VCGT2205..	1250	5520	4.0	0.528

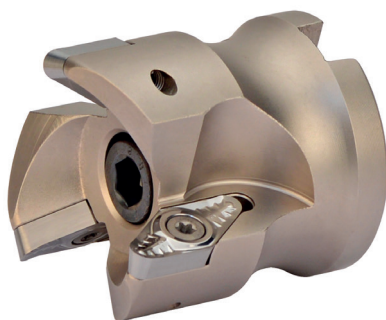

Characteristics:
 General application bottom cutter for slot milling, peripheral milling, ramp milling and drilling, pocket milling and copy milling.
 Recommended for the machining of aluminium, plastics and exotic materials.

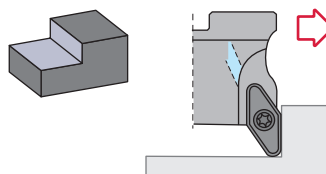
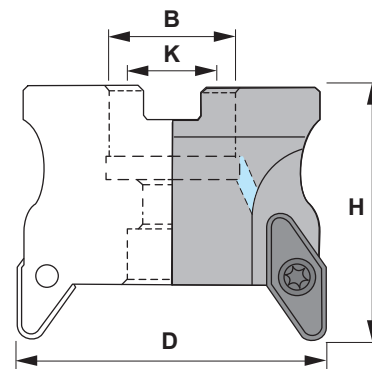

034490

Reference		D	H	K	B	Insert size				Nm	
0344900150	3	1.500	2.000	0.25	0.500	VCGT2205..	1250	5520	UNF.14	0.9	0.396
0344900200	3	2.000	2.000	5/16	0.750	VCGT2205..	1250	5520	UNF.38	0.9	0.770
0344900250	4	2.500	2.125	3/8	1.000	VCGT2205..	1250	5520	UNF.12	3.0	1.760
0344900300	5	3.000	2.125	3/8	1.000	VCGT2205..	1250	5520	UNF.12	4.0	2.530

VCGT

35° rhombic positive inserts with 7° clearance. G14

Reference	l	T	d	r
VCGT221..	0.437	0.125	0.250	0.016
VCGT222..	0.437	0.125	0.250	0.031
VCGT331..	0.650	0.187	0.375	0.016
VCGT332..	0.650	0.187	0.375	0.031
VCGT333..	0.650	0.187	0.375	0.047
VCGT2205..	0.870	0.219	0.500	0.118

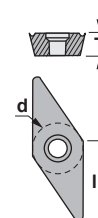

VCGT-AL



VCGT-AP



Recommended cutting conditions

Material		Cutting speed	
		ZR 10 Vc (inch/min)	KM 15 Vc (inch/min)
Aluminium alloys	Rm < 280 N/mm ²	59.055	39.370
	Rm < 280 N/mm ²	39.370	31.496
Copper alloys	Long chipping	11.811	9.842
Thermoplastics			11.811
Aluminium alloys	Si < 12 %	3.937	31.496
	Si < 12 %	7.874	
Copper alloys	Short chipping	19.685	15.748
Magnesium alloys			15.748
Duroplastics		7.874	5.905

Maximum feed per tooth fz (inch/z) in inches

VCGT33..	VCGT2205..
0.013	0.019
0.011	0.015

Recommendations for further applications

Pocket milling and axial plunging

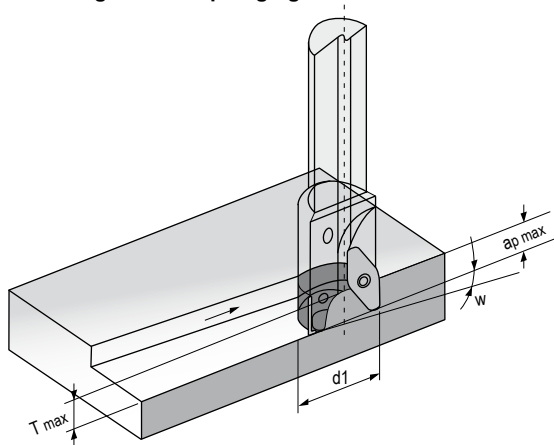

Circular milling

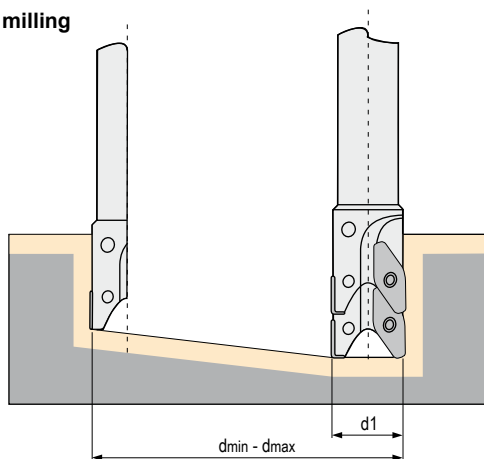

Helix angle W1 max and internal depth of cut Tmax

	VCGT 33...-ALM	VCGT 220530-ALM
ap max	0.531	0.590
T max	0.314	0.354
W1 max degree		
0.625		
0.750		
1.000	0.944	
1.250		0.866
1.500		0.590
2.000		0.472
2.500		0.354
3.000		0.275

d1 inch	dmin inch	dmax inch
0.625	0.625	0.625
0.750	0.750	0.750
1.000	1.000	1.000
1.250	1.250	1.250
1.500	1.500	1.500
2.000	2.000	2.000
2.500	2.500	2.500
3.000	3.000	3.000



